

CRASH

MICRO GAMES ACTION

No.7 August 1984 75p



FULL THROTTLE (MICROMEGA)
& **RAPSCALLION** (BUG-BYTE)
—reviewed

SUMMER COMPETITION SPECIAL

8 ACE COMPETITIONS & 100s OF PRIZES!!

OVER £3,000 IN VALUE FROM:

**Lothlorien * Melbourne House
Micromega * Poppy Soft * R&R
Realtime * Ultimate * Crash**

SPECTRUM
MONTHLY SPECTRUM SOFTWARE REVIEW
**ATIC ATAC MAP
PART 2**

Trade Enquiries:
 Microdealer
 0727 34351

Prism
 01-253 2277

Wynd up
 061-872 5020

Ferranti + Craig
 0722 33022

Pinnacle
 0689 73141

Centresoft
 021-520 7591

Lightning
 01-969 8344

Leisuresoft
 0604 46658

P.C.S.
 0254 691211

R + R
 0226 710414

Drake
 0752 672235

Twang
 0734 508608

FULL THROTTLE



You could be at Silverstone, Nurburgring, San Marino ... or any of ten circuits in the world. You are at the back of the field of forty riders. The start is seconds away the flag drops! Can you fight to the front ... and stay there?



3D Motor Bike
 Grand Prix
 on the
 48K Spectrum — £6.95



Compatible with Kempston, Protek/AGF,
 and Interface 2 joystick types.

Available through good
 computer stores
 everywhere.



CRASH

MICRO GAMES ACTION

ISSUE 7 AUGUST 1984

Contents

Editor
Roger Kean

Consultant Editor
Franco Frey

Production Designer
David Western

Art Editor
Oliver Frey

Adventure Editor
Derek Brewster

Staff Writer
Lloyd Mangram

Contributing writers
Matthew Uffindell
Chris Passey

Client Liaison
John Edwards

Subscription Manager
Denise Roberts

Telephone numbers
General office 0584 5620
Editorial/studio 0584 5851
Advertising 0584 5851

Hot Line 0584 3015

Crash Micro is published monthly by **Newsfield Ltd.**,
1/2 King Street, Ludlow,
Shropshire.

General correspondence to:
PO Box 10, Ludlow,
Shropshire SY8 1DB

© 1984 Newsfield Limited

No material may be reproduced in whole or in part without written consent of the copyright holders.

Photosetting by SIOS,
111 Salisbury Road,
London NW6

Colour origination by Scan Studios, 44 Wallace Road, London N1

Printed in England by Carlisle Web Offset (Member of the BPCC Group), Newtown Trading Estate, Carlisle.

Distribution by COMAG,
Tavistock Road, West Drayton, Middlesex UB7 7QE

Subscriptions: 12 issues
£9.00 UK Mainland (post free)
Europe: 12 issues £15 (post free)

We cannot undertake to return any written or photographic material sent to CRASH MICRO unless accompanied by a stamped addressed envelope.

Cover by Oliver Frey

Features

Articles

Regulars

D.G.Y

| | |
|-----|--|
| 54 | ACG KEY WINNER So who won the key to Atic Atac? |
| 56 | ATIC ATAC – THE MAP! Part 2 of our pull-out poster |
| 101 | LO PROFILE A look at a professional keyboard |
| 98 | CRASHBACK Games and reviews – do they stand re-examination? |
| 4 | EDITORIAL And indexes |
| 26 | CRASH FORUM Can Lloyd keep his head above the pile...? |
| 36 | NEWS INPUT A brief round-up for the month – Imagine collapse |
| 69 | ADVENTURE TRAIL Derek goes Beyond and into the Land of Midnight – Adventure tips |
| 76 | JETMAN The continuing misadventures |
| 78 | CRASH HOTLINES Top 50 fave games and the Adventure Chart |
| 80 | PLAYING TIPS Incorporating Lloyd Mangram's Hall of Slime |
| 103 | TERMINAL MAN Cross makes a bargain |
| 18 | SABRE WULF MAP A chance to win the only Amulet of ACG |
| 20 | MUGSY – FAKE EXPERT Win the Melbourne House computer comic |
| 31 | LOTHLORIEN COMPETITION Brill prizes for all! |
| 42 | CDS POOL COMPETITION The one that didn't work, so here it is again! |
| 60 | FULL THROTTLE An exclusive for CRASH readers – win the latest 3D game from Micromega |
| 63 | TITANIC COMPETITION Can you find the famous liner and win the game? |
| 83 | CRASH QUIZ The one that really works... |
| 84 | TANK DUEL Pit your wits in the 3D desert and win the game from Realtime |

NEXT ISSUE ON SALE AUGUST 30th



CRASH

MICRO GAMES ACTION



SUMMER SLIPS

There were moments at the Trade Day of the Earls Court Computer Fair in June, when the fair seemed like a symbol for the month. The stand that should have been occupied by **Carnell Software** had been handed over to someone else. Carnell's name plate had vanished to be replaced by that of the new occupiers. But even as I stood watching them fill the stand, their name plate was replaced by another and they were out! One exhibitor was heard to murmur, 'It's like the Wall Street Crash round here! The show's not even officially open yet and software companies are going out of business like flies!'

Well it was a bit of an exaggeration, but what with **Carnell** collapsing at the start of the month, **Salamander** half way through, and the earthquake from Liverpool as **Imagine** crashed, one could be forgiven for thinking that the bubble had burst. But has it?

Another rumble was to be heard at the very start of June, with the news that **Argus** had bought out **Quicksilva**. The main difference being that the shareholders and management of Quicksilva seemed pretty happy by the take over, which, according to **Rod Cousens**, had been on and off and on again for months. Quicksilva's take over indicates something Rod Cousens has been heard to state would happen, a slow merging of interests between the several bigger games software houses to create a much more powerful base for marketing

and development. Of all the events of June, however, nothing was quite so spectacular as the demise of **Imagine**.

Perhaps the major problem associated with the collapse of **Imagine** is that like a large ocean liner going down, it may suck a lot of others with it – not in the sense that anyone else is financially dependent on **Imagine**, but in the sense that the loss of the powerful company may be seen by the world at large as the end of the British games software boom. If this assumption is made by the media, then it will be an inaccurate and unfair one. The computer press, of course, has a fair idea of the shenanigans that have been going on behind the scenes at **Imagine House** recently, but the **National Newspapers** (who have so loved reprinting **Imagine**'s outrageous stories of 17 year old programmers earning salaries of £35,000 plus a year) don't know, and probably don't care much. Neither will the TV companies who have flocked to Liverpool to shoot film and video of the brash, young new moguls of the software boom; nor will the gloomy pink predictions of the *Financial*

Times make better reading, for they have never been able to distinguish between the clumsy fumbings of the American software scene with its spectacular upsets over

dedicated arcade machines and home VCS games machines, and the far more thoroughbred, quirky and innovative British home computer games scene.

So there is a distinct danger that the aftermath of **Imagine**'s financial collapse will be read as the **END – FINITO** – no more games software – another skateboard fad – a bubble burst. Fortunately most of us who care about the future of the home computer and more especially the rich and exciting development possibilities of the computer game, know that this is a load of bullshit. So perhaps the world will get lucky and the media at large will totally ignore **Imagine**'s disaster. Or better still, perhaps they will examine it all properly and come to the conclusion that as an organisation **Imagine** was heading for a fall of its own making, due to mismanagement at the very top.

What is truly sad about the whole sorry business is that a lot of people employed by the software giant in Liverpool are now jobless and a lot of magazines are out of ad revenue they should have received; worse still, perhaps, for the tape duplicators who have helped create the wealth of the three directors of **Imagine** who seem to have pulled off one of the biggest financial coups for a long while, getting out with assets and money to leave the rest to rot.



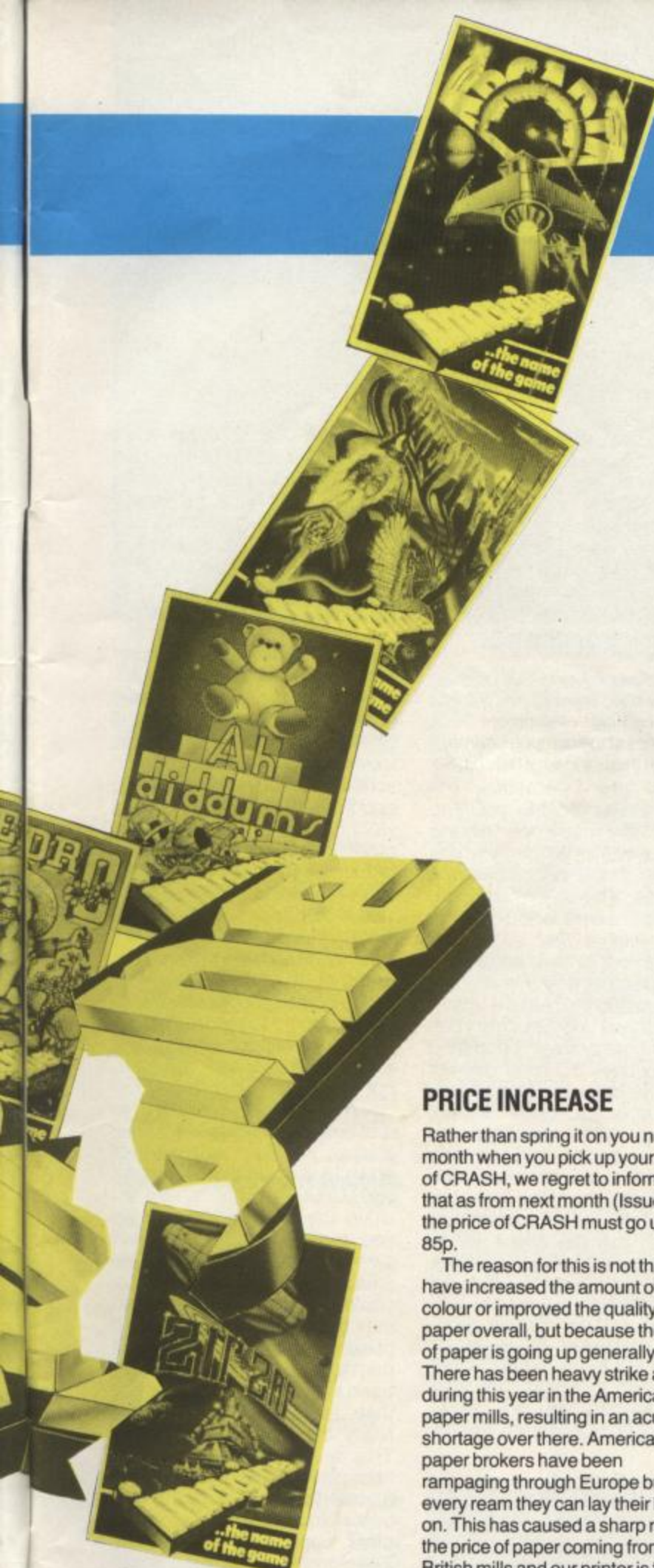

HOW THE RATINGS WORK

There seems to have been some confusion among readers and software houses about ratings – not so much about the way they work, but more over what the OVERALL percentage represents in value. When CRASH started, we said that we would not be crunching all reviewed games into the high percentage bracket. The idea was to give some latitude to distinguish between programs ratings.

Once again, we repeat what the percentages mean, BUT STRESS THAT THE WRITTEN REVIEWS AND OPINIONS ARE FAR MORE IMPORTANT THAN THE

OVERALL PERCENTAGE which is an average of the other six ratings.

| | |
|-----------|---|
| Under 30% | a waste of time |
| 31-40% | generally poor but may appeal to some average |
| 41-50% | reasonable average |
| 51-55% | if game type enjoyed |
| 56-60% | good on most counts |
| 61-70% | generally recommended |
| 71-80% | highly recommended |
| 81-90% | Knight of the British Empire |
| Above 90% | Words fail . . . |

INDEX TO GAMES REVIEWED IN THIS ISSUE

| | |
|--|--|
| AUF WIEDERSEHEN PET Tynesoft 39 | LORDS OF MIDNIGHT Beyond 72 |
| AUTOMANIA Mikrogen 7 | MESSAGE FROM ANDROMEDA Interceptor Micros 69 |
| BEAKY & THE EGG SNATCHERS Fantasy 90 | MR WONG'S LOOPY LAUNDRY Artic 12 |
| BOSSMAN Avalon 52 | NEW VENTURE Falcon 53 |
| BURIABEAST Kerian 37 | OMADAN ATTACK Avalon 40 |
| CAVELON Ocean 90 | PIT-STOP Avalon 46 |
| CLERKY Unique 36 | RAPSCALLION Bug-Byte 93 |
| COLDITZ Phipps Associates 74 | REALM OF THE UNDEAD Lothlorien 11 |
| CRICKET T.J. Owen 13 | SAND SCORCHERS Unique 86 |
| DARTZ Automata 51 | SPECTREALM Rune Soft 44 |
| DEATH CHESS 5000 Artic 38 | STAR TRADER Bug-Byte 36 |
| DOTTY Dollar Soft 91 | TLL Vortex 14 |
| ESCAPE FROM PULSAR 7 Digital Fantasia 70 | 3D TANK DUEL Realtime 88 |
| FULL THROTTLE Micromega 6 | UGH! Softek 14 |
| GATECRASHER Quicksilva 86 | UNITED C.C.S. 45 |
| HAMPTONS CAUGHT B. Sides Software 12 | WAR OF THE WORLDS C.R.L. 44 |
| HOWZAT Wyvern Software 13 | WHIZZ KID Unique 38 |
| HYPERBLASTER Lothlorien 51 | WORLD CUP FOOTBALL Artic 87 |
| JACK & THE BEANSTALK Thor 92 | |
| KOSMIC KANGA Micromania 47 | |

PRICE INCREASE

Rather than spring it on you next month when you pick up your copy of CRASH, we regret to inform you that as from next month (Issue 8) the price of CRASH must go up to 85p.

The reason for this is not that we have increased the amount of colour or improved the quality of the paper overall, but because the price of paper is going up generally. There has been heavy strike activity during this year in the American paper mills, resulting in an acute shortage over there. American paper brokers have been rampaging through Europe buying every ream they can lay their hands on. This has caused a sharp rise in the price of paper coming from British mills and our printer is forced to pass on this increase to us.

We deeply regret the necessity for this increase, and hope that you will go along with us. At 85p, and with its high editorial content, we still feel CRASH represents good value for your money. Of course, those readers who have take out subscriptions will still continue to receive their copies at the old price of 75p. Anyone who would like to subscribe to CRASH – this is the last issue with the coupon at an effective price of 75p per copy. Better take advantage!

What is certain, is that Imagine's demise will not affect the rest of the software industry one iota. Indeed, it may well benefit some software houses. It's a pity Imagine will miss the coming pre-Christmas season which promises to be rich in the mixture of dross and brilliance that makes British software such an exciting thing to write about.

There are more details about the Imagine crash on page 32.

INDEX TO ADVERTISERS

| | |
|----------------------------|----------------------|
| Addictive Games 22 | Incentive 35 |
| AGF 24 | Lothlorien 10 |
| Arcade Software 107 | Micromania 41 |
| Beyond Software 22,23 | Micromega 2 |
| Cambridge Computing 48 | Mikrogen 8 |
| CDS Microsystems 49 | New Generation 43 |
| Cheetah Soft 50 | Peaksoft 39 |
| Crash Mail Order 63 | Poppy Soft 97 |
| Crash T-shirts/binders 95 | P.S.S. 71 |
| C.R.L. 16,17 | Quicksilva back page |
| Cross 29 | Realtime 77 |
| DK'Tronics 108,109,110,111 | Runesoft 22 |
| Dream Software 42 | Silversoft 96 |
| Fantasy 58 | Ultimate 9 |
| Frel 59 | Vortex 25 |
| Gargoyle Games 30 | Walker 29 |
| Gilsoft 68 | ZX Microfair 62 |

Full Throttle

Producer: **Micromega**
Memory required: **48K**
Retail price: **£6.95**
Language: **machine code**
Author: **Mervyn Estcourt**

A new game from **Micromega** has become something to look forward to since *Deathchase* and *Code Name Mat*. Each one seems to be carefully crafted for a specific purpose from this software house that releases relatively few games. *Full Throttle* is the latest program from **Mervyn Estcourt** (*Luna Crabs*, *Deathchase*) and continues his theme of bikes, this time on the race track. Interestingly enough, Mervyn had never ridden a bike before work on this game. Towards the end, he felt he ought to get some experience, borrowed a friend's and rode off into the sunset, or something, leaving Micromega worried for his safety. As you can now see, he was okay!

Full Throttle is to bikes what Psion's *Chequered Flag* was to racing cars BUT with the addition of competition in the form of 39 other riders on the track. Unlike *Deathchase* where you only saw the handlebars of your machine, in *Full Throttle* your biker and machine are in full view ahead of you on the track. Maximum speed is 175mph and you can race on any of ten of the world's top circuits with your 500cc motorcycle. The circuits provided are Donnington (UK), Mugello (San Marino), Jarama (Spain), Paul Ricard (France), Nurburgring (W. Germany), Misano (Italy), Silverstone (UK), Spa-Francorchamps (Belgium), Rijeka (Yugoslavia) and Anderstorp (Sweden). Information is provided on recent circuit records, average speeds and the winning rider's name.

The display screen is elegantly simply in layout with circuit name, speed, position and lap number superimposed over the landscape. This consists of the grass, moving background and the track itself, black with white centre lines and cross-hatched shaded edges. Circuits are selected via a full display map of each using SPACE to select and ENTER to return to the main menu. The number of



Roaring up from behind at Full Throttle

laps to be raced may be selected between one and five. It is possible to practice without other riders on any circuit.

Full Throttle is also unique in that it is a serious racing game because there are no spectacular explosions should you crash. Leaving the track results in your slowing down – running into other riders will result in almost total loss of speed as a penalty.

CRITICISM

● 'Have you ever seen Atari's *Pole Position* racing car game – yes? Well here is *Full Throttle* and it's a very similar form of game but on bikes. What's more – it's superb! The 3D is some of the best (if not the very best) I have seen. The game itself is fun to play and is exhilarating (I bet you can remember swaying on your seats playing *Deathchase*! This one will prove just as exciting). I found it extremely addictive partly due to the fact that the other riders are obviously of world class standard, and it will certainly be a while before I can pop any champagne corks! But I bet Micromega will be! With ten circuits to choose from, if (and when) you become champ at one, the rest will still prove very hard to conquer due to the fact that they each have their own characteristics, fast, lots of bends, even hairpins. Gotta be a Crash Smash!

● 'Atari will have to pull up their socks if they want to out throttle Full Throttle! Perhaps *Pole Position* will have more colour though. The 3D graphics in Full Throttle are marvellous, the most realistic looking yet. The effect of the road going into the distance works brilliantly – you can see double bends before it vanishes. The other riders are all green, same colour as the grass, and a first slight disappointment turns to admiration as you realise why this simplicity – it adds to the realism. Also it avoids those ugly Spectrum colour attribute problems that tend to so bedevil 3D road games. The physical behaviour of your machine is also quite realistic, skidding with speeding too much on bends, very controllable with use of brake and accelerator, just like the real McCoy. A neat control key touch is that the brake will always override the accelerator, so you never have to take your finger off the accelerator key. I'm convinced this is going to be a big hit both for people playing alone and for group get togethers, especially as best times and positions can be calculated. Great!

● 'First impressions of this game were that it was outstanding – a *Pole Position* like game where the road disappeared into the horizon and scrolled exceptionally well. On playing for a bit, I noticed it was even

better, because the road does more than it does in *Pole Position* – it actually moves left and right across the screen instead of staying fixed (nearest the viewer) in the centre of the screen. Waiting on the starting grid I was startled when the flag went up and I couldn't see the other 39 bikers for dust. Are my reactions so slow? The handling of the bike is very realistic. When you take a left hand corner, because of the G-force, the bike automatically moves over to the right, and the faster you take a corner, the more the rider leans over. Hardly any details have been left out, for instance, if you move over onto the grass, not only does the bike slow down but it actually bumps up and down as well. If you come to a stop, the rider puts his foot down to support the bike, and if you wait for a while, or are too slow, the other riders will lap you, roaring by either side, and swerving to pass you. One small niggle; perhaps the colour could have been better used on the background hills, just to break them up a bit, and perhaps my bike could have been a bit more definite a colour than yellow – but these are really minor and trivial points. This is an entirely new breakthrough in 3D road racing type games for the Spectrum, and one which will make games for other computers blush – the Spectrum's done it again! Whatever has been said about 3D games before – this is a

Waiting to be lapped



a.u.t.o.m.a.n.i.a

game that sets new standards. It's the ultimate programming feat (to date!) – you'll just have to buy it to see it.

COMMENTS

Control keys: good – 1/0 left/right, 9 to accelerate and bottom row to brake; R returns to menu and quits game or practice

Joystick: ZX 2, Kempston, Protek, AGF

Keyboard play: very responsive

Use of colour: not much but it is used very well and avoids worst of attribute problems

Graphics: neat, well drawn bikes, good fast scrolling landscape and some of the best looking 3D yet

Sound: continuous, with starter signal, revving bikes and engine note change, skid sounds

Skill levels: 1, although each track has its own difficulties

Lives: N/A

Originality: not perhaps an original idea, but the development of the 3D certainly is on the Spectrum and this is the first serious bike, road racer

General rating: excellent.

| | |
|---------------------|-----|
| Use of computer | 94% |
| Graphics | 88% |
| Playability | 95% |
| Getting started | 92% |
| Addictive qualities | 85% |
| Value for money | 90% |
| Overall | 91% |

Automania

Producer: Mikrogen

Memory required: 48K

Retail price: £6.95

Language: machine code

Meet a new hero – your average British Worker by the name of Wally Week. Wally Week is destined for big things – like a three percent wage rise next month. Wally works on a car assembly line, in fact he is the assembly line. In this highly original platform type game you must help Wally build a series of cars.

The game has two basic screens, starting off in the stock room. There are three platforms with a single ladder to the first level and two at either end from the second to the third. On the two upper levels are situated the six parts of a car. What you do is walk Wally along the floor,

up the ladders and collect the parts, one at a time and then take them down and through the door to the assembly room. This contains a large hydraulic lift, and on its first level are some of the already assembled bits of a car. When Wally walks his collected stock part over the appropriate area of the vehicle the carried part is automatically deposited in its correct position. Then it's back to the stock room for the next bit. Each piece has a time limit.

Sounds simple enough, even for your average British workman. But then, this is a computer game so nothing is as it looks! The factory is populated with robots and bouncing tyres which kill on contact, and from the overhead gantries in the assembly room, falling air cooling blades cause problems. Fortunately, Wally can jump. To add to his problems the gantries in the stock room keep moving in and out and in difficult positions are various static objects which are designed to tempt an honest man away from his work like teapots (mind the oil cans as well).

When (if) all six parts are correctly assembled, the car is driven off to be replaced by the rudiments of the next one. In all there are ten cars to build starting off with a humble 2CV and ending up with... ah, well that's up to you.

CRITICISM

● 'Automania is a game about Wally – the game itself is far from being a wally game. In fact it's a superb game with excellent graphics and animation. I really enjoyed it. This will be a game of the month I'm sure. I found the choice of the first car very appropriate for Wally – you know, the upturned pram on wheels vegetarian mobile. This



Wally Week and the 2CV

is probably the best game yet from Mikrogen.'

● 'Automania has some of the best animation and realistic graphics that I have ever seen. All the graphics are large and colourful, and needless to say they move smoothly. There is much more to this game than just building a car – it's a race against time – a very fast ticking clock. Colour and sound is well used, with a continuous 'manic' style tune throughout, which may be stopped if it drives you mad. The best game that Mikrogen have ever produced and worth buying.'

● 'Great colour, great sound, amazing graphics. The animation of Wally is just superb. Not only is he a large, highly detailed caricature (rather Andy Capp like) but he is beautifully animated with plenty of neat touches from his flat cap and beer paunch to the cheeky way he turns to look out at you after completing some particularly difficult task well. On top of that comes a game which has been well planned and implemented to provide just the right combination of temptingness with skill difficulties. Timing jumps in two directions over a static obstacle where you must land or take off from a constantly moving platform is very tricky. Automania is highly playable and extremely addictive – don't be put off by what at first appears to be a rather plodding

speed, a bit *Bear Bower*-like, Wally walks faster than some of the obstacles, slower than others and all in all it makes for a properly paced game of high entertainment value.'

COMMENTS

Control keys: preset – Q/A up/down, O/P left/right, M to jump, but all keys may be user-defined

Joystick: ZX 2, Kempston, and almost any other via UDK

Keyboard play: very responsive

Use of colour: very good

Graphics: superb, with excellent animation

Sound: great tune (continuous) with well used sound effects – sound may be switched off

Skill levels: 1

Lives: 3

Screens: 2 but with 10 cars to build in each

Originality: very original use of traditional game components

General rating: very good to excellent, playable and addictive.

| | |
|---------------------|-----|
| Use of computer | 92% |
| Graphics | 89% |
| Playability | 86% |
| Getting started | 83% |
| Addictive qualities | 88% |
| Value for money | 91% |
| Overall | 88% |

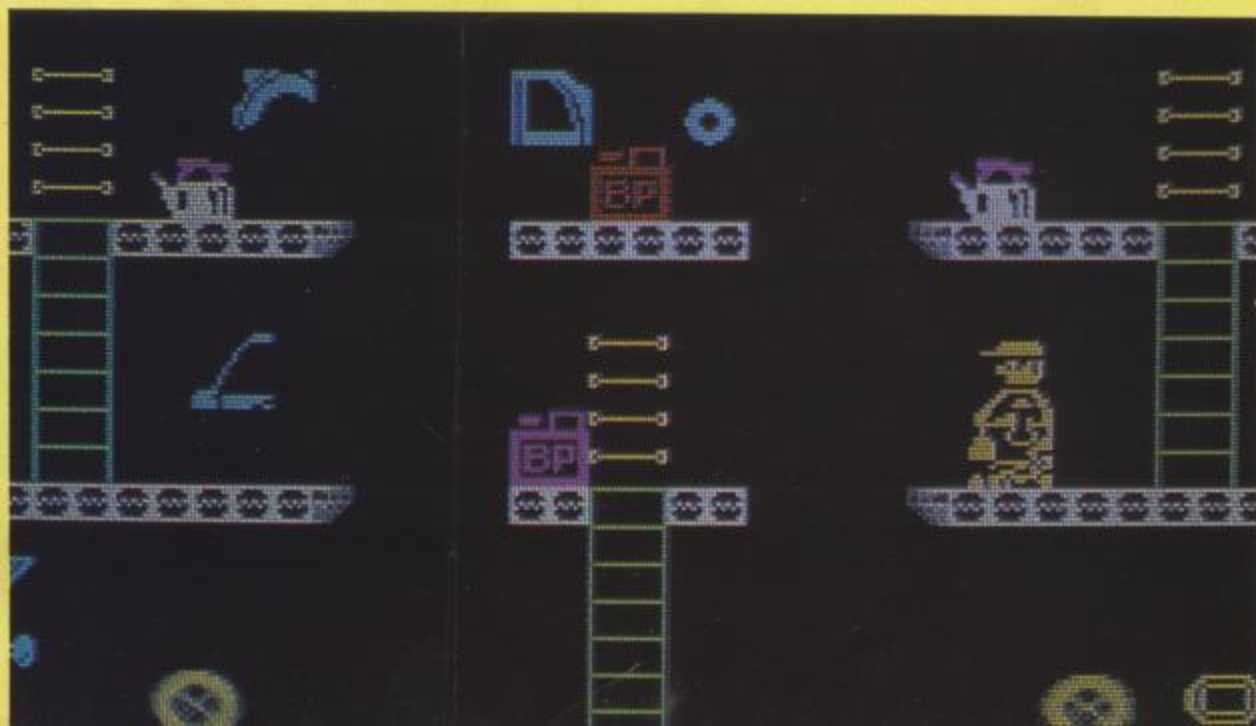

Tel: 0344 427317

AUTOMANIA



WALLY WEEK
is here!

FOR COMMODORE 64 AND 48K SPECTRUM

VEE HAV VAYS TO MAKE YOU ILL



CONFRONTATION: SCENARIOS VOL 1
SPECTRUM £5.95

For use with the Master CONFRONTATION program, this add-on pack gives you four scenarios set in actual 20th Century Conflicts: Afghanistan, Angola, Sinai and Kent following the German Invasion in 1940.

SPECIAL OPERATIONS

SPECTRUM £5.95

"Special Operations has class. If they can do this with a humble Spectrum, what kind of games can we expect for the QL" COMPUTER CHOICE

A graphic adventure. Pick your force to locate, photograph, penetrate and eventually destroy Hitler's secret germ warfare establishment.

JOHNNY REB

DRAGON/TANDY 32K, COMMODORE 64K, MEMOTECH MTX 500/512 £6.95

ALSO FOR SPECTRUM £5.50, ELECTRON/BBC B, ORIC/ATMOS £6.95

"I could quite easily get addicted... very user friendly... good value for money" ELECTRON USER

There's still plenty of fight left in the Confederate South as each side selects forces to do battle on a full graphics battlefield. One or two players.

DIG THIS FOR ATMOS



SPOOKY MANSION

ATMOS/ORIC 48K £6.95

Attacked by bats, nasties and everything that moves, intrepid explorer Hugo First fights his way through the spooky mansion collecting weapons, wakens Dracula and condemns him to a fiery hell. Great effects and sound, good machine-code graphics. 10 levels. 3 Lives. 7 screens.

DIGGER

ATMOS/ORIC 48K £6.95

Monsters in the mineworkings try to stop you taking your gold to the Bank. Clear the screen and they re-emerge with new recruits (up to 60!) and the game speeds up. 4 lives. Great sound and graphics.

CHARLIE'S PICK!

CHOC A BLOC CHARLIE

COMMODORE 64 £6.95
Caught in a time-warp, Charlie is trapped in a sealed warehouse. Avoiding the robots and ferocious guards he builds a time door to escape to the next warehouse. 2 screens, 16 increasingly difficult levels. Sound and smooth machine-code graphics.



HYPERBLASTER

SPECTRUM £5.95

You are commanding a prototype spacecraft on a test flight when you are attacked by an Alien force. Dare you test your Hyperblast and plunge into Hyperspace? Fast action. 100% machine-code. 15 screens. Keyboard manoeuverability.

REALM OF THE UNDEAD

SPECTRUM £5.95
Can you fight off the vampires to reach the subterranean dungeons of Dracula's Castle, where you release the villagers and Dracula, who must be lured to his coffin for the final chill? 3 screens.

Special Offer Look out for the couponed packs - shops and mail order. Buy 3 special offer games (see asterisks). Collect 3 coupons and return to us for a free Lothlorien game of your choice. See pack for details. Offer applies to UK and Eire only. Closing date 30th November 1984.

Please send me (tick box) the following games:

- SPECTRUM 48K**
- Special Operations £5.95
 - * Realm of the Undead £5.95
 - * HyperBlaster £5.95
 - Micromouse (16/48K) £5.95
 - Confrontation - Master Program £7.95
 - * Confrontation - Scenarios Vol 1 £5.95
 - Mummy Mummy £5.95
 - Grid Patrol £5.95
 - Bedlam Blaster (16/48K) £5.95
 - Beetlemania (16/48K) £5.50

Please send me a free colour Catalogue.

* Contains special offer coupon. Others

I enclose a cheque/P.O. made payable to M.C Lothlorien. Please debit my Access A/C No.

Signed _____ Name _____

Address _____

Post Code _____ Key No. C7

Send to: M.C Lothlorien, 56a Park Lane, Poynton, Stockport, Cheshire, SK12 1RE
Tel. Poynton (0625) 876642



LOTHLORIEN
more action for your money

You'll find the full range of Lothlorien ACTIONMASTER, WARMASTER and ADVENTUREMASTER games at leading record shops and good software shops, including:

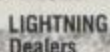
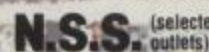
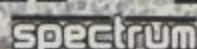

For a complete list of Lothlorien Games send for a FREE colour catalogue. Fill in the coupon today. M.C Lothlorien, 56a Park Lane, Poynton, Stockport, Cheshire, SK12 1RE. Tel: Poynton (0625) 876642

SABRE WOLF

ULTIMATE
PLAY THE GAME

48K SINCLAIR ZX SPECTRUM
£9.95

Realm of the Undead

Producer: **Lothlorien**
 Memory required: **48K**
 Retail price: **£5.95**
 Language: **BASIC and machine code**

Stake 'n chips, 'Fangs for the Memory', and other assorted funnies come to mind as you take a trip into the *Realm of the Undead*. Haunted by tarantulas, bats and the Dark Lord himself, your task is to clear three screens and rescue trapped villagers.

Screen one is a simple maze patrolled by tarantulas, whose bite is death unless you have collected sufficient quantities of garlic cloves. Contact with a member of the undead will result in the loss of a clove of garlic. Once the garlic is harvested it's safe to go and press the lever which is somewhere at the top of the screen. This causes a secret exit to appear, which must be reached before it vanishes again.

Getting onto the second screen, you must free the trapped villagers. This is done by entering a long maze, avoiding the bats and tarantulas, getting to the lever at the bottom and then returning up through the maze to the top level where pressing the lever has opened the castle door. This also releases the villagers which must be 'run over' to rescue them. The castle door only stays open for a short while and closes anyway if you run into a bat. Running into a spider will lose you more garlic. Entering the castle door takes you to the third screen.

Here the Dark Lord will leave his coffin in the centre and chase along with a bunch of zombies. Three bites from Drac and you're dead. A lever beside

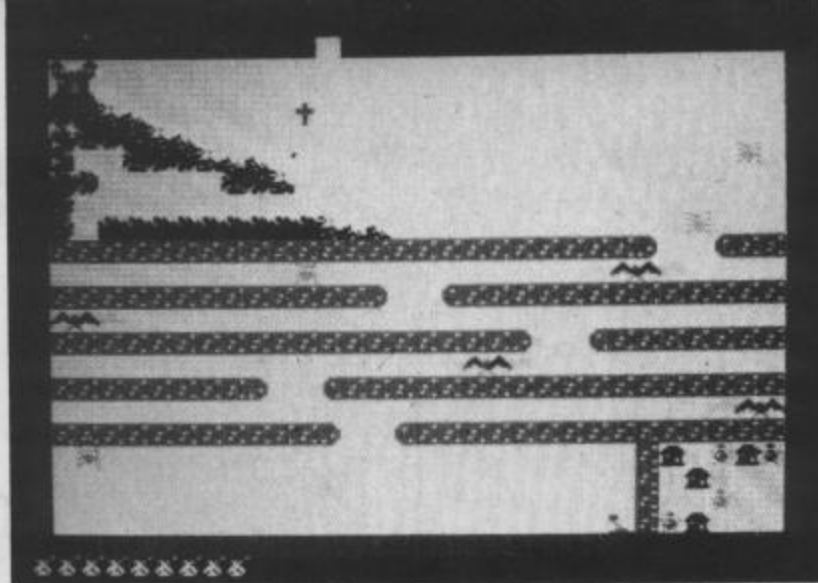

The Castle door's open, but can you reach it in time to rescue the villagers?

the coffin opens the door to a store room at the top right where you can collect a stake. Another lever at the top left causes a hammer to appear for a short while. This too must be collected before either Dracula gets it, or it disappears. Having collected stake and hammer you can entice Drac back into his coffin, shut the lid and drive a stake into his heart. Van Helsing would be proud of you.

CRITICISM

● *'Realm of the Undead* is quite playable considering it is programmed within the realms of Basic. The graphics are neat but could do with a little enlarging, but the biggest problem seems to be that the game is a little bit too simple. Even a mega-dodo like myself completed the game on skill level one, but at the other end of the boot the game is unplayable on skill level five. So this means the addictivity goes down quite a bit. The idea for this game isn't too bad (well not really bad anyway) but graphics and sound could have been enhanced. A nice touch is when you've completed the game and killed Drac, you get warped back out of the castle. My biggest grumbles are with the small graphics, lack of sound and the fact that the instructions don't tell you how to shut Drac's coffin.'

● *'This is a fairly original idea, although the game itself isn't because the concept is played*



Drac's out on patrol and the undead await you...

out in a typical maze with chasers situation. Graphics are small and undetailed and move from a slow jerky pace to such a hyper speed on the higher levels that you can hardly see them! Colours are chosen fairly well although I think a darker background would have been better. I like the way that eating a clove of garlic makes you squeak - exactly the sort of sound I would expect to hear from anyone eating a whole clove of garlic! Yuk! Other than this, you could say there wasn't much sound at all. The game itself is fairly playable, although I wouldn't really recommend it.'

● *'Realm of the Undead* takes you into **Carnell's** realm (except they seem to be very dead) and does it more entertainingly than *The Crypt* or *The Devil Ride In*. With all its drawbacks of small, rather early-Spectrum period graphics, the game manages to be playable and fun. However, I can't imagine it having much lasting appeal for the reason that it is too simple overall, with only the three screens which are quite quickly completed. Some variability is added with the second screen where the maze shapes change from game to game, some being very mean. In the end, a bit lightweight.'

COMMENTS

Control keys: sensible, I/Q up/down, 9/0 left/right and S to drive home a stake
Joystick: none
Keyboard play: very responsive
Use of colour: nicely used
Graphics: small, undetailed and slightly jerky at slower speeds

The cloves of garlic mount up in the first screen maze.

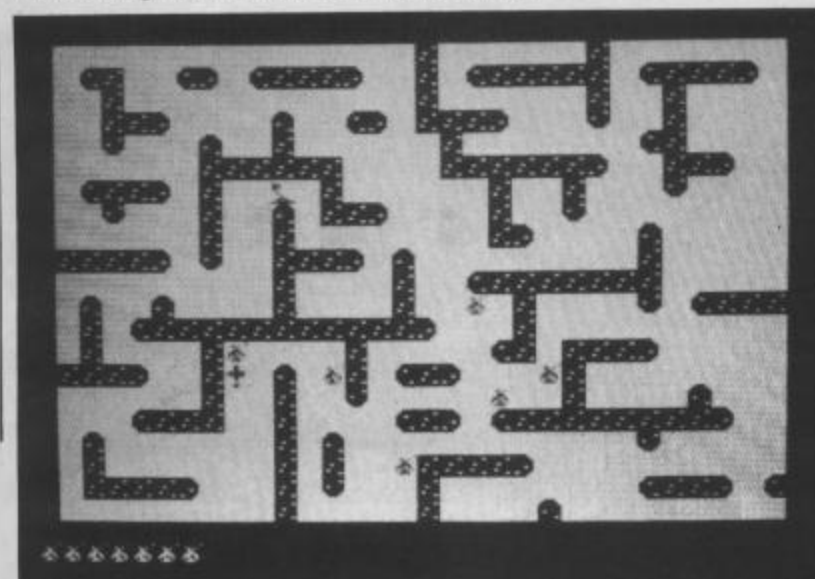

Sound: neat squeaks but little else
Skill levels: 5 speeds
Lives: 3 to start and depends on garlic afterwards
Screens: 3
Originality: concept fairly original, game type quite typical
General rating: fair to average but not much lasting appeal.

| | |
|----------------------------|-----|
| Use of computer | 50% |
| Graphics | 52% |
| Playability | 53% |
| Getting started | 48% |
| Addictive qualities | 45% |
| Value for money | 53% |
| Overall | 50% |



HOW THE RATINGS WORK

| | |
|-----------|--|
| Under 30% | a waste of time |
| 31-40% | generally poor, but may appeal to some |
| 41-50% | average |
| 51-55% | reasonable if type of game enjoyed |
| 56-60% | good on most counts |
| 61-70% | generally recommended |
| 71-80% | highly recommended |
| 81-90% | knight of the British Empire |
| Above 90% | words fail |

Mr Wong's Loopy Laundry

Producer: **Artic Computing**
 Memory required: **16K**
 Retail price: **5.95**
 Language: **machine code**
 Author: **J. Prince**

Computer games do seem to run in cycles – now it's the turn of the Chinese with Ocean's *Chinese Juggler* and Artic's *Loopy Laundry*. Mercifully, considering the verbal possibilities, Artic have contented themselves with a very short scenario on the inlay, merely pointing out that as Mr Wong contends with the laundry, he also chased by soapsuds, an iron and a bag of dirty laundry.

The laundry takes the form of a very traditional looking five-platform game with between two or three ladders connecting each floor. To the right of the screen a laundry chute runs from top floor to the bottom, and it is into this chute on the top floor, that the items of clothing to be found, must be flung. Mr Wong is only able to carry one item at a time (presumably underlining that famous old Chinese proverb about many hands making light work). He is aided in his oriental perambulations by starch, which may be fired at the pursuing laundromaniacs, stiffening their resolve but freezing their action for a few precious moments. The starch, however, runs out very quickly and leaves Mr Wong vulnerable until a new box appears on the screen somewhere. To be active it must be collected before it vanishes again.

On the ground floor there is a washing line stretched out which shows the items of clothing that must be collected. These float around (unmoving) on the different floors. A busy washing machine calculates points remaining, which start at 990 and tick down.

CRITICISM

● 'In many ways this is a 'Panic' like game – running up and down ladders, avoiding aliens (well irons etc.) and generally carrying out your task. The laundry is small compared with Mr Wong, but quite detailed and well coloured. Keyboard

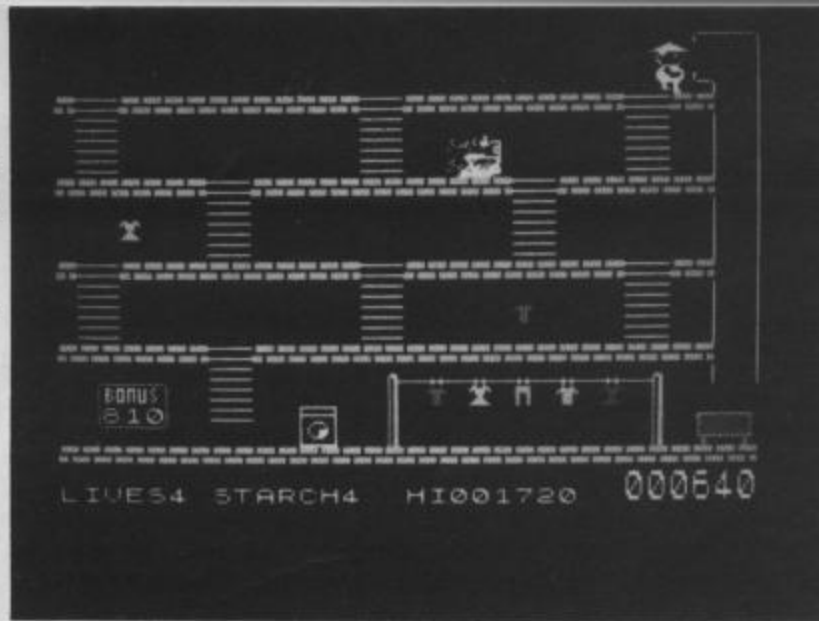

Velly creak wash in Mr Wong's Loopy Laundry, but starch is velly stlong.

responses are good with a sensible key layout. The game is very different but not really addictive. An unoriginal 'Panic' type game with few variations on the original theme.'

● 'The graphics are quite neat and move well although I found it irritating that due to the character block reading it is easy to get 'killed off' by a chaser in certain circumstances when the eye tells you you have escaped. This happens most on the ladders where on reaching the top and moving off along the floor, the ascending chaser's block touches yours. The sound is a bit sparse apart from the nice Chinese type tune.'

● 'This is a 'Panic' variation game. It's generally good, ie. graphics, colour and playability are all okay, but it's only a variant and doesn't tend to be too original. Artic's *Bear Bover* was a very good platform game – this is not so hot! Basically it is playable and almost addictive but tends to suffer from averageness (if there isn't such a word, there is now!).'

Hamptons Caught

Producer: **B. Sides Software**
 Memory required: **48K**
 Retail price: **£5.50**
 Language: **machine code**

As you might well guess from the punning title, *Hamptons Caught* is a maze game – a rather large one. Your job is to guide poor old Hampton out of the maze in which he's been caught. Hampton is short-sighted and something of an explorer – this may be a non-sequitor but it's relevant. As in a traditional maze there is a start and a finish. At the beginning of each game we see Hampton walking into the enticing looking

COMMENTS

Control keys: Q/A up/down, O/P left/right, bottom row to fire starch

Joystick: Kempston, ZX 2, AGF, Protek

Keyboard play: responsive and sensible positions

Use of colour: very good and varied

Graphics: good, smooth and well detailed

Sound: average

Skill levels: 1 with increasingly difficult screens

Lives: 5

Screens: 1

Originality: a variation on the 'Panic' platform type

General rating: above average, but not overaddictive.

| | |
|---------------------|-----|
| Use of computer | 65% |
| Graphics | 69% |
| Playability | 62% |
| Getting started | 68% |
| Addictive qualities | 55% |
| Value for money | 55% |
| Overall | 62% |

garden, the door slamming shut behind him – and he's trapped. There are four objects somewhere within the maze. Three are obligatory to find and one is helpful. The first is a map. As the maze is some fifty times the screen area, this is pretty essential if you are to find your

Hampton's Caught and without his glasses he's not likely to get out.

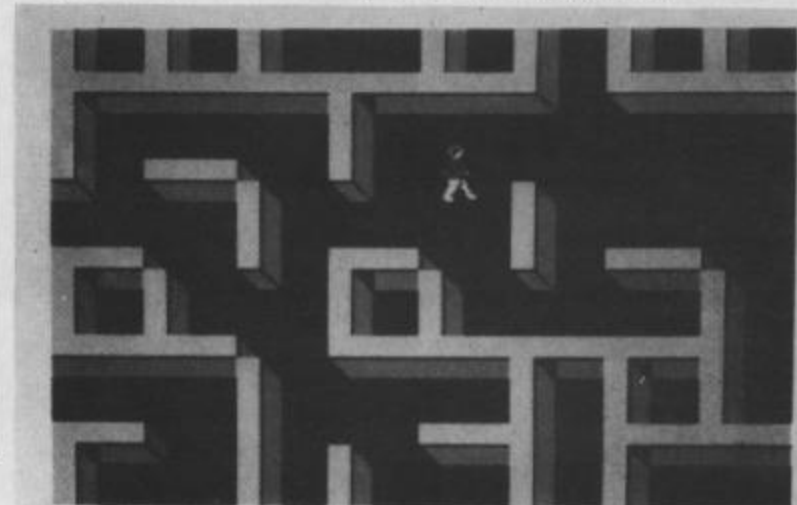

TIME LEFT = MIN 18 SEC 36

way out. Helpfully, it is normally to be found within a few moves from the start – if you know which way to start looking. The second object is a pair of spectacles which cures Hampton's short-sightedness and brings the third vital object into view on the map – the key to the exit. The fourth object is an alarm clock which adds a few vital minutes to the time limit against which the stirring escape is played.

That's about all there is to the game, except to say that the mazes (a different one is drawn each game) are extremely complex – a glance at the map is enough to terrify. The walls of the maze are seen from above in a simple form of perspective with the screen area scrolling as Hampton moves about. On the overall map Hampton's position and that of the key are shown as red dots.

CRITICISM

● 'Hampton is a simple game although the sheer size and complexity of the maze makes it more interesting to play than it sounds. But the real weakness of the game is shown by the fact that it is played against the clock (fine) but that the key is hardly ever visible until you have crossed three-quarters of the way towards the exit and almost always pops up virtually all the way back towards the start which means it is a struggle to make it out of the maze before the time runs out. In other words, excitement is being artificially introduced. As a result, and despite the different maze set up each time, the game lacks any serious lasting appeal.'

● 'Reading on the cassette blurb it said, 'Amazing sprite graphics and animation... 3D maze 50 times screen size.' The implication is that there are lots of animated sprites, when

there is only one – Hampton himself, and the animation isn't really amazing, it's quite ungainly. The 3D maze is a fake – if you are going to attempt to draw walls that look solid, then they should play a part as they do in, say, *Android 2* or *Ant Attack*, where the characters can disappear behind a wall. In *Hamptons Caught*, the 3D plays no part whatsoever. The four direction screen scrolling is very jerky, slow and eventually becomes tiring on the eyes. The maze is so large that it can take you all of the quite long time allowed to find how to reach the exit. Generally, I thought this was quite a disaster.'

● 'The graphics of the maze are very straightforward, whereas Hampton is quite a large character, fairly well animated and, unusually in Spectrum graphics, variously coloured, red shirt, blue trousers, yellow face and hands. His legs move in a rather ungainly way however! The game itself is not all that inspiring by today's standards, especially as it all moves rather slowly. Very frustrating when time's running out.'

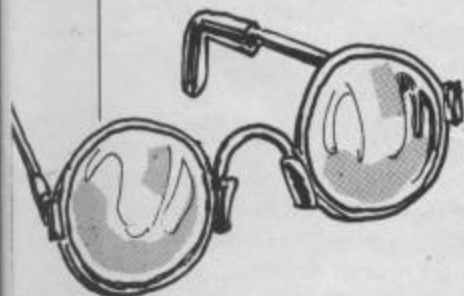

COMMENTS

Control keys: cursors
Joystick: Kempston, Protek, AGF
Keyboard play: not very responsive and awkward to control at times
Use of colour: reasonable
Graphics: no real use made of 3D, main character animation is inventive
Sound: poor
Skill levels: 1
Lives: against the clock
Originality: the concept is as old as the hills of course
General rating: below average.

| | |
|----------------------------|-----|
| Use of computer | 44% |
| Graphics | 47% |
| Playability | 38% |
| Getting started | 57% |
| Addictive qualities | 30% |
| Value for money | 42% |
| Overall | 43% |

With the summer season well under way, we thought we would take a look at two games on the subject of cricket. The noble English institution has been covered before by games for the Spectrum but these two are new.

Cricket

Producer: **T. J. Owen**
 Memory required: **48K**
 Retail price: **£6.95**
 Author: **David Owen**

Howzat

Producer: **Wyvern Software**
 Memory required: **48K**
 Retail price: **£5.50**

Of the two games *Howzat* comes in the more professional looking packaging with a full colour insert containing two pages of brief notes. *Cricket* has a yellow card insert with a line drawing on it and no instructions, but is accompanied by a large booklet containing playing instructions and many details on playing cricket in general.

In keeping with its packaging, *Cricket* is the less sophisticated program, although it has plenty of options, allowing play against 18 county sides. *Howzat* allows play against or selection from 17 county sides and 7 Test squads. Both games allow the player to select his own side and name them. In simulations of this sort, a printer is very useful – almost essential in the case of *Cricket*, and both games allow this facility.

CRICKET

On completion of loading you are asked to put CAPS LOCK on, as the program only accepts input in capitals. This seems a little primitive these days. You are also asked to type in '1' if using a printer, but there is no screen prompt to tell you anything else, although ENTER moves things along. A 12-option menu allows you to select a team, load or save one, play a county side, play another invented team and several other things like change the Over limit. Selecting your own team means typing in the name of 16 players, they are then given their various qualities and strengths and when playing another team or county side you

may select which 11 to choose.

Cricket offers a pitch analysis before taking the toss and informing you who has won. If it is you, you may elect to bat first or bowl. The game is non-visual – you select how many balls the game is to continue for, and the computer reports on each ball. When the number of balls selected for play are over it is possible to see the scoreboard and partnership details.

HOWZAT

Howzat is a graphics type game, which shows you the field and the position of the fielders, batsmen etc. In this respect it resembles CRL's *Test Match*. As the player you may select the bowler and set or change your field positions, moving them via the keyboard. Two games are provided for, one day cricket or a first class match. You may select a team from the options provided or create your own. The selected team is then displayed with the standard players and rest of squad, from which you may select the players you want. When this is done, the players' strengths in batting and bowling are displayed, but the skill factors may be altered if so wished.

When the toss has been decided, the field appears. Using the cursor keys it is possible to place a cursor over any player and move him to a new position. Between each ball it is possible to reset the field or see the scoreboard. Pressing the 'B' key results in the bowler running up and bowling. The stroke is taken automatically and the batsmen asked if they want to run or not.

The pitch in *Howzat*.

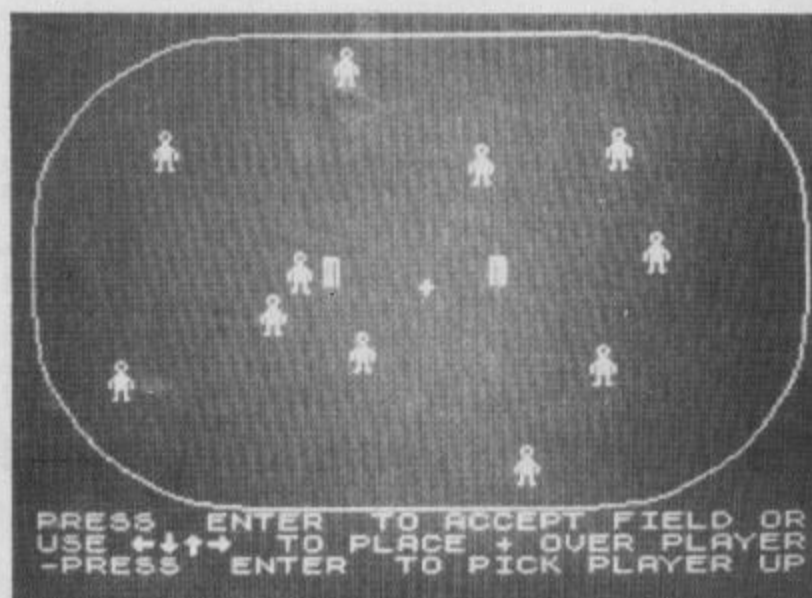

CRITICISMS

CRICKET

● 'This is another rather involved simulation. Don't worry over long delays – the prog is in Basic and these things happen. The game has no direct user involvement and there is no visible play, only screen messages. This left me rather cold. Such games should contain more user involvement – surely the idea of a game is for the player to get involved.'

● 'Cricket got off to a bad start – not many prompts informing the player what was happening. If a wrong input is entered the program crashes. Watching a TV screen with comments on what's happening in the game is just not cricket, and there are better such games on the market.'



Text-only screens in *Cricket*.

● 'The instruction booklet is quite lovingly done, but the game seems less so. It's very primitive programming which asks you to engage CAPS LOCK for input and expects you to wait ages for a response. Whilst I can believe that cricket fans may get fun from team selection and getting to know how the players 'work out', I can't believe that even the most ardent fan will enjoy sitting back watching a string of repetitive comments come up on screen informing him of what happened to each ball.'

HOWZAT

● 'Howzat has been apparently endorsed by an England Cricketer, Brian Rose. He says, 'It's a truly addictive game.' It is involved and accurate as to the selection of county, test sides, trophies and one day cricket. The user involvement is only to the point of making decisions on team selection and commencing playing actions. I would like it to be more interactive. I am sure that cricket fans will like it, but to the rest of us I would say beware - it tends to have the same effect as TV cricket (Zzzzzzz!).'

● 'Compared to Cricket, Howzat is much more slick, no need here to input and ENTER, the input is sufficient and the response almost instant. But actual play is very unrealistic. The bowler always bowls from the same end, no matter what over, and fielders move in steps to the ball to field it between each run you take. No skill is used to judge a run. Although not a cricket fan, I did enjoy CRL's Test Match, but this one left me cold, and I can't see it being in the least bit addictive.'

● Howzat has reasonably large characters, although no real animation is used. Moving the fielders around is not very realistic as you cannot put anyone very near the actual pitch. In the end, it seems most unrealistic to expect any sort of enjoyable skill from a game which requires a vast playing area in real life, when it is reduced to this size on a TV screen.'

COMMENTS

CRICKET

| | |
|---------------------|-----|
| Use of computer | 38% |
| Graphics | N/A |
| Playability | 25% |
| Getting started | 78% |
| Addictive qualities | 45% |
| Value for money | 40% |
| Overall | 45% |

HOWZAT

| | |
|---------------------|-----|
| Use of computer | 70% |
| Graphics | 38% |
| Playability | 50% |
| Getting started | 53% |
| Addictive qualities | 48% |
| Value for money | 58% |
| Overall | 53% |

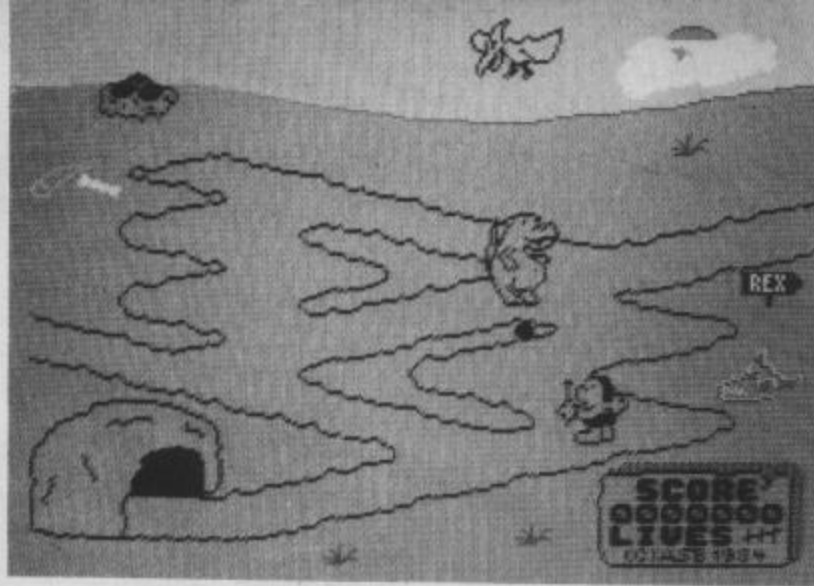

Zig-zag your way up to the pterodactyl's nest and steal the eggs.

Ugh!

Producer: **Softek**
 Memory required: **48K**
 Retail price: **£5.95**
 Language: **machine code**
 Author: **Tony Samuels, S. Beverly**

There are quite a few precedents for *Ugh!* First off, Ugh is a caveman - and we know there were a few of those about. Then there was the funny story of everyday cave life by an American radio comedian (Bob Ne-whart?) about how interesting a caveman's life was, living inside rocks, sitting on rocks, throwing rocks, eating rocks... Then CRL produced *Caveman*, which was all about stealing pterodactyl eggs, then Softek brought *Ugh!* out on the Dragon. Ugh also goes about stealing eggs from a pterodactyl, only now he does it in colour on the Spectrum.

The screen layout is fairly simple. At the bottom left is Ugh's cave and at the top left is the pterodactyl's nest. Between the two locations a wide path zig-zags upwards. Another path makes lazier zig-zags over to the right and there are some dead ends leading off this configuration. Ugh must make his way from the cave up to the nest, steal an egg and return to his cave for another egg. On his way up he is provided with a spear but has to abandon it to carry an egg. Fortunately life provides him with another once he returns to the cave and deposits an egg.

A spear is lost once it is thrown at one of the pot-bellied tyrannosaurus which shamble amiably along the paths in a random pattern. Once speared, the prehistoric reptilian retreats to the furthest edge of the screen before setting off again. Ugh's other problem is the understandably distressed pterodactyl which flies above the terrain at the top of the screen, dropping - yes, you've got it -

rocks. Bumping into a tyrannosaurus or getting hit by a rock causes instant death to Ugh, but he has three other relatives all called Ugh to take his place. With each screen cleared, there's a bit more to dodge.

CRITICISM

● 'The first thing to strike you about *Ugh!* is the title screen which is similar to the cover (full of nice cute little things). Once loaded, you are greeted by a catchy tune, then you have to sift through the various skill levels. All the graphics and sound are very good but my main grumble is the difficulty of moving your adorable caveman. This problem ruins the game which is otherwise well thought out and produced. If you forget its one fault, *Ugh!* is quite fun and I feel it could be a hit with a few adjustments.

● 'An attempt to produce a sort of 3D game here - quite unsuccessful though. It's difficult to move your man which makes the game hard to play. The screen layout is quite nice, particularly the way that the score and lives are set into a block of stone - very convincing. Colour and graphics are above average although there seems to be a slight lack of colour. In the end I don't think there's very much to *Ugh!* and it soon becomes uninteresting.'

● 'This is a very original idea, but tends to fall down in the actual working. It can get repetitive and boring when you have collected some eggs. Moving is not easy due to the screen design, the bends in the zig-zags are deep and you have to move your man to the furthest corner before he can change direction. The graphics are very good but I thought the colour could be better used, as, unlike the title screen, all the characters are just outlines on the basic colour ground. Above average, but lacking lasting appeal.'

COMMENTS

Control keys: user definable, four needed for direction and one for throwing spear
Joystick: almost any via UDK
Keyboard play: good, but limited
Use of colour: good, large, well animated and smooth
Graphics: good tunes (one reviewer even refers to it as music!), but poor during the game itself
Sound: 5
Skill levels: 4
Lives: 5 different paths
Originality: obviously *Ugh!* scores quite well
General rating: above average, original but lacking addictivity.

| | |
|---------------------|-----|
| Use of computer | 68% |
| Graphics | 69% |
| Playability | 56% |
| Getting started | 64% |
| Addictive qualities | 50% |
| Value for money | 59% |
| Overall | 61% |



TLL

Producer: **Vortex**
 Memory required: **48K**
 Retail price: **£5.95**
 Language: **machine code**
 Author: **Costa Panayi**

Tornado Low Level (TLL) is from the same programmer who brought us *Android* and *Android 2* and it bears a family likeness to the graphics of

Android 2. Again, we have a rapidly scrolling series of three-dimensional graphics which will move across the screen in any direction. The Tornado of the title is a swing wing jet fighter which you control in a mission to eradicate a series of evil dots on the landscape. In this respect all the missions can be seen as training, since the 'enemy' dots in question are spattered around the very buildings which make up the township around your base.

The total playing area is about 36 times the size of the screen display which consists of a square, offset so that to the right are the instruments. These include 'radar' view some 4 times the screen area on which targets appear as white dots, an altimeter, fuel gauge, targets destroyed status and time.

The landscape is seen, as in *Android 2* from a severe birds eye view perspective. Ground level is approximately one third of the way up the altimeter as features included are sea and cliffs, which means sea level is way below ground level. On the ground features include low and tall buildings, pylons and electric lines, trees, roads and bridges over rivers.

The game commences with a glimpse of the total playing area map, before cutting to the base with the Tornado ready at the end of the runway. Visually, height above the surface is indicated by the shadow of the aircraft which alters accurately depending on the terrain being flown over. Targets are destroyed quite simply by flying over them at virtually zero feet. There are five targets to destroy and when these have gone, more are provided in different positions.

Some targets are randomly placed, even in the water, which may mean underflying the bridge. If your fuel runs low it is possible to land and refuel, turn around and take off again.

CRITICISM

● 'TLL is a worthy successor to *Android 2*. One thing to be said is that it isn't actually as arcade exciting as *Android 2*, but that isn't a drawback, because it offers another sort of excitement, not quite simulation, not quite arcade, but somewhere in between. Although it is possible to destroy targets when you are visibly some feet above the ground, you get far more points if you are lower still, so there is a self competitive element in the

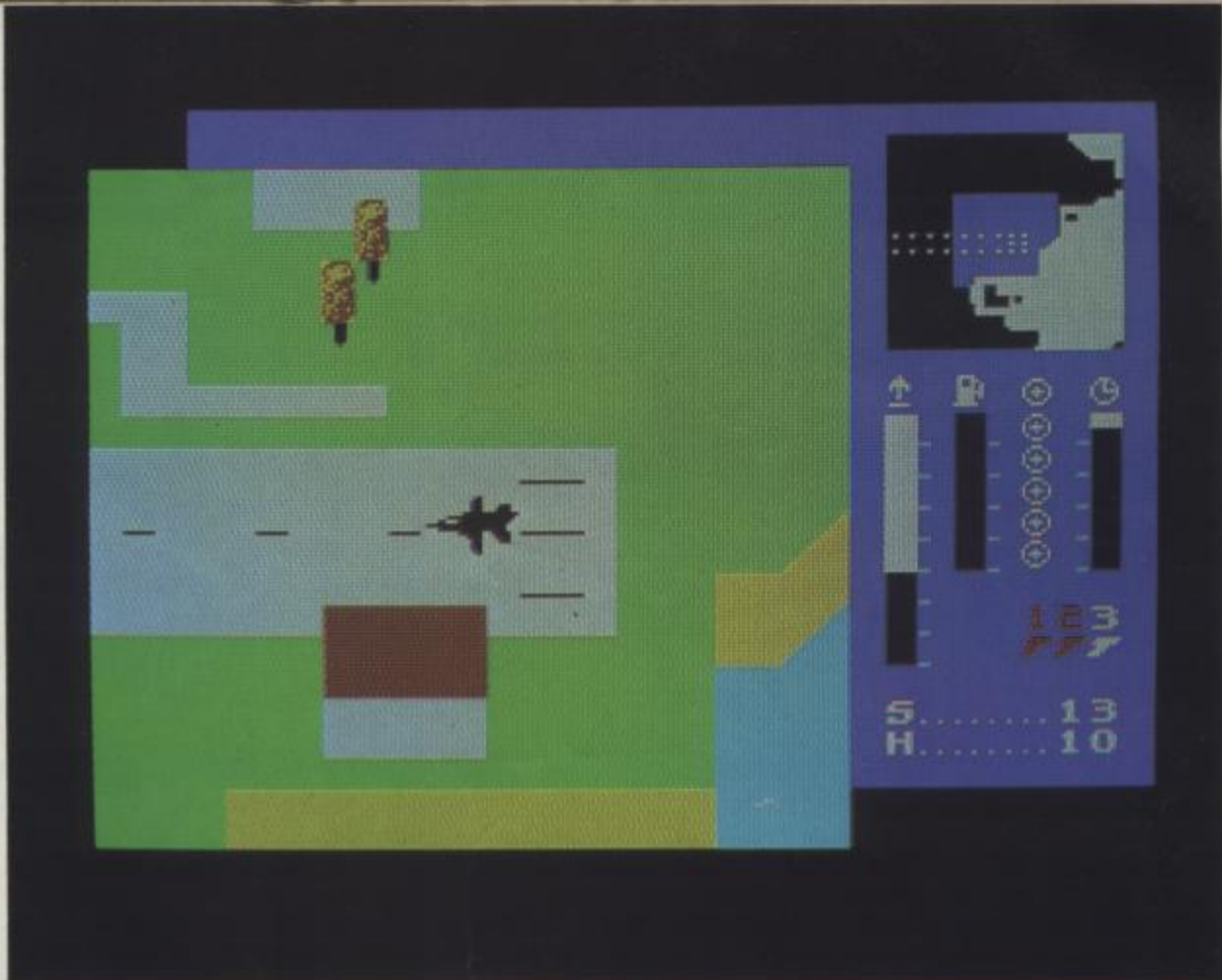

"Scramble TLL - 5 enemy dots at zero feet..."

game. Another thing to watch out for is that there is a tower too tall to fly over. The graphics are remarkably clean looking with a strong use of colour to define buildings, cliffs etc., and full use of normal and bright to create shadows. The 3D effect of your shadow works extremely well, breaking up quite accurately if you are half over a building. I enjoyed TLL as a very playable game and to date I still find it addictive.'

● 'Watch out for the 2-part loader. First part tells you to disconnect all peripherals except for the Sinclair add-ons. First time round I ignored it (never unplugging the Kempston) and the program crashed. TLL is, in a word, brilliant. The 3D effect really works, it's just as if you're looking down on a real plane flying over a landscape. The graphics are not super-detailed but are very good. I found this game playable and addictive and after a while I found myself flying under bridges, power cables and manoeuvring around trees at low level. In my opinion, this one takes the biscuit.'

● 'The shadowing works very well in this game to create a sense of depth. This includes the use of normal and bright colours on cliffs, buildings and bridges as well as the shadow of your aircraft. The only inconsistency here is that the aircraft shadow doesn't get bigger or smaller as you go up or down. Flying under bridges and high power cables works very well, as does the effect of low flying behind cliffs, where the shape of your plane may disappear

altogether. The only graphical crib is the lack of detail in the buildings, where maybe a few windows would have helped. Sound used is a fair roar or a beep, a nice touch is that on take off the engine note changes when you have achieved sufficient speed for take off. Perhaps a better white noise sound generation would have been better for engine sound. Instructions were not as clear as I would have liked and there appeared to be no real indication as to objectives, or how to go about them. I feel this game probably lacks a little in content, perhaps a few enemy aircraft would have made it more lively. Overall, quite good'

COMMENTS

Control keys: I/Q up/down, G/H bank left/right, X = take off or

change wing mode, M = map (on the ground)
Joystick: ZX 2
Keyboard play: responsive
Use of colour: very good
Graphics: mixed opinions from 'brilliant' to 'fair, needed more detail'
Sound: average
Skill levels: 1
Lives: 3
Screens: continuously scrolling
Originality: very original
General rating: playable, addictive and different, generally recommended.

| | |
|---------------------|-----|
| Use of computer | 83% |
| Graphics | 79% |
| Playability | 85% |
| Getting started | 70% |
| Addictive qualities | 84% |
| Value for money | 84% |
| Overall | 81% |

TLL's shadow - a graphic that really works



AVAILABLE FOR
ZX SPECTRUM 48K
TO BE CREATED FOR
COMMODORE 64
ORIC 1.48K ATMOS
BBC MODEL B
ELECTRON
AND OTHERS
£7.95

Following in the tradition of superb adaptations of the H. G. Wells classic: CRL in association with ORP proudly presents to the world of home computing the strategic arcade adventure 'The War of The Worlds'. Based on Jeff Wayne's internationally successful double album.

PRODUCED BY CRL

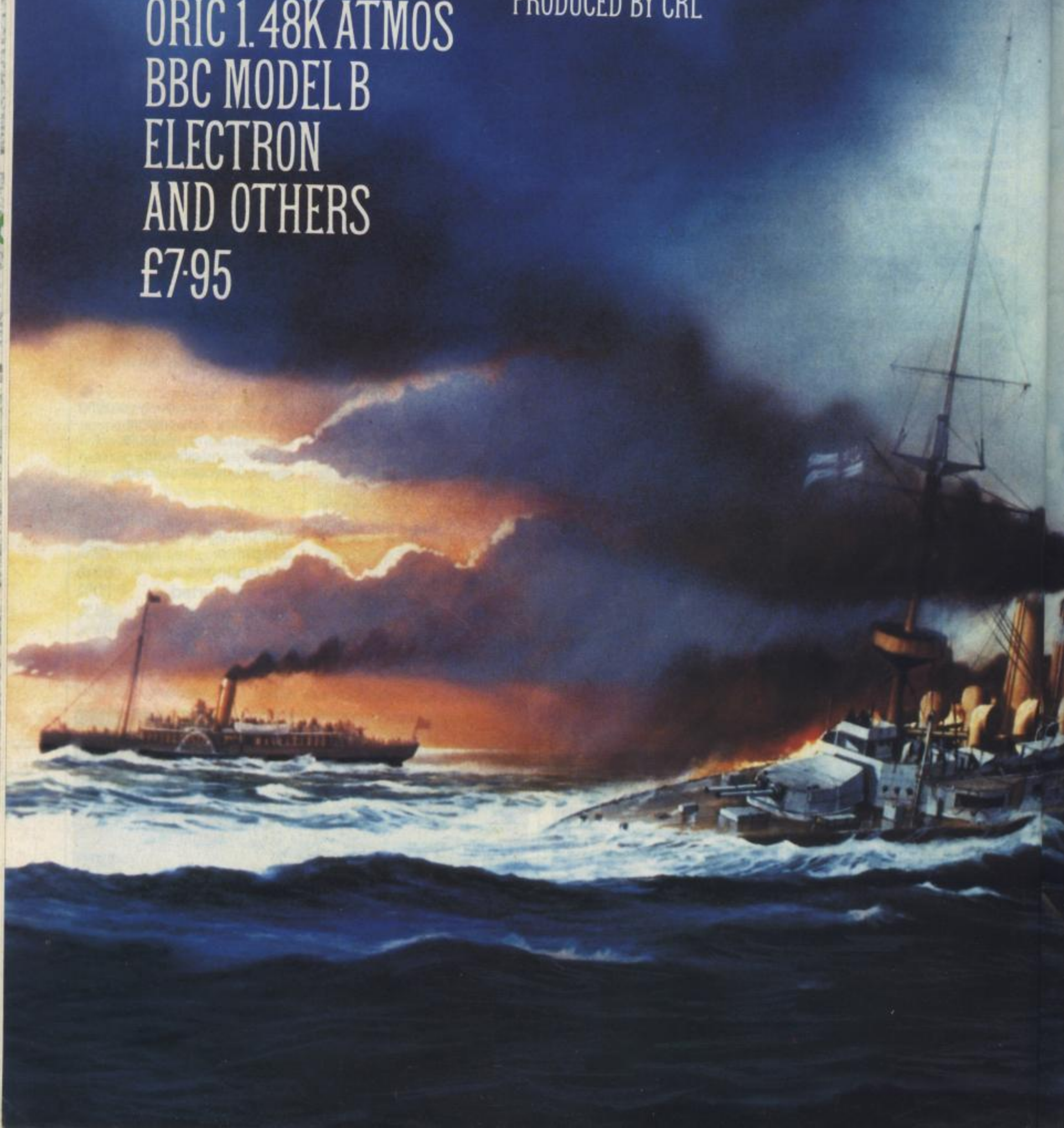

JEFF WAYNE'S VIDEO GAME
VERSION OF

THE WAR OF THE WORLDS



CRL
THE DREAM MAKERS

Jeff Wayne's version of the 'The War of The Worlds' copyright Ollie Record Production, New York, 1984.

CRL House, 9 Kings Yard, Carpenters Road, London E15 2HD. Tel: 01-533 2918

Crash
Competition

ULTIMATE
PLAY THE GAME

DRAW
THE



MAP OF

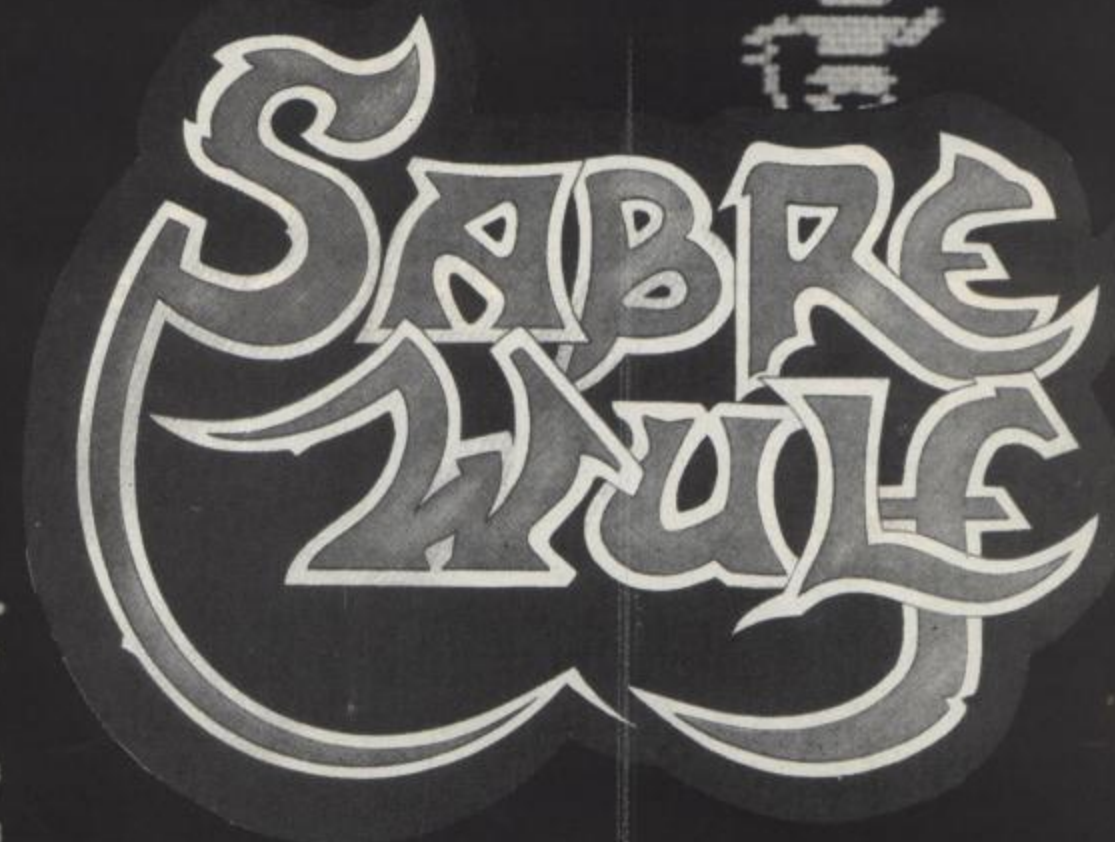

MAP COMPETITION

The success of our ATIC ATAC MAP competition has shown how many CRASH readers there are who can draw and present maps excellently. NOW HERE'S ANOTHER CHANCE TO HONE THOSE SKILLS.

In association with Ultimate CRASH asks you to don your pith helmet and mosquito boots and plunge into the jungles of SABRE WOLF armed with sword and theodolite to prepare a map.

The map can be as big or small as you like, although you'll obviously stand a better chance of fitting detail in on a larger format. It should show all the screen locations of course. How you present that is up to you, but we would like to see an indication of what actually makes up each separate screen image. This could be done with an overlaid grid for instance, but there are many other methods. Again, we want as much detail as you can sensibly fit in, using a key to objects and animals if you prefer that to including them actually in the map itself.

All the entries must be accurate of course, but we will be looking for overall presentation, use of colour and sheer imagination in the winner's entry. This will be used to prepare a poster-sized version to be printed in a later issue of CRASH.

Ultimate had a superb trophy of the **ACG Key** made for the *Atic Atac* competition, and they are now busy having another trophy made up for this one. **The winner will receive the ACG Amulet from Sabre Wolf.**

Maps should be sent to: **SABRE WOLF COMPETITION, CRASH MAGAZINE, PO BOX 10, LUDLOW, SHROPSHIRE SY8 1DB**, and should arrive by the last post **September 7th**. We have already received several maps from readers. It would be better for those people to have another go, but if they wish we'll accept them as entries for the competition.

The decision of the Editor will be final in judging the entries.

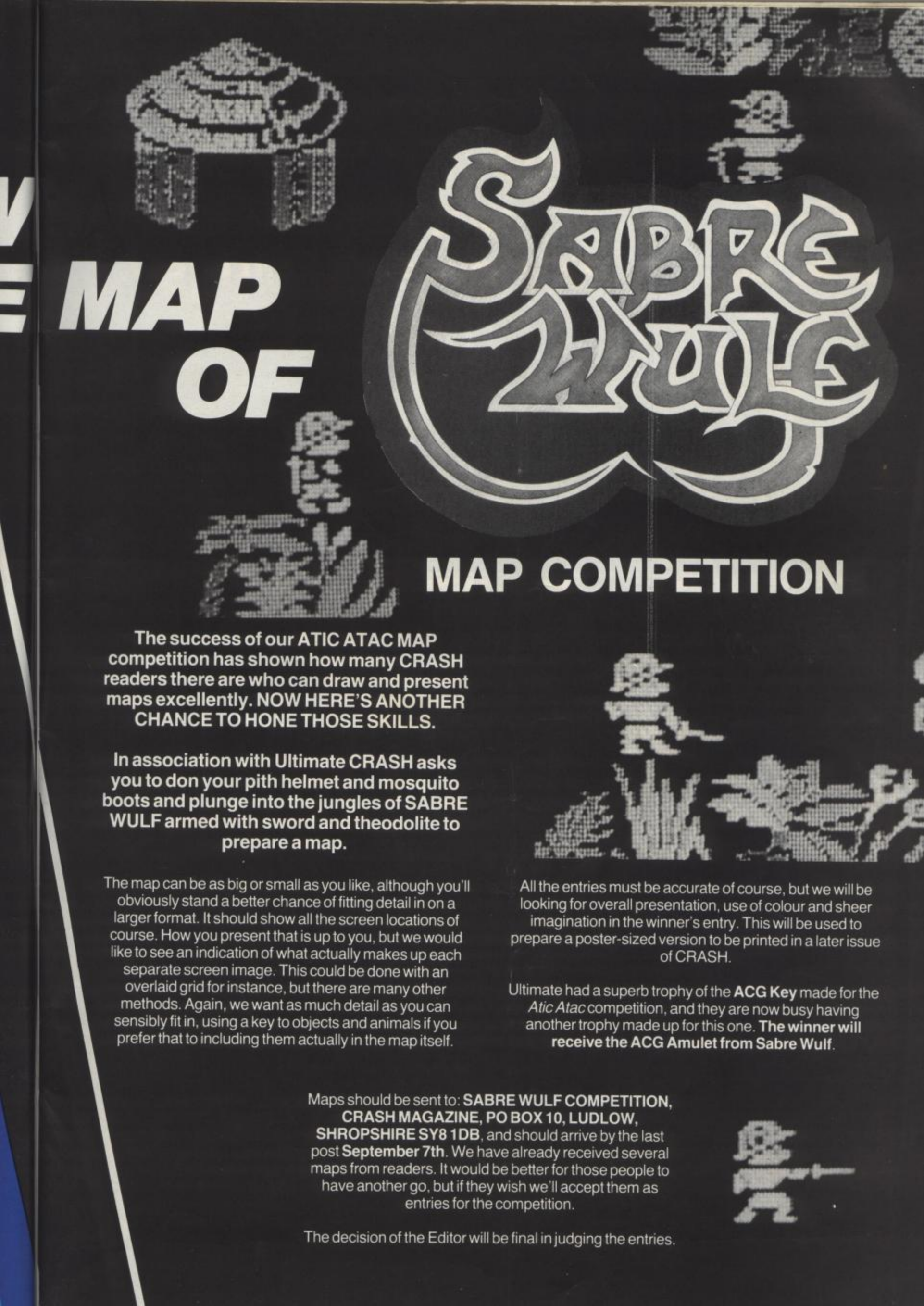

**Crash
Competition**

Melbourne House
Software for the
48K Spectrum

Hitch a ride on the Mugsy Art Racket and spot the fakes! 50 copies of Mugsy ride on it!

*Melbourne House, who brought you **Penetrator**, **The Hobbit**, **Terror Daktils** and taught you how to draw Melbourne on a Spectrum, now invite you into streets run by The Mob. Join Mugsy's gang of hoods and save him from an art forger, and the Godfather from donating the wrong picture to the Metropolitan Museum of Modern Art!*



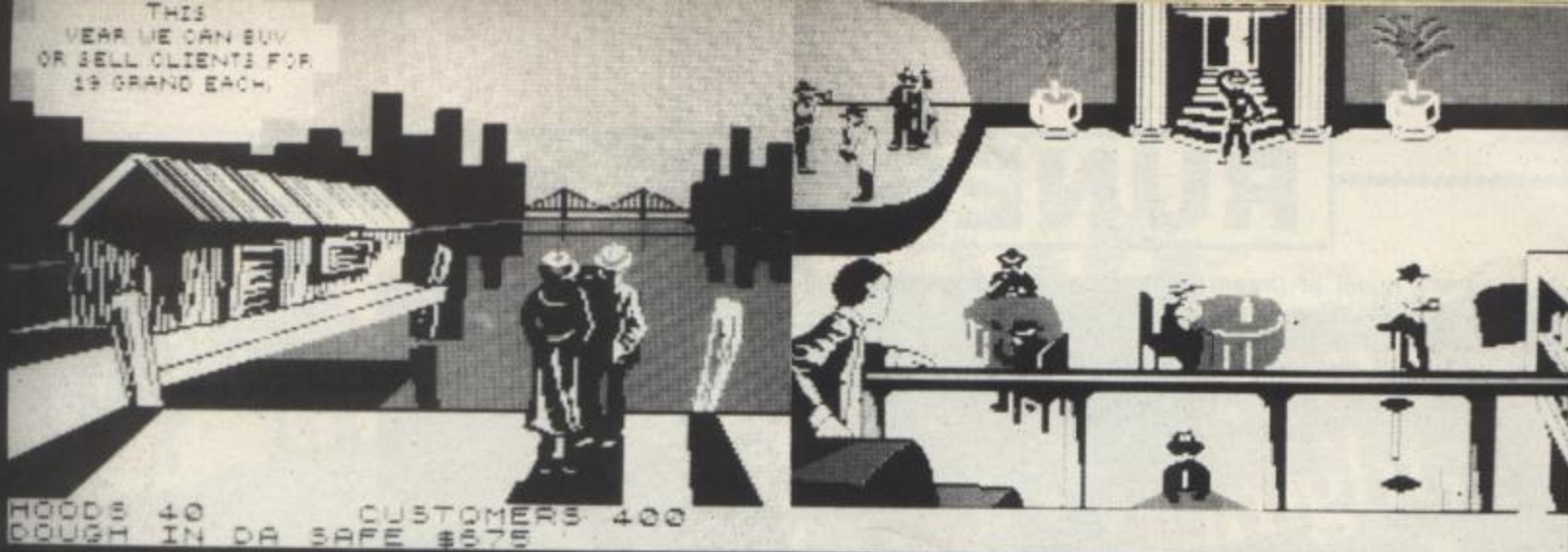

"Okay Mugsy – you's da boss for now. Jus' keep ya spats clean and ya hair parted, and de Gawdfather's agonna keep ya outa dat a great speakeasy in de sky. Trouble is, Mugsy, ya gotta have a keen eye to spot de fake from de high grade in dis a life, or it's coit'ns for ya – and ahm a not talking about Laura Ashley either.

"So dis is de big time, Mugsy. De Gawdfather wants wid dis here picture (it's art, see?) and de guys come up wid two! We don' know de real from de fake – so's it'sa down to you! De boys, dey say dere's thoity diff'rences between em. But can ya spot dem oil? You do well here, Mugs baby, an' de Gawdfather may put up some dough for bail next time de cops grab ya!"

(Loosely translated this means; there are 30 differences between the picture on the left and that on the right. Circle the differences on the **right hand picture** (or a photocopy if you don't wish to cut up the issue) and send it to the MUGSY COMPETITION, CRASH MAGAZINE, PO BOX 10, LUDLOW, SHROPSHIRE SY8 1DB.

Please remember to add your name and address!

Entries must be received by the last post August 30. The first fifty correct entries drawn from the bag will each receive a copy of **Mugsy** by Melbourne House.



RUNESOFT PRESENT

Enter the realm of Dream and Paradox — Survive 150 locations on what is probably the most difficult task you've ever been set — If you can!



Help Yaw Ning to find SPOOF the magic dragon, despite the whole world being set against him. Poor Yaw — You'll probably die laughing.

Popular Computing Weekly (15:04:84): "Paradox looks, from a quick play and the complex maps I've been sent explaining it, like one of the most complicated adventures ever designed ... addiction is probably ensured."

LOOK for the



★ ★ COMMODORE VERSIONS AVAILABLE SOON ★ ★
RUNESOFT artwork by Nick Bibby

PARADOX, SPOOF and SPECTREALM (a strategy game for budding Emperors), for the Spectrum 48K computer, are available from selected shops nationwide at the following prices.

**PARADOX: £7.50; SPOOF: £7.50;
SPECTREALM: £6.95**

In case of difficulty, ask your local stockist to contact his distributor, or send cheques/POs direct to:

RUNESOFT

Charnwood House, 67 Lower Parliament St, Nottingham NG1 3BB. (Tel: 0602 (STD) 287667 & 271748)

Commodore 64 & BBC 'Model B' Users

NOW YOU CAN JOIN IN THE FUN OF KEVIN TOMS' No. 1 Football Game

FOOTBALL MANAGER



Football Manager

Designed by Kevin Toms
This outstanding game of skill and strategy is now widely available and you can join the many thousands of satisfied customers who have purchased the game.

Some of the features of the game:

- Matches in 3D graphics
- Transfer market
- Promotion and relegation
- F.A. Cup matches
- Injury problems
- Full league tables
- Four Divisions
- Pick your own team for each match
- As many seasons as you like
- Managerial rating
- 7 skill levels
- Save game facility

Action from the game (CBM 64)
"The Highlight sequences are pure magic. And then you have to sit on the sidelines and sweat it out! Completely fantastic. I want one!"

Quote by Charlie Nicholas
Reprinted from Bet K

Prices: BBC Model B £7.95
Commodore 64 £7.95
Spectrum 48K £6.95
ZX81 16K £5.95

(N.B. 3D GRAPHICS ARE NOT INCLUDED IN THE ZX81 VERSION)
Overseas orders add £1.50

Strategy Game of the Year, 1983 (Nominated)
Golden Joystick Awards

Addictive

Available from computer software stockists nationwide including selected branches of

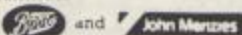

Addictive Games

7A RICHMONDHILL, BOURNEMOUTH BH2 6HE

To order by mail (p&p free) send cheques or postal order to:



To . . . Beyond Competition House,
Farndon Road, Market Harborough,
Leicestershire LE19 9NR

Please send me . . . Qty Total Price

PSYTRON £7.95

SPELLBOUND £5.95

THE LORDS OF MIDNIGHT £9.95

BEYOND ORDER HOTLINE
0858 34567

BEYOND ENQUIRY HOTLINE
01-251 8496

GRAND TOTAL

all prices include p&p

I enclose a Postal Order/Cheque payable to Beyond, or charge my credit card.

Card Number _____
Access/Visa (Delete as necessary)

Name _____

Address _____

Post code _____

Signature _____

Please rush me details of the 'Enter the Beyond' Software Club.





We can't show you all the views
of the Lords of Midnight,
there are **32,000!**



We've invented a new programming technique called Landscaping, creating a completely new kind of game, the EPIC. You'll get the chance to shape the characters into your own fantasy novel by playing out the different rôles in the ever changing world of Midnight.

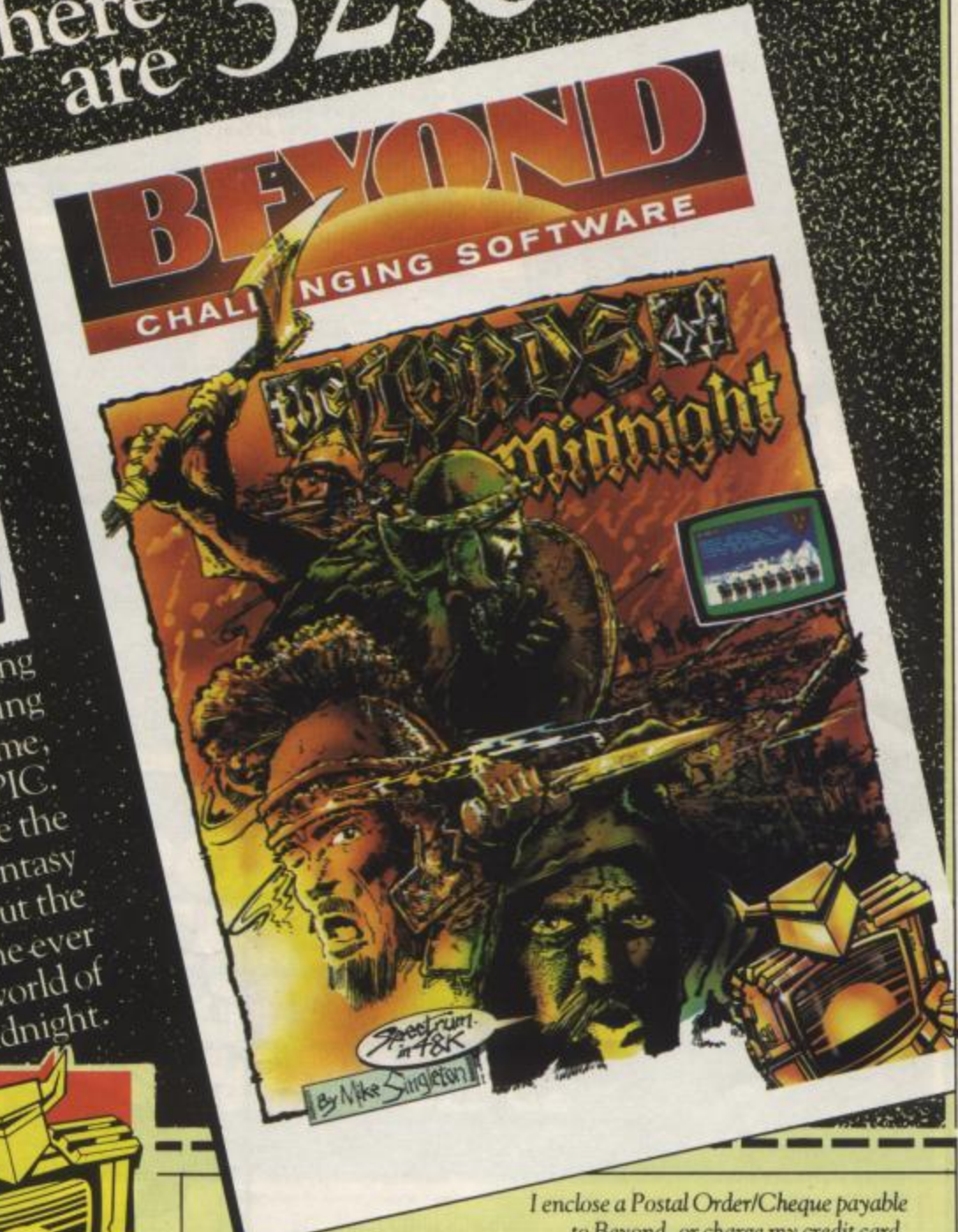

To . . . Beyond Competition House,
Farnon Road, Market Harborough,
Leicestershire LE19 9NR.

| Please send me . . . | QTY | Total Price |
|---|-------------|-------------|
| THE LORDS OF MIDNIGHT £9.95 | | |
| PSYTRON £7.95 | | |
| SPELLBOUND £5.95 | | |
| BEYOND ORDER HOTLINE 0858 34567 BEYOND ENQUIRY HOTLINE 01-251 8496 | GRAND TOTAL | |

all prices include p&p

I enclose a Postal Order/Cheque payable to Beyond, or charge my credit card.

Card Number _____
 Access/Visa (Delete as necessary)
 NAME _____
 ADDRESS _____
 POST CODE _____
 SIGNATURE _____
 Please rush me details of the "ENTER the BEYOND" Software Club . . .

C.7.



**IF ANDROID TWO
MADE THE CRITICS RAVE,
T.L.L. WILL GIVE THEM
HYPERMANIA.**

And why not?
It has the finest graphics yet to emerge from
a Spectrum game.

Fly the latest swing-wing fighter
bomber, with full 360° control.

Seek out and destroy enemy targets.
Land, refuel, take off at will.

With 3D multi-screen, multi-directional
wraparound landscape, it's guaranteed to give
your brain hypermania.

Fly Tornado Low Level today - just one in a
series of mindblowing action games.



PLEASE RUSH ME

- | | | | |
|--------------------------|-------------|------------------|--------------|
| <input type="checkbox"/> | T.L.L. | SPECTRUM 48K | £5.95 |
| <input type="checkbox"/> | ANDROID TWO | SPECTRUM 48K | £5.95 |
| <input type="checkbox"/> | ANDROID ONE | SPECTRUM 16K/48K | £4.95 |

TOTAL VALUE **£**

Games suitable for keyboard and joystick.

NAME _____

ADDRESS _____

BLOCK LETTERS PLEASE

Enclose PO/cheque payable to VORTEX SOFTWARE and send to
VORTEX SOFTWARE, 280 BROOKLANDS ROAD, MANCHESTER M23 9HD.

DEALER ENQUIRIES · CALL 061 973 9580

· VORTEX ACTION GAMES · AVAILABLE FROM ALL LEADING RETAILERS ·

LETTERS

Each month I'll be choosing the best letter from the postbag, and, as well as publishing it, I'll send the writer £12 worth of software of his or her choice (it can be two cassettes as long as they come within the £12). I've had to grovel on bended knee to the editor for this, so you'd better be grateful!

Send your letters to **Lloyd Mangram, CRASH Forum, PO Box 10, Ludlow, Shropshire SY8 1DB**. I can't promise to print everything that comes in because space is precious (I'm told) but I'll do my best.

Well, what a hectic month. I thought everyone said it gets quiet as summer comes on. In addition to the 3,500 plus competition entries (nothing to do with me thank goodness!) there have been literally hundreds and hundreds of letters to the Forum. I could probably fill two magazines with only letters this month, but that isn't on! As a result there are going to be a lot of disappointed letter writers who won't see themselves in print. Sorry about that, but all your letters do get read and the points absorbed.

Recurrent themes this month have been Mastertronic games, Sabre Wulf of course, and Spirit Software. Many of your letters are filled with over the top compliments to make a worn out letters editor blush, although none of you fool me, I know it's only the £12 worth of software you're really grovelling for. At a brief glance I particularly liked Julian Hiscock's kind comments - 'I think your magazine is excellent. It is an amazing, indispensable, fact-packed, fun-filled, witty, devastating, critical, complementary, colourful, error-ridden magazine, and is much the best use I can think of for a tree.' Thank you Julian, and no it doesn't make you letter of the month. In fact choosing a letter this month was extremely difficult, and in the end I decided on the following useful letter for would be do-it-yourselfers...



EASY TO FIT!

Dear Lloyd,
When I first bought my Spectrum it was a 16K, and after a few months I decided to upgrade it to 48K. Instead of spending £50 for the RAM pack I spent £30 on the D.I.Y. Chip Set. Good idea, I hear you say? Well, to anybody wanting to do this, take care:

On the instructions written in nice, friendly, easy to read words it said, 'EASY TO FIT WITH NO SOLDERING.'

Don't be fooled, it took me three hours to fit the chips in (is that a record?). Also, for the issue three Spectrum you have to do an intricate piece of soldering, which should be left to a skilled electrician as intense heat can damage the computer.

After this, I switched on the power and the TV. OOH! The screen was flashing and there was no use of the keyboard. Back to the shop it went.

I turned out that there was a faulty chip. Out they came and in with a new set. Problem solved? No! The screen had stopped

flashing and the keyboard worked, but it wouldn't load a 48K game.

We had a phase of ideas like rubbing the chips with tin foil to cut out static. Still no go. In the end the shopkeeper took the machine to an electrician and it was gone for a month. When it came back, it worked! R. C. Johnsons (the shopkeeper) have a list of D.I.Y. chip faults about as large as the Blackpool Tower (well almost), many of which are from leading manufacturers. So all of you hopeful upgraders out there - take care!

Anyway, thanks for a brilliant magazine. What happened to the Terminal Man in issue 5? How dare the artist fall ill when our hero is marooned on an Alien planet! It's just not on.

Alan Bates, Grimsby, South Humberside.

Thanks for the warning, Alan, and £12 worth of software on its way, which might go some way to making up for your troubles with chips.

LM



UNREPENTANT

Dear Crash,
If I were to say that your reviews are the only ones worth reading, it would not be good for your souls so I won't bother. As author of *Psi-Spy* I was delighted to see it reviewed in July, but make no apologies for the fact that your reviewers found it hard to fathom out! It is not a game for the faint hearted, but I will say that nothing that happens does so by chance, and all the clues needed to solve the problems and discover the objectives are contained in the instructions. However, if anyone is really stuck (surely not!) they can get in touch with me or contact Postern.

If you thought that one was tough, I fully intend to make the next one a good deal harder. See, I'm not in the least contrite!

Yours faithfully, **John Keneally,**
33a Commercial Road,
Weymouth, Dorset.

More next month in our new *Upset a Programmer* column! Thank you, though, for your letter, John - so now you know where to go if you're pstuck psi-spy, crashers.

LM

DISPIRITED SOFTWARE

Since Mr Johnson's letter regarding the bogus company *Spirit Software* was published in *CRASH* we have received numerous letters and phone calls on the subject, largely telling the same sad story of unanswered letters and answering machines, no game, no money. Just in case anyone is still in any doubt about the matter, contact Detective Sergeant Condon at Kensington Police Station, 72 Earls Court Road, London W8 6EQ, phone 01-741 6212.

Paul Steel of Maghull, Liverpool writes:

I hope they get what they deserve, which is not enough, I feel. It is people like this that give the little Spectrum software houses bad names and take advantage of the computer age by advertising non-existent programs, trying to cash in on the innocent public and their money. I say bring back hanging and throw them into the Gollum's den for Gollum to strangle.

An interesting point in all this is the problem magazines face in booking advertisements from new companies. **Andrew Herrera** of Birmingham says:

My view of this is that any advertisement going into a magazine should be that of a responsible company which has a good background, like Ultimate of DK'Tronics. Little companies which have never been heard of before shouldn't be trusted by mail order.

The problem with that argument is, of course, how do you know who's to be trusted? Even big companies start off little. A magazine can make credit checks on a new advertiser, but it takes time and is often quite unhelpful. As distribution of software has improved and the increase in retail outlets has made mail order less important, most of the bigger houses don't need mail order coupon ads. But for a new software house it takes time before retail outlets handle the games, and their only way of making money and getting on with their business is to start with mail order. We should look at things in perspective - yes, it is upsetting when someone like *Spirit Software* actually sets out to rip people off, but be honest - it doesn't happen all that often.

LM

WASTE OF SPACE

Dear Crash,
Although I enjoy reading your magazine I have several criticisms about the last issue (5). Okay, so it might be of equal value to the games player to be told what is rubbish as opposed to what is out of this world. However, instead of devoting half the mag to some pathetic company who calls itself

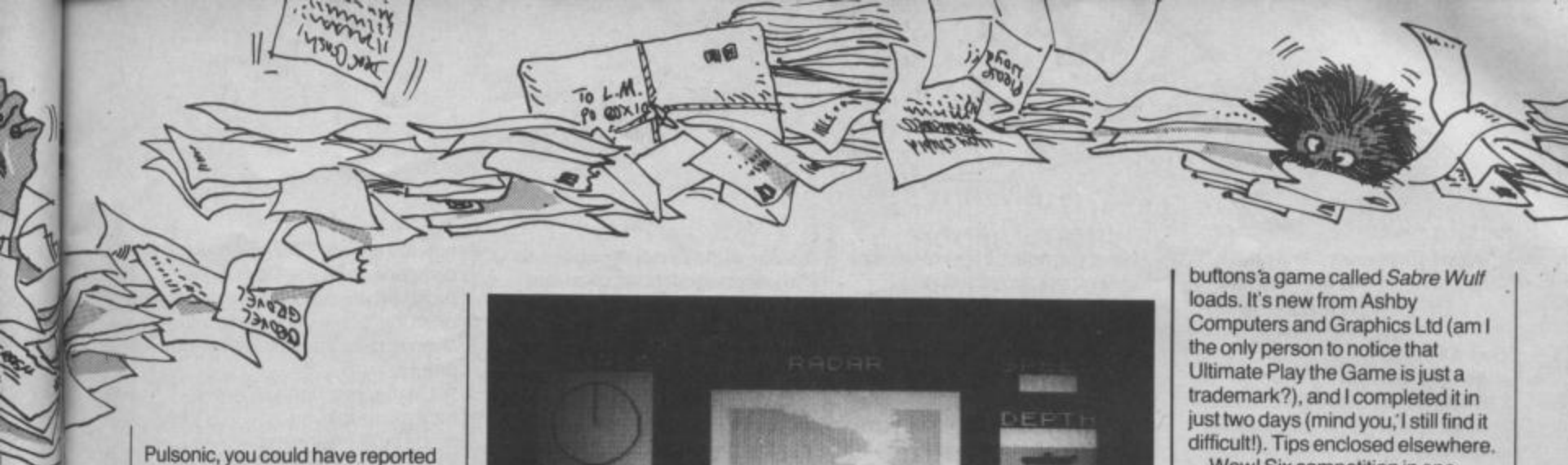

Pulsonic, you could have reported on some promising games like *Jack and the Beanstalk*, *3D Bat Attack*, *Blade and the Warrior* and the latest Sinclair releases.

I was a little puzzled by the way readers' letters are treated. Sometimes the comments are very helpful; other letters get a very cynical reply.

Bob Jenkins, Farnham, Surrey.

Other readers agreed with Bob (about Pulsonic games reviewed). As to my replies – surely no one could ever accuse me of being cynical!

LM

Dear Lloyd,
In the recent June issue there were no less than 8 games by Pulsonic. I think that it is an unfair amount of coverage as there are doubtless other new and established software houses who would want to have their games reviewed. There might be justification for this number of games by the same company if they were of particularly high quality. However, 7 of the 8 games got a CRASH rating of below 50%, and one got an overall rating of 17% and addictive qualities of just 1%! This sort of standard is not acceptable by today's high quality of computer games. So please don't clutter up your pages with this rubbish, especially in such numbers, and so keep up the reputation of CRASH as the best computer magazine on the market.

Tom Cliff, Maidstone, Kent.

There have been a few letters complaining that we haven't reviewed any games by *Mastertronic* (£1.99 a cassette) which are now appearing in many newsagents near the till. The reason is that they have consistently refused to send any review copies (I think we're buying some now!). The point is that some letters have complained because they think the games are good and should be reviewed, others have complained because they think they are awful even at £2 and we should warn people off wasting money. *Pulsonic* put out a large number of titles with no advertising to speak of but with a pretty heavy saturation of department stores. Would we have been fulfilling our duty as a review magazine to ignore them? (They were sent to us for review?) What would we say to people who rang up, perhaps to complain, who said

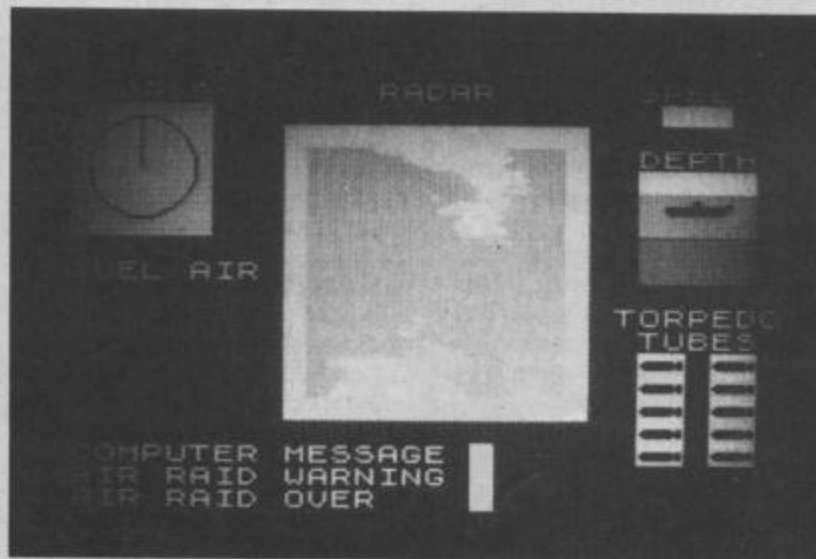

The command centre of *Submarine Strike*.

that they wouldn't have bought the game had we reviewed it first?

The thing is, CRASH is a review magazine for good and bad games. Perhaps you might argue that we should devote less space to games we think are rubbish, but we still try to do everything in as much detail as space allows. However, not everyone agrees entirely with the previous writers.

LM

MISRATED

Dear Lloyd,
Glad to see reviews on some of the cheaper software, e.g. Pulsonic. I bought two for school hols, *Mission Omega* and *Submarine Strike*. Very disappointed in *Mission Omega* – your review came a bit too late, but *Submarine Strike*, I and the two boys, Jason and Lloyd, have enjoyed it. I mean, at £2.99 what do you expect? By the way, we gave it 75%, thinking your 49% was a bit unfair.

Mrs M. Naylor, Leeds.

Can't win, can you!

LM

NOT SATISFIED

Dear CRASH,
I have recently bought the latest Ultimate title, *Sabre Wulf*. After the large sized box caught my eye, I paid £9.95 eagerly and rushed home. After being a bit put off by the title screen, which is not up to Ultimate's standard, I settled down, to my horror, to find that this over-priced game is merely a rewrite of *Atic Atac*. The principle of the game is the same, the movement of the man, the movement of the aliens, the noise of your man walking – all exactly the same. The objective is to find 4 hidden parts of an amulet. Now doesn't that sound the same as finding 3 parts of a key? Even the percentage given at the end is

exactly like *Atic Atac*. The only substantial difference is that you are in a maze instead of rooms. But really, an unoriginal *Atic Atac* rewrite, maze game from such an experienced and loved company is just not on, even more so with a price tag of almost £10. What do Ultimate think they are doing?

Jason Keeley, Maidenhead, Berks.

Well *Sabre Wulf* certainly put the cat among the pigeons (or is it the wulf among the hippos)? There are a few complaints about the price, and a few about the similarities to *Atic Atac*, but in the main everyone seems pretty happy. The next few letters are about many items, but they all have *Sabre Wulf* in common...

LM

SPEECHLESS

Dear Lloyd,
Yet another black thing with a hole in the middle? Well, no actually mine's a rectangular black thing with two holes, but when I put it in my cassette player and press the right

buttons a game called *Sabre Wulf* loads. It's new from Ashby Computers and Graphics Ltd (am I the only person to notice that Ultimate Play the Game is just a trademark?), and I completed it in just two days (mind you, I still find it difficult!). Tips enclosed elsewhere.

Wow! Six competition in one issue (5)! I was speechless until I worked out that it would cost me at least 3p more than CRASH to enter them all. How about setting aside a page with space for answers to all the competitions? This would save us readers a lot in postage.

However, minor quibbles apart, one only has to turn to the letters pages to see the high standards set by you, Lloyd, which the rest of the magazine somehow manages to keep up to. Your intelligent replies to our letters are a joy to read. More letters pages please!

Oliver Broadway, Finchley, London N3.

Well – what can I say? It took a lot of self control not to award you letter of the month, Oliver. But I have to be careful otherwise he who is occasionally obeyed would think I was giving in to a spot of grovelling. Going on to competition replies, there's nothing to stop you sending in all the replies in one envelope. It's only common sense that's needed – the various entries have to go into different bags (actually they're Sainsbury boxes but never mind), so you must make the sorting dept's life easy for them. This should save a bit on postage surely?

LM

NOT ENOUGH PRAISE

Dear CRASH,
I have just bought *Sabre Wulf* and I can't praise it enough. The graphics of the jungle are fantastic and those of the mountains and the temple area are just as realistic. This is by far the best yet of the Ultimates and

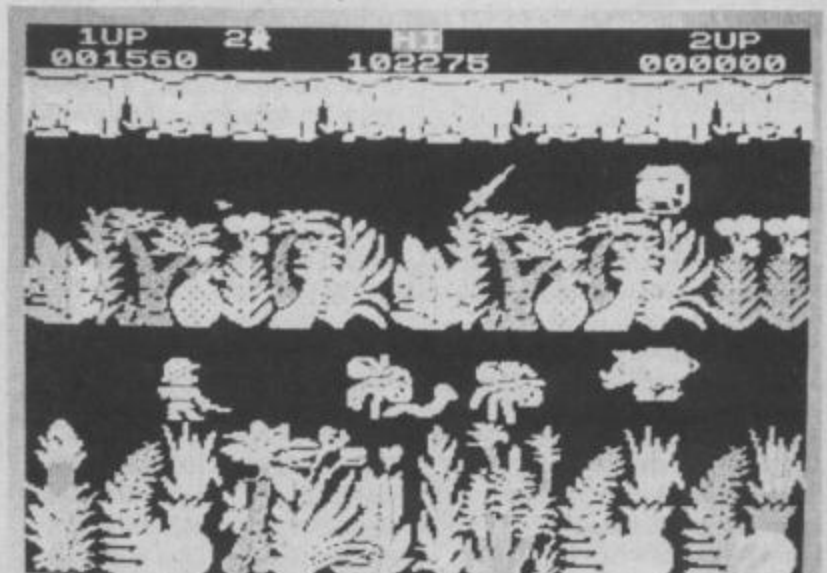

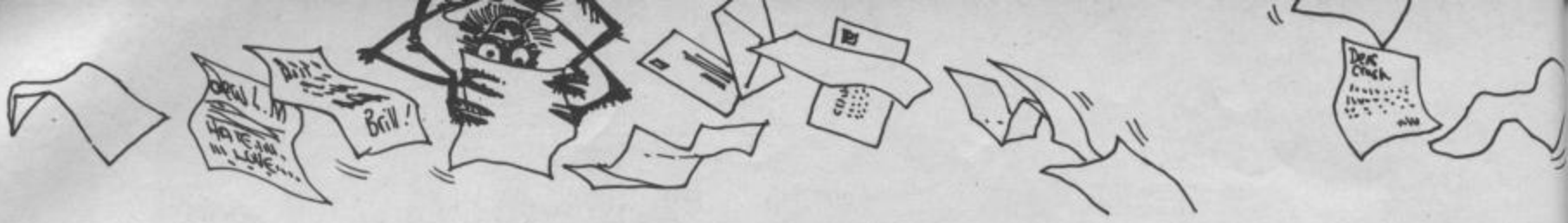

is worth every penny of the price.
J. Shepherd, Fincham, Norfolk.

Dear CRASH,
I have just received the new Ultimate game, *Sabre Wulf*. It really is an incredible game with fantastic jungle graphics and addictive qualities. (More tips in *Playing tips* - LM.)

Mark Philpott, Redditch, Worcs.

Dear CRASH,
I'm writing to you because I feel I must congratulate Ultimate on another brilliant game; *Sabre Wulf*, it's just so addictive. The graphics, sound and colour are typical of Ultimate, in other words, fantastic. Even at £9.95 it's a bargain. Ultimate have done it again!
Stephen Davison (13), East Herrington, Sunderland.

Dear Lloyd,
In issue five you threw down the gauntlet to make **THE** map of *Atac Atac* in one of your competitions. I think you have mistimed it a bit, because now that *Sabre Wulf* has been released, how can anyone pry themselves away long enough to do the other map?
Chris Kaye, Birkenhead, Merseyside.

Well pry yourself away from the screen long enough to do the *Sabre Wulf* map competition, Chris. Out of interest I counted up the letters received about *Sabre Wulf* over the first week of the game's release. We received 36. Only one complained about the game in any serious sense (printed 6 letters above). Three made a mention of the price being too steep, although otherwise happy with the game, the rest were all full of praise. Most started off with the line: 'I must be the first person in the country to have completed *Sabre Wulf*...' Well I guess someone must have been!
LM

CRASH No 5

Dear Letter-Reading Lloyd,
I walked into my local WH Smith not particularly looking for CRASH. But luckily I saw the familiar logo peeping out from behind the covers of *Computer & Video Games* and *Popular Computing Weekly* (obviously in good company - LM). Yippee! Hooraa! Skill!
I looked at the stunningly brilliant graphics of **Oliver Frey** and then was almost bowled over - SEVEN competitions in one magazine. Had Roger (King) Kean been overpowered by the money-lusting, power mad, micromaniac Lloyd?

Have you noticed how previously excellent, low priced software companies are raising their prices? I must say, the games you are reviewing are getting poorer. I personally think your overall value for *Psytron* of 91% is too high. Sure, graphics and actual game design is brilliant, but I find it rather confusing and, dare I say it, boring. With increasing numbers of glossy and colourful pages in your mag, I hope you don't have to increase the price from 75p. I liked the sort of interview with **New Generation** - more please. **One thing about magazines, which I'm afraid you're doing as well, is putting things that have to be cut out (such as competition entry forms) on the reverse side of reviews etc. Please put them on the reverse side of ads.**
Leigh Hunt, Norbury, London SW16

There have been, perhaps, less really good games to review over the early summer months. As to company profiles and the like, we are planning quite a few more in issues soon, as well as one on Ultimate from the inside. You wouldn't believe how hard it is getting into Castle Ultimate! Planning an issue so that cut out coupons fall in the right place is extremely difficult. One idea is to have a page devoted solely to such coupons, but it looks rather boring and may well cause confusion. In the main we try to opt for competitions which don't require anything to be cut out, but of course you can't always restrict yourself to that type. As to a price increase, I'm sorry to disappoint you, as you may have read in the Editorial, CRASH is going up in price. We're all a bit unhappy about it but it was either that or another cut in my salary.
LM

TALE OF WOE

Dear Lloyd,
I have to complain about the repair department of Sinclair Research. Please tell me if Sir Clive has employed Vera Duckworth in the despatch department? My tale of woe started 3 days after Christmas when my Spectrum broke down. Back it went to the shop where we were told it would take four weeks to repair. Okay, I thought, I'll start to learn BASIC (little did I know I'd have enough time to learn machine code before it came back!). After four weeks we went to the shop, who said the Spectrum wasn't back because of the Christmas rush. They said give it another two weeks. We did. By the time I went for the third time March was here so I demanded my money back. They said that I could not have any money

back until the computer was back. So I stormed out of the shop and went and got another Spectrum from a reputable computer shop, and waited for my money back from the other shop. On June 5th, SEVEN MONTHS after it was sent off, the computer came back. Is this a record? (No, not a black thing with a hole in the middle).
Stewart Jones, Kingswinford, West Midlands.

It could well be a record, Stewart, although the black thing with a hole in the middle would appear to be Sinclair Research's repair department. The real problem would appear to be the very high number of series 3 machines that have developed faults and need repair.
LM

PRAISE BE TO FREY

Dear CRASH,
Many people have written to you praising CRASH and its reviewers, praise to which I too hold, but nobody has yet commented on the ability of your ace artist, **Oliver Frey**, to capture the world of computers in his cover pictures. The best, in my opinion, was on the cover of issue 5 (June) and I would like to know if it is possible to obtain prints of this or any other of Oliver's paintings. By the way, I would have grovelled to Lloyd Mangram in order to get the £12 of software, but I felt it was about time the other members of the team got a mention.

I think Derek Brewster's *Adventure Trail* will be a great asset to your magazine.
Gareth Jones, Gerrards Cross, Bucks.

Easy come, easy go - if you don't want £12 worth of software, I suppose that's up to you. Besides, Oliver gets a lot more money than me - rucks of money (as they say up here in Shropshire). Still, I'm never one to complain - unduly. We may be doing some posters or a calendar nearer to Christmas.
LM

SLIPPING STANDARDS?

Dear Lloyd,
I keep reading in your magazine, and others, that the standard of computer software is rising. If this is the case, how come the worst rating in CRASH has dropped from 47% (*Apple Jam*, March) to 16% (*Hairy Wilfred and Co*, June), and the number of games gaining over 90% has dropped from 4 (March) to 1 (June)? Apart from that, prices are rising: when the Spectrum was first introduced software was £4.95 -

now it is around £6.50. Software companies just want to grab the profits off unsuspecting buyers and often the 'graphical experience of a lifetime' turns into a crummy BASIC program.

On the other hand there are exceptions to every rule. This one is made by **Mastertronic** whose £1.99 programs are in the Smith's Top 10, proving that quality is not always expensive. I hope to see these reviewed soon.

In fact, if it wasn't for CRASH I would have given up trying to pick a good game before I buy. CRASH helps us choose good software, but is there that much to choose from?
Robert Burgess (13), Rotherham, South Yorks.

I think there's still plenty of good software to choose from, certainly better written and more varied programs can be found today than could be two years ago when it was £4.95. Things do have to increase in price as time goes by. Good games today, take far longer to program than the much simpler ones that were around when the Spectrum had just been launched. Of course there's also a lot of rubbing priced at around £6.50 - there was as much when £4.95 was a more usual price. The next writer has both similar and divergent views...
LM



CHEAP HIGH QUALITY

Dear Lloyd,
As your magazine shows, there are many high quality games available, far too many to buy all of them. If software houses reduced the price of their games more would be bought. This has already been done with **Mastertronic**, and their games aren't particularly high quality. High quality games at cheap prices would sell enough to make up for the smaller profit. This would also decrease pirating, because a games player would rather buy a cheap game than wait a month for a copy.
Mark Ramshaw, Peterlee, Co Durham.

Top 10, Gnasher and Bullseye. We will be reviewing their games soon (since it was mentioned earlier in this column, I've heard that the entire CRASH purchasing department has staggered to his feet and tottered drunkenly across the Ludlow Bullring to Preedy's to buy the cassettes - the power of the press!
LM

WRONG!!!

Dear Sir,
I am writing to you on two points. The first of which is about your 'Cheats Corner' in May 1984 CRASH. You displayed a few different ways of cheating on *Manic Miner*, which I think is completely **WRONG!!!**

The author of *Manic Miner* obviously took a lot of trouble over producing a game like that. Now cheats like you are getting on the scene and producing **ENDLESS LIVES!** This in my opinion is entirely destroying the concept of the game. Why not just play the game properly and depend on your own skills?

My second point is on the spelling in CRASH. It's **disgusting!!!** I was reading Cheats Corner when I read, 'When the sheet you want appears on screen, release the key and start playing.' Can't you do any better than that? If not then get someone who can.

Richard Speigal, Eltham, London SE9.

At the risk of losing a doubtless valued reader, Richard, can I say that you are acting like a wimp! It's a bit like saying the English language is sacrosanct in the way it is spoken and written. Well it's not, the way people actually speak and write it is the English language - it's constantly changing. So, too are games. The way games are played is what they are - cheating including. Of course you should use your skill to win. But you'll notice that it's only the really good game that people want to cheat at. That's the first point. The second is that people 'like us' aren't 'getting on the scene and producing endless lives'. Good grief, Richard, where have you been recently? Within days of *Jet Set Willy* appearing people - just like you - were ringing and writing in to every computer magazine in the country with endless lives POKES and the lot. Within days, ads were appearing to rip people off by charging £1.95 for an endless life POKE. We didn't publish any POKES on either *Manic Miner* or *Jet Set Willy* for a set period in order to give the game a chance, and many other publications did so before CRASH did.

As to the spelling (not that one again!) just sit down and read a few of the better class Sundays and count up all the 'disgusting spelling' errors. They **do** happen, and often when there's one there'll be another close by because if one has been overlooked when it comes to correcting then it's likely any others nearby will also be overlooked. **AND LET'S GET ONE THING STRAIGHT** before finally banning the subject - what we're talking about here is not disgusting spelling

- it's mis-typing, not surprising with approximately 140,000 words a month. The average novel length is 60,000 to 85,000 words, and takes several months in the typesetting and proof reading - not three weeks like CRASH takes - so there!

To end on a happier note - poetry seems to be the up and coming thing these days among games players. I thought the Moral Majority considered violent games bred violent people, but it's obviously not true. CRASH readers make great poets - well almost great...
LM



ODE TO CRASH

After buying my new Spectrum,
I've really got the blues,
There's so much Spectrum
software,
But which to choose?

I must by CRASH...

I've studied all the inlay cards
Until my eyes are sore,
There's *Manic Miner*, *Jet Set Willy*,
And hundreds, hundreds more.

Are the graphics good on *Cookie*,
Is it worth the price,
Shall I become addicted,
Or only play it twice?

The answer's in CRASH...

My problems are all answered,
I know which games to buy,
I'm getting value for my money,
And all my scores are high,

THANKS TO CRASH!

Simon Horobin (11), Wimborne,
Dorset.



There you go, that's all for this
month, 'rucks' more letters next
issue - I must dash, the
Mastertronic have arrived!
LM

SINCLAIR, ATARI
COMMODORE

COMPUTER REPAIRS
by the
SPECIALISTS



Walkers
COMPUTER SERVICE
AND REPAIRS

Telephone: (021) 643 5474
Telegrams: -
Shuplog Birmingham
Telex: 537124 TWSLEGG G

WALKERS will repair your MICRO quickly
and efficiently.

Services available to suit the Customers
requirements include "one-off" repairs and
Quotations.

Most Repairs will be in the range
£15 to £30
subject to machine

FOR INFORMATION
PHONE 021-643 5474

CALL IN AT
58 OXFORD STREET, BIRMINGHAM, B5 5NX

OR SEND S.A.E. FOR DETAILS

SUPER-LEAGUE

| | W | D | L | F | A | Pts |
|---------------|----|---|---|----|----|-----|
| 1 Ipswich T. | 16 | 6 | 5 | 41 | 20 | 54 |
| 2 Liverpool | 16 | 5 | 5 | 61 | 31 | 53 |
| 3 Notts City | 13 | 9 | 5 | 45 | 19 | 48 |
| 4 Birmingham | | | | | | |
| 5 West Ham | | | | | | |
| 6 Southampton | | | | | | |
| 7 Leicester | | | | | | |
| 8 Notts. | | | | | | |
| 9 Wolves | | | | | | |
| 10 Tottenham | | | | | | |
| 11 Sunderland | | | | | | |
| 12 Q.P.A. | | | | | | |
| 13 Watford | | | | | | |
| 14 Everton | | | | | | |
| 15 Norwich | | | | | | |
| 16 Coventry | | | | | | |
| 17 Aston U. | | | | | | |
| 18 Man. Uni. | | | | | | |
| 19 Luton T. | | | | | | |
| 20 U.B.A. | | | | | | |
| 21 Arsenal | | | | | | |
| 22 Stoke C. | | | | | | |

For use on
48K
SPECTRUM



- Full 22-team League
- 42-match season

- Full 11-a-side match action
- Scale 90-minute game
- On-screen commentary showing current score, name of player in possession, time played
- Individual player skills

- League table and results on screen and printer
- Save season to date on tape

**Be a top tactician and
watch your team play in
the safety of your home!**

**Also form any league of
22 teams and pick
your own players!**

£6.50
(inc. p.&p.)

Order direct from
CROSS SOFTWARE(C),
36 Langford Crescent,
Barnet, Herts, EN4 9EH

Also available from selected stores
in the London area (including
Virgin Megastore, Oxford Street)



AD ASTRA

TO THE STARS!
FOR THE 48K SPECTRUM FROM GARGOYLE GAMES

“SPACE IS DEEPER THAN YOU THINK . . .”

ONLY £5.95 EACH

**100% MACHINE CODE
 ARCADE ACTION, FEATURING
 GARGOYLE'S STUNNING
 CARTOON GRAPHICS.**

AVAILABLE AT SELECTED
 RETAILERS OR SEND COUPON
 DIRECT TO GARGOYLE.



**DEALER ENQUIRIES WELCOME.
 TEL: 021-236 2593.**

PLEASE RUSH ME _____ COPY/COPIES OF AD ASTRA,
 I ENCLOSE CHEQUE/P.O. FOR £ _____ @ £5.95 EACH
 POST AND PACKAGING FREE

Send this coupon to:
**GARGOYLE GAMES,
 4 NORTH WESTERN ARCADE,
 BIRMINGHAM,
 B2 5LH.**



CRASH THROUGH THE LOTHLORIEN WORD SEARCH TO WIN A MICROMOUSE CASSETTE.



Micromouse - The great educational arcade game from M C Lothlorien. Fight off the software bugs with Datakill and help Micromouse de-bug his programs. Fight through the levels to the highest score.

HOW TO ENTER

Study this list of titles from the Lothlorien Range. We've hidden 24 of them in the word search jumble. Words can run horizontally, vertically or diagonally and forwards or backwards.

To start you off we've ringed 'PARAS'. There will be 100 Micromouse cassettes for the first 100 correct entries. Prizes will be awarded strictly in order of receipt, so send your entry as soon as you think you've found all the titles.

- | | | |
|---------------------|---------------------|--------------------|
| BATTLEZONE 2000 | HYPERBLASTER | SPECIAL OPERATIONS |
| BEDLAMBLASTER | JOHNNY REB | ROMAN EMPIRE |
| BEEBLEMANIA | MICROMOUSE | SPOOKY MANSION |
| CHOC A BLOC CHARLIE | MUMMY MUMMY | THE STOLEN LAMP |
| CONFRONTATION | PARAS | TWO GUN TURTLE |
| DIGGER | PELOPONNESIAN WAR | TYRANT OF ATHENS |
| DREADNOUGHTS | REALM OF THE UNDEAD | WARLORD |
| GRID PATROL | RED BARON | ORION |

THE LOTHLORIEN STORY

The Lothlorien story goes back to Manchester Central Boys Grammar School in the days when computers occupied half a castle and cost twice as much.

Mike Cohen, Roger Lees and Geoff Street were all boys together, but left to pursue separate careers in commerce and business.

By 1981, Mike Cohen and Roger Lees were each writing Wargame programs as a hobby interest, selling them privately and separately.

In 1982 they got together to form M C Lothlorien and launch the famous mind-stretching WARMMASTER series.

In 1983 they were joined by Geoff Street who had moved into professional programming with a major International Bank.

Now all three have specific roles in an expanding company. Mike Cohen is Managing Director, Roger Lees is director in charge of Marketing and Geoff Street is Technical Director.

Following the success of the WARMMASTER series the company moved into Arcade action with ACTIONMASTER, acquiring a reputation for high technical quality. MICROMOUSE is a typical title. It has arcade action but embodies the principles of programming in an easily

assimilable form.

Thought provocation has been part of the Lothlorien philosophy since the earliest days. And certainly the games provide players and reviewers alike with abundant food for thought.

Most action games are 100% machine code and more and more reviewers have commented on the quality of sound, smooth graphics and very attractive presentation.

More critical reviewers have welcomed originality and thought-provoking content, putting Lothlorien at the forefront in this sphere.

Now, with some 40 titles available for virtually all machines, the company has moved on to provide Adventure too, with the ADVENTURE-MASTER Series. And with a factory opening soon will be in a position to guarantee quality even with the fastest delivery.

Central to The Lothlorien Story is a belief in promotion. Originally all games were available by Mail Order but now you'll find them in most leading software outlets. Lothlorien regularly appear in the reputable Computer Titles and will soon appear on TV, when the eagerly-awaited Autumn Titles will be revealed.



RULES OF ENTRY

1. Competition is not open to employees or agents of M C Lothlorien, or their relatives.
2. No responsibility can be accepted for lost, damaged, or illegible entries.
3. Prizes will be awarded to correct entries in strict order of receipt - the sooner you post your entry, the better your chance of winning!
4. A correct solution will be published in CRASH Magazine.

NAME _____
 AGE _____
 ADDRESS _____
 POST CODE _____

Send To: M. C. Lothlorien, 56a Park Lane, Poynton, Stockport, Cheshire SK12 1RE.

LOTHLORIEN

M C Lothlorien, 56a Park Lane, Poynton, Stockport, Cheshire SK12 1RE.
 Tel: Poynton (0625) 876642.

KERRASH!

N·E·W·S

The Bubble Bursts

Imagine is dead — long live imagination.

After months of rumours and counter-rumours, the lively, publicity-seeking Liverpool software company has collapsed owing half a million pounds to its bank and creditors.

The company founded by **Mark Butler** and **David Lawson**, who originally split away from Bug-Byte, has lasted a little over a year, having attracted enormous news coverage from all the media including television. Shortly before the collapse, Imagine was claiming to be worth in the region of £30 million.

Discord

But behind the facade of software bustle, money and fast cars there has been a long history of internal discord. The earliest rumours of Imagine's instability started before Christmas when a large amount of their massive advertising bills remained unpaid. The ads had been booked by Imagine's agency, **Studio Sting** and an estimated amount of over £50,000 of advertising was unpaid when Studio Sting went into liquidation. The agency's proprietor was **Stephen Blower**, who was also a shareholder in Imagine. Blower became a victim, according to close witnesses to the Imagine in-fighting.

Another member of Imagine's staff to fall foul of the founding fathers was **Alan Maton**, who has also been at Bug-Byte. He hadn't been with Imagine for very long when he became unwillingly involved in a somewhat messy situation which was the creation of another company intended as a hidden offshoot of Imagine. When Alan was offered a more suitable partnership and the chance to run his own affairs away from the fog of the Butler/Lawson administration, he took it and **Software Projects** was formed. For months afterwards Maton was forced to retreat behind a legal shield as all manner of threats and writs were hurled in his direction by the apparently incensed Dave

Bill, and I'm not convinced we've got everything we agreed to.' He went on to explain, 'We weren't paying over money just for old stock. The idea was to invest in the new games as well, but I think something's gone wrong.'

When **Colin Stokes**, sales manager for Imagine, left the company and went to work for Alan Maton's Software Projects, he was faced with the same barrage of invective, both verbal and legal, with Imagine publishing in their *Newsletter* a whole chunk transcribed, it is claimed, from telephone conversations between Colin and Imagine's competitors in the business. Colin had come under the heading of 'unreliable' in the Butler/Lawson cannon and so his office phones had been bugged.



Colin Stokes — his phones were bugged.

Mounting Debts

Imagine had over expanded. It was booking its own ads in the magazines and not paying for them. Debts were mounting with tape duplication firms and remaining unpaid. A few weeks ago, being pressed for payment, Imagine sent out a duplicated letter to creditors saying that they were expecting to receive £250,000 within 21 days and would settle all accounts at that time. The deadline came and went.

Sale of Titles

Then the news was announced that Imagine had concluded a deal with London-based **Beau Jolly** to sell the marketing rights of all their current titles. Beau Jolly's Managing Director, **Colin Ashby**, told CRASH, 'To be honest, I'm not very happy with the deal. We're still waiting for the master tape of PC



Mark Butler and David Lawson from more innocent days.

Bill, and I'm not convinced we've got everything we agreed to.' He went on to explain, 'We weren't paying over money just for old stock. The idea was to invest in the new games as well, but I think something's gone wrong.'

The news of the sale alarmed many creditors, CRASH included. It is impossible to get money from a company without assets, and hadn't it just sold the assets? It is a criminal offence to sell assets of a company which is insolvent. CRASH put this to Colin Ashby. He said, 'What a revelation. I hadn't thought of that.'

The new games Ashby was referring to are the 'mega-games' *Psychopocalypse* and *Bandersnatch*. He told us, 'I've been trying to get Lawson, Butler or Heatherington for weeks because we thought we were doing the new games as well in this deal. But I can't get hold of them.'

No wonder, Messrs Butler, Lawson and Heatherington were not in the country — at least, according to **Bruce Everiss**, Operations Controller of Imagine, David Lawson and Ian Heatherington were in San Francisco trying to raise more money.

The Collapse

On the 28th June the CRASH offices heard that *Personal Computer Games* had issued a writ against Imagine for their debts. A call to Imagine was fobbed off with the comment by **Dave Leon**, financial controller, not to pay attention to silly rumours. When pressed he did admit that a writ had been served. We then called Bruce Everiss and the confusion began to clear. When asked what was happening at Imagine Bruce replied shortly, 'The company is up shit street. There has been no proper financial control. Not even a VAT return has been done.'

Responsibility for Imagine's financial affairs belongs to **Ian Heatherington**, who together with Butler and Lawson form the Imagine triumvirate. According to Bruce Everiss, when Heatherington saw the state he had allowed things to reach, he formed a personal survival plan together with Dave

Lawson. The idea was to form a new company and gradually transfer the assets of Imagine into it. This would normally be subject to legal scrutiny by any creditors, but according to Everiss they had the best lawyers money could buy and the whole is water tight.



'The company is up shit street' — Bruce Everiss, Operations Controller.

The new company is called **Finchspeed** and its directors are Mark Butler, David Lawson and Ian Heatherington. Finchspeed is expected to take about 20 staff from Imagine, the minimum needed to produce the mega-games which Colin Ashby thought Beau Jolly would be marketing.

The future of Imagine was in doubt by the time the PCG writ landed on them. With all the assets stripped and with debts of half a million pounds, Bruce Everiss was left to find jobs for 60 people. 'It makes me sick,' he said to CRASH, 'to think that the people who have worked so hard to make the wealth of Imagine have been left high and dry while the directors of the company have stripped it bare and got away scot free. They did everything to line their own pockets.'

So will we see the mega-games? A member of the advertisement department at *Personal Computer Games* has told us that should anyone having anything at all to do with Finchspeed or any of its directors approach them for advertising space they would be told where to go. Bruce Everiss is more pragmatic about Finchspeed's chances. 'They have a lot of money,' he says. 'If they go round paying in advance for their ads, who will refuse them?' ●

Trashed by Trashman

In what may prove yet to be the most dangerous precedent ever set by a member of the software community, **New Generation** launched its new series of *The Complete Machine Code Tutor* for the Spectrum (48K), CBM 64, BBC and Atari computers. This was done in quite a clever way, since the computer press are not noted for dashing out to launches of educational software. New Gen arranged a competition for the various editors of computer magazines to battle over a game of *Trashman*—the winning editor to take a weekend in Paris for two. This fiendish ploy was obviously designed to get an ear for the new program as well as setting editor at editor's throat and starting an intermeicine war between the magazines!

In the end, after a lot of nail biting, the winner was **Peter Green**, editor of *Computing Today* who scored 9187 points. He beat **Chris Anderson**, editor of *Personal Computer Games* by only 45 points. Chris had played in the first round at the same time as the erstwhile *CRASH* editor did his bit. **Tony Heatherington** of *Personal Computer World* came third with 3138

CRASH was bravely represented by none other than **Roger Kean**, who despite the disadvantage of a damaged joystick at his regular morning practice, managed to come somewhere after that with two thousand and... something!

The holiday was handed over accompanied by a suitable round of booing from the other unimpressed magazines.



Rod Evans, Managing Director of New Generation presents Peter Green with champagne and details of the weekend in Paris.



A study in serious concentration – Eugene Lacey of Computer & Video Games (his Mum always told him he'd be a dustman when he grew up).

Machine Code Tutor

This is New Generation's first excursion into the 'educational' software market. It is aimed to give the BASIC programmer a step by step guide to learning machine code programming. The Spectrum version contains two cassettes with over 100K of data. 33 lessons follow exercises together with a comprehensive booklet. New Generation claim that the user may experiment without fear of crashing the program and that the high standard assembler in the system ensures fast error trapping and correction. *The Machine Code Tutor* retails at **£14.95** and will be subjected to a *CRASH* review soon.

Cheaper Software

The British software industry has been a little alarmed by the spate of cheap software around recently. Warwick Leisure's **Pulsonic** range at £2.99 and the **Mastertronic** programs at only £1.99 have obviously given cause for alarm. Despite general public calls for lower prices, many software houses feel that it is no longer economically feasible to produce really complicated games at such low prices.

Nevertheless a number of well-known companies are preparing to do just that and lower prices. Mike Cohen of **Lothlorien** says that the market is changing, opening up so that it is possible to sell a particular type of game at around the £3 mark without seriously affecting the high quality game for which Briatin has become known at the higher prices. Lothlorien are certainly considering a range of much lower priced games, and a cartel of other software houses are expected to announce low-priced ranges of games before much longer.

Software house **C.C.S.** have also gone onto the lower price range, kicking off with two games in the new 'Charlie Charlie Sugar' range. Priced at £2.99 both games are for the 48K Spectrum. *Dix Mille* is described as a traditional French dice game which can be enjoyed by all age groups. *Whodunnit* is an investigative game for up to four players and is a computer version of the famous board game Cluedo. *Whodunnit* looks like one we have already seen released by a company called Placet, but the new

Jump Challenge

Eddie Kid, the motor-cycle stunt ace, is soon to be a computer game! Software producers **Martech** are launching a game called *Jump Challenge* on the Spectrum (48K) and the CBM 64 this month. Eddie, whose astounding bike jump of 190 feet is a world record, has been closely involved with the game's programmers for several months, claim Martech. They say the result is a unique, highly realistic game which challenges the player to try and match Eddie Kidd's skill, timing, control and sheer courage in leaping over increasingly difficult and dangerous obstacles. Well, we'll soon see.

In the meantime, if the real things appeal as much as the game, Martech say that Eddie Kidd will be making personal appearances on the Martech stand at major computer fairs over the next few months.

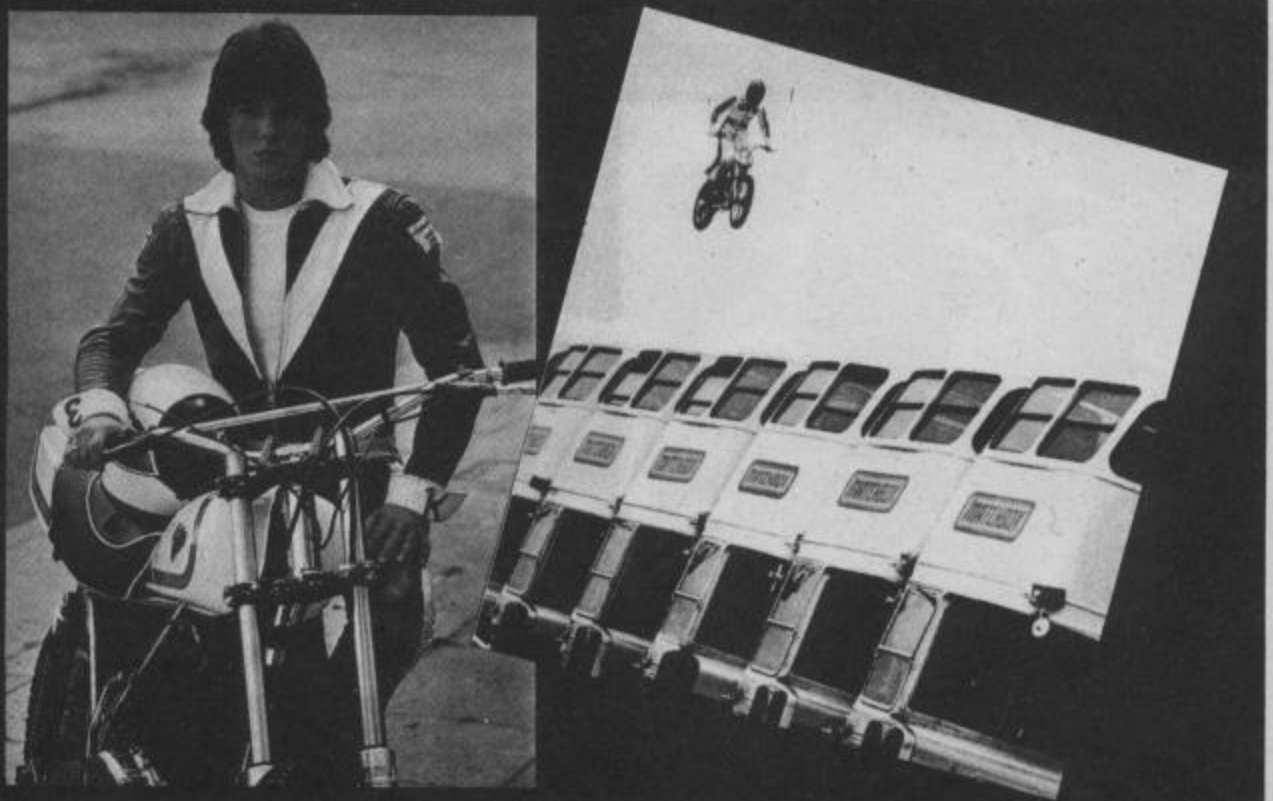

version has been rewritten.

C.C.S. say that the new range is designed to encourage impulse buying and is accordingly priced within the average teenager's pocket money allowance. A lot of software houses have obviously noted **Mastertronic's** success when placed next to the till a quick impulse buys out of the change from a main game purchase. The question remains – at half the price, on average, of games which have been carefully developed, are these cheapies really worth the money? We'll be taking a look at the Charlie Charlie Sugars next issue.

Anti-copycat Cartel

Software houses **PSS, CRL, Anirog, Silversoft, Interceptor, Microdeal** and **Visions** have joined forces in an attempt to stamp out home copying. The action being taken is the threatened withdrawal of all advertising support from any journal carrying advertisements for tape or disc copiers. **Gary Mays** of **PSS** said, 'There shouldn't be the

need for such devices. We offer a replacement tape or disc should either fail to load, and I would have thought this was sufficient.'

Marlboro Clubman

On a somewhat lighter note **PSS** have a hardware success on their hands it seems. It comes in the form of 23 year old **Kevin Bowes** and his motor cycle. Kevin, a printer by trade, started racing motorbikes as a hobby. He progressed well against his local Coventry rivals and came to the attention of **PSS** who pledged their sponsorship support for 1984.

It's been repaid well. After an early victory in a pre-championship warm up race at Snetterton during March, Kevin has gone from strength to strength, qualifying for the **Marlboro Clubman's Championship**, where he is currently lying 5th in the overall Championship table.

The Moth of Magra

After an extensive advertising campaign over the Christmas period and then endless delays in its release, **Carnell's Wrath of Magra** adventure seems to have bitten the dust owing to the fact that **Carnell Software** has gone into liquidation. At the time of writing, the company has called a meeting of creditors to sort the situation out, but it seems unlikely that **Carnell** will survive in any recognisable form.

The fate of the *Wrath of Magra* is also in some doubt. There were rumours that the program had been partly financed by the software distributors **Websters**, but phone calls to **Websters** resulted in blanks being drawn – they had never heard of it. It is possible that another software house may pick the program up for marketing. Advance reports from **Derek Brewster** on the game suggest that despite its mammoth length, it contains serious drawbacks including up to 10 second delays in responding to input. So for the time being it looks as though *Magra* is in mothballs – maybe forever.

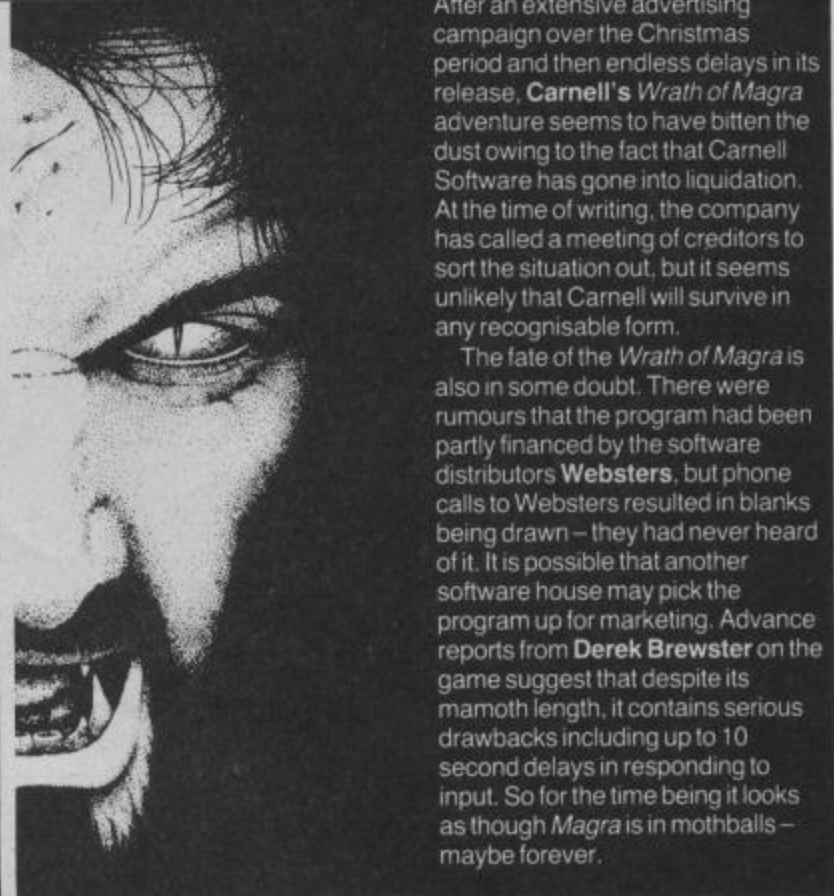

Kevin Bowes on his PSS sponsored bike.

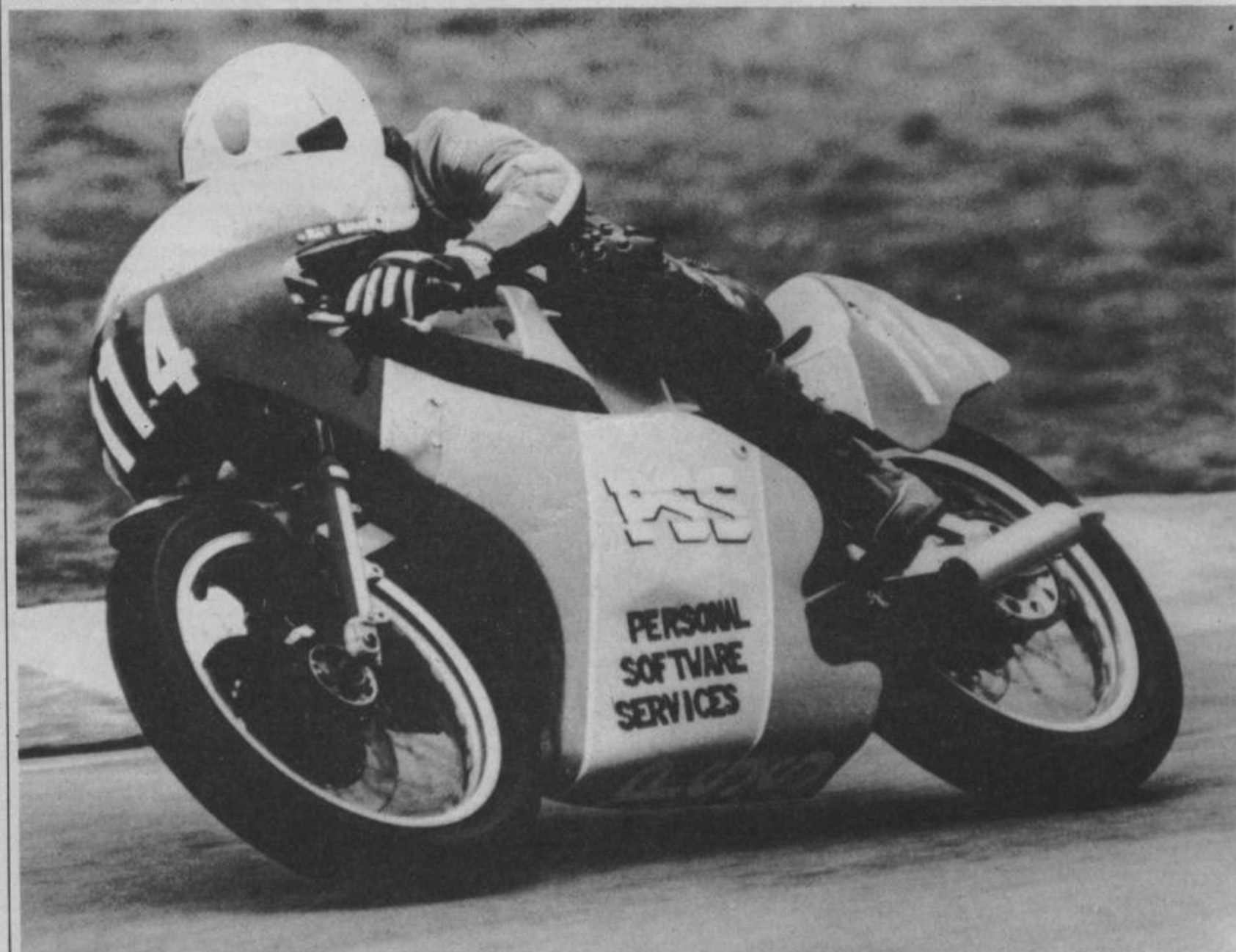



The Kelwood K-Board in place.

K-Boards

Professional keyboards for the Spectrum have become quite a business in recent months. Now **Kelwood Computer Cases** have launched their **K-Board**. Unlike most other fit-on keyboards, the Kelwood K-Board is not a complete housing for the Spectrum but an assembly which sits on top of the Spectrum's keyboard and replaces the membrane circuit. The new keyboard fits where the old one was with ribbon connectors replacing the existing ones. The keys are foil printed in red and gold and are claimed to have a fast switching time, with smooth action and a travel of less than 1mm. The keys are shrouded by a plastic moulding on top of which sits the original Spectrum key template.

The K-Board costs **£28.50** (+95p for p&p) and is available from **Kelwood Computing, Downs Row, Rotherham, S. Yorks S60 2HD**.

The Cost of Repairs

It seems to be harder to get your Spectrum repaired these days, what with reports of Sinclair themselves taking up to six months in some cases. As a result repair services have become more common. **Thomas Walker & Son Ltd.**, are one such, but in this young business Walkers are hardly new. Established in 1838, the Birmingham-based company has been innovators in the field of marine instrumentation. They hit the headlines in 1980 when they launched the world's smallest and cheapest satellite navigator to the yacht leisure industry.

The **Sat Navs**, which are a combination of receiver, computer, keyboard and display PCBs, have given the company considerable experience with the Z80 CPU which is the basis of the Spectrum. It seemed natural to move into home computer repairs. Their repair service now includes the Atari and Commodore computers as well as the Sinclair machines.

The services offered by **Walkers Computer Service and Repairs** provide for one-off repairs and

quotations direct to the customer and as a support to computer dealers who require back-up to their sales. **Thomas Walker & Son Ltd.**, are based at their works, 58 Oxford Street, Birmingham.

American Software

Cheetah Soft (*Bat Attack* and *Conquest*) has signed a deal to produce **Imagic Software** for the Spectrum. Imagic has been producing software in the United States for some time. The first two titles are *Moon Sweeper* and *Dragon Fire* and should be available on cassette soon priced at £7.95.

Cheaper Interface

Cambridge Computing have recently reduced the price of their Spectrum Programmable Joystick Interface from **£34.90 to £29.95** which includes the two independent fire button joystick. The interface

alone is reduced from £27.90 to £22.95.

At the same time the software used to program the joystick interface has been extensively rewritten, say Cambridge. It is now fully microdrive compatible and additionally can record the key combinations for up to 250 separate games (48K version).

New Representation

With *Full Throttle*, **Micromega** look set for another 3D hit, but **Neil Hooper** says it may be one of the last 3D games they do. There is another on the stocks, a cockpit view game with a sequence of events such as landing on a planet, walking in space, getting into a crawler, shooting aliens, returning to the ship and blasting off, but that is likely to be the last strictly 3D game **Micromega** produces. He says, 'We're looking at a new representation for video games. There are lots of ideas floating about here at the moment. It's all quite exciting!'

Spanish Action

In last month's News Input we reported on some games from a Spanish software house. Some of their Spectrum programs have already been reviewed by us and would have appeared in this issue, but we have been asked to hold them back. The games and all their documentation were in Spanish, but an English software house (undisclosed at this time) has entered into a marketing deal with the Spanish company, **Ventamatic**, to market the games here in Britain. At present new English inlays and English text graphics are being designed. So we'll be reviewing them as soon as they are ready.

48K SPECTRUM £5.50
COMMODORE 64 £6.50

SPLAT!



48K SPECTRUM CHALLENGE
FROM INCENTIVE SOFTWARE LTD

48K SPECTRUM £5.50



48K SPECTRUM £5.50
BBC MODEL B £6.50

1984

A GAME OF
GOVERNMENT MANAGEMENT



48K SPECTRUM £5.50

TEMPLE of VRAN



48K SPECTRUM £5.50



AVAILABLE FROM LEADING DEALERS EVERYWHERE

OR DIRECT FROM
Incentive Software Ltd, 54 London St,
Reading RG1 4SQ (0734) 591678

Star Trader

Producer: Bug-Byte
Memory required: 48K
Retail price: £6.95
Language: machine code

The game requires the skills of a shrewd trader and a fast trigger, it claims at the start of the instructions in the two-part load of this new Bug-Byte game. However, for those not so keen on the space arcade action, it's possible to avoid confrontation by not arming your cargo ship with a laser, although it means almost certainly having to pay a tribute to marauding pirates. Mercifully, *Star Trader* has short and to the point instructions on the screen, so there's no need of a ZX Printer, Eidetic memory or Pitman shorthand skills.

The game falls essentially into two distinct parts, the strategy buying and selling bit on the various planets, and the space travel bits where you are likely to meet and be engaged in combat by pirates after your cargo. The trading takes place over eight planets and involves eight commodities - grain, guns, tools, timber, wine, clothing, oil and gold. A picture on the left of the screen shows the space port which, rather like Holiday Inns, looks the same whichever planet you are on. Should you enter a trading establishment it is replaced by a large picture of the trader in question who, rather like Holiday Inn managers, looks the same whichever shop on whichever planet you are on or in. To be fair, the traders have different coloured eyes, hair,



Like any good Holiday Inn manager, the traders tend to look alike...

sometimes have moustaches, sometimes hats, but the identikit pic feeling persists!

At a spaceport you may opt to go in (to take off) and will be asked which destination you wish. You may be refused permission if you are medically

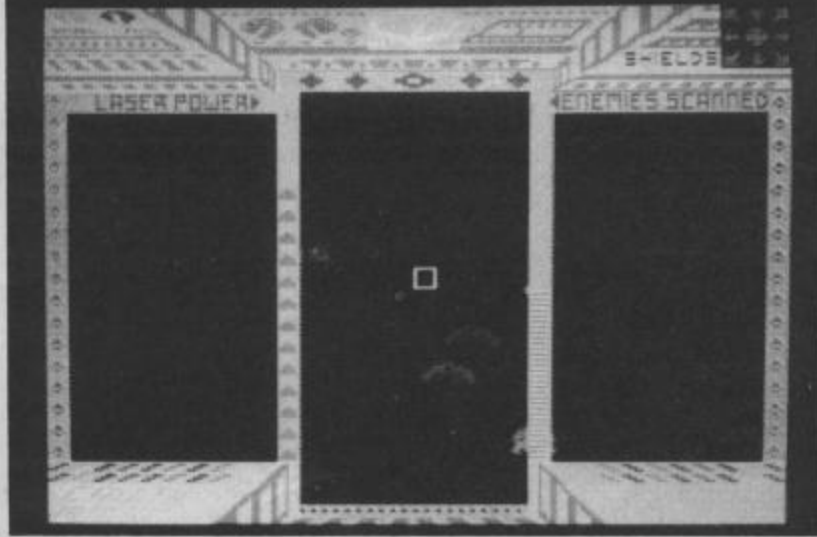

Space pirates threaten your cargo in *Star Trader*.

unfit, a situation remedied by resting and eating good food! When you arrive at your destination you can list your goods in the customs hall, declare all, nothing or part of them or bribe the customs officer and part with appropriate money accordingly.

If you don't enter the spaceport the options open are to go to a farm, a gunsmith's, a tool shop, sawmill, wine merchant's, jeweller's, pub, hotel or general store. It is from the general store that you can buy the essential lasers and power packs with which to defend your ship from pirates. In a shop you can buy or sell, but it's worth keeping an eye on the economic status report which will tell you what buying and selling prices are at all the planets in all commodities. The other thing to keep an eye on is the time of day as the shops and spaceports tend to close at night and for lunch - pubs and hotels also have appropriate opening times.

The arcade sequences take place in space and the screen shows a viewscreen in which planets can be seen moving in simulated 3D. If you have no laser on board, then pirate attacks and tributes are merely reported, but if you are armed then the enemy ships can be seen swooping in on you, firing. Laser power and ship's shield strength run down quickly and if you don't want the game to end it is worth surrendering before you are killed as the pirates are fairly sensible chaps and usually leave you with something to trade with at your destination. The object of the game, obviously, is to get rich!

CRITICISM

● 'The graphics, though there aren't many on the trader part of the game, are well drawn as are the ones in the arcade part. There is very little sound except when you are shooting aliens and what there is of it is rather poor. This game is fun if you like trading games and is fun to play with friends. The added bonus

of the arcade game is a good idea after trading goods all day (how peaceful!) It gives people like me (psychopathic killers) a chance of knocking off the odd pirate. I didn't think it was a very good game overall but it may appeal to the more peaceful members of the computer gaming universe.'

● 'This is a game that is playable but will take a long time to play if you don't get killed off by pirates. Graphics are very detailed and colourful, but where has the sound disappeared to? I found whizzing off to planets to sell goods quite fun although the in between arcade sequences seem a little long and drawn out. Keyboard input is usually one touch. Quite a playable game, if you've got the time.'

● 'Star Trader represents an advance over the space trading game like Quicksilver's old *Trader*, in as much as the latter was a linear game with a start and a definite end. In this game you can keep playing until your money runs out. In general I thought the content was a little lacking with most problems arising from becoming hungry at inconvenient moments or concluding your trading to find the spaceport closed. The graphics overall are quite good, and the arcade sequence is very nice although your ship does look rather antiquated (Dan Dare-ish). The 3D effect is simple but works, although I couldn't figure out why they had gone to the trouble of showing planets moving towards you (you can steer) but which didn't need avoiding as they do it all by themselves. It seems a bit pointless. Nothing really startling or new here, but a user-friendly program which I enjoyed reasonably well.'

COMMENTS

Control keys: cursors
Joystick: Kempston, ZX 2, AGF, Protek
Keyboard play: mostly single input, responsive on arcade sequences
Use of colour: good

Graphics: generally good, large and detailed
Sound: very poor
Skill levels: 1
Originality: the trading concept is hardly new, nor the combination with arcade action, but this game does have a fresh look and is well implemented.
General rating: above average.

| | |
|----------------------------|-----|
| Use of computer | 73% |
| Graphics | 67% |
| Playability | 69% |
| Getting started | 68% |
| Addictive qualities | 63% |
| Value for money | 57% |
| Overall | 66% |

Clerky

Producer: Unique
Memory required: 48K
Retail price: £5.99
Language: machine code
Author: Simon Harrison & Jonathon Carter

Clerky is to filing cabinets what *Psst* was to blooming flowers - at least in concept. All *Clerky* wants to do is GOTO his favourite pub but before he can do that he must GOSUB first. The subroutine in *Clerky's* life is that he is a filing clerk and a low wage earner. His boss won't let him go until all the filing is done, and he won't earn enough money to afford a drink unless he works hard. Life is made worse by the flying inkpots which try to spill ink all over his shirt front and the publican (being a fustpot) won't let him into the pub if he's besplattered with ink stains. Another problem is the mad typist in the next room who keeps throwing rubbers at him.

On screen, there is a large five-drawer filing cabinet filling the left side of the screen. *Clerky* floats around in the blue void left, collecting the sheets of paper which are dropped randomly from six slots along the top. The object is simple, catch a paper and run it over to the cabinet. It doesn't matter which drawer you aim for, as soon as you touch any part of the cabinet one of the drawers is filled. When all five are full you progress to the next screen. On the first, there are only two inkpots, and another is added with each progression. The inkpots dart around all over the playing area, killing *Clerky* off if one hits him. The rubbers enter from the right



Empty filing cabinets waiting to be filled, and Clerky with his mind on the pub.

and bounce slowly along to the left at the bottom of the screen.

Despite indications to the contrary in the scenario, all the game takes place in the office, none of it in the pub. Points are scored for catching a letter and double for filing it.

CRITICISM

● 'Clerky is by no means a sophisticated computer game, but it is quite playable for all that. There is a start up screen of Clerky leaving home and walking to the office block he works in, with the lift going up to the top floor, but otherwise all the action takes place within the confines of his office and after a bit it seems to get claustrophobic. The characters are reasonably large but the inkpots look as though they kill you off before they really touch you. By the time there are four pots flying around on the screen the game gets very hard. However, there isn't enough variation or overall excitement for it to have any lasting appeal.'

● 'The idea behind this game is very simple – even idiot-proof, although the game progresses from easy to impossible depending on how many inkpots are flying through the air. The playability of the game is reduced because you can get killed by an inkpot even though it doesn't touch you. This seems strange as they move about with a smooth action. Keyboard responses are very good and well positioned but there is no sign of user-definable keys as mentioned in the insert. Generally I found the game unplayable and of a very primitive nature.'

● 'Graphics are large but un-colourful and the black inkpots don't show up very well against the dark blue background. The letters float down very nicely. Clerky himself is quite nicely drawn and animated and the way he catches letters on his shoulder is amusing, but overall the game contains little to inspire, quickly becomes very re-

petitive and progressively unplayable.

COMMENTS

Control keys: Q/A up/down, O/P left/right
Joystick: Kempston, DK Tronics, AGF, Protek
Keyboard play: good positions and responsive
Use of colour: below average
Graphics: uninteresting
Sound: good tunes but generally average in game
Skill levels: 1
Lives: 5
Originality: the idea is neat but the implementation is limited
General rating: not very addictive and below average.

| | |
|---------------------|-----|
| Use of computer | 60% |
| Graphics | 40% |
| Playability | 38% |
| Getting started | 68% |
| Addictive qualities | 20% |
| Value for money | 30% |
| Overall | 43% |

Buriabeast

Producer: **Kerian UK**
 Memory required: **48K**
 Retail price: **£5.50**
 Language: **machine code**
 Author: **Matthew Dowell**

Buriabeast is described as introducing a new plateau in graphics and sound. What the insert doesn't tell you is that this is a straightforward 'Panic' type game, and with the amount of versions available already, you could say the game type plateaued out a long while ago. You are the sole surviving member of the human race and it has fallen to you to defend the world from hordes of marauding mutant KENS (as in 'D'ye Ken John Peel') and your only tool is a shovel. Quite honestly, if I was the sole surviving member of the human race, I think I would leave the world to the marauding Kens.

Thus described, the game is

quite traditional – five platforms, several ladders of varying lengths, holes to be dug or filled to trap monsters which, if they escape from a trap, get more vicious. The novel feature is the Buriabeast (is he a Ken or not?) – a man-sized blue monster who has to fall through three holes to die. The game is played against a falling oxygen level.

CRITICISM

● 'The graphics are quite colourful and detailed, especially the beast himself. I think this is also the first 'Panic' I have seen where you can dig holes right beside ladders – indeed, even on top of them. The monsters are quite intelligent, although the higher level monsters



● 'I think it's a bit late in the day to bring out yet another version of this ancient arcade game, unless, of course, it's spectacular. *Buriabeast* isn't really spectacular in content, graphics or sound. That said, it's a perfectly playable 'Panic', and if you haven't got one and want one,

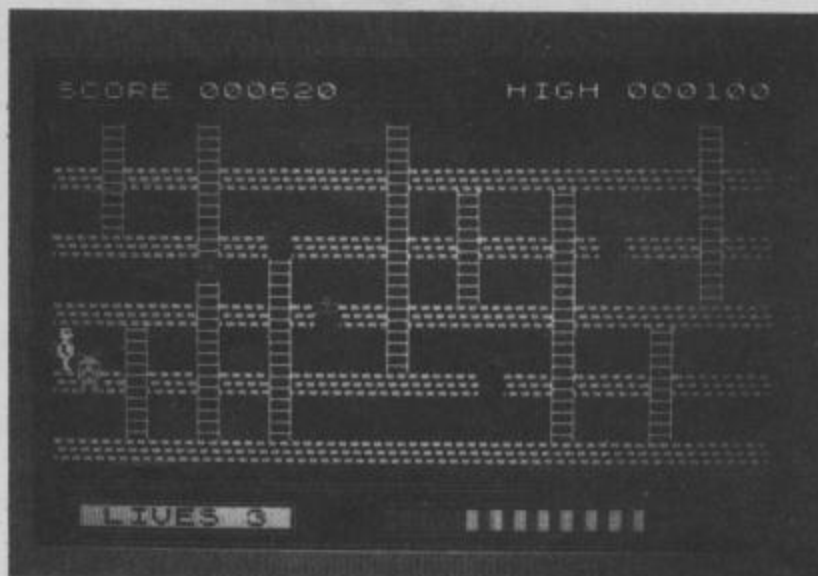

Don't panic whatever you do, and keep a sharp eye out for the Buriabeast.

almost always oblige by falling into your holes. The tunes are quite good. Graphics move by the block and are quite small except for the man and the beast, both of which move well. Overall a fairly neat 'Panic' type game, but still not the best on the market.'

● 'I seriously doubt the wisdom of anyone bringing out yet another 'Panic' game, when there are already so many on the market. As to the new plateau in sound and graphics – well the tunes are quite nice but nothing special, and the same can be said of the graphics. Your man moves quite well, and has a nice touch – when he jumps through a hole, he bends his legs quite realistically on landing. When you lose a life you reappear immediately at a random position on the base platform, usually away from the monsters – no time to relax! By no means the worst, nor the best 'Panic' game for the Spectrum.'

then this is probably as good a buy as most.'

COMMENTS

Control keys: Q/A up/down, O/P left/right, D/F dig/fill
Joystick: none
Keyboard play: responsive
Use of colour: average
Graphics: average
Sound: above average with good tunes
Skill levels: 3 speeds
Lives: 3
Originality: hardly any (close to original)
General rating: an average 'Panic' game.

| | |
|---------------------|-----|
| Use of computer | 58% |
| Graphics | 56% |
| Playability | 59% |
| Getting started | 48% |
| Addictive qualities | 52% |
| Value for money | 50% |
| Overall | 54% |

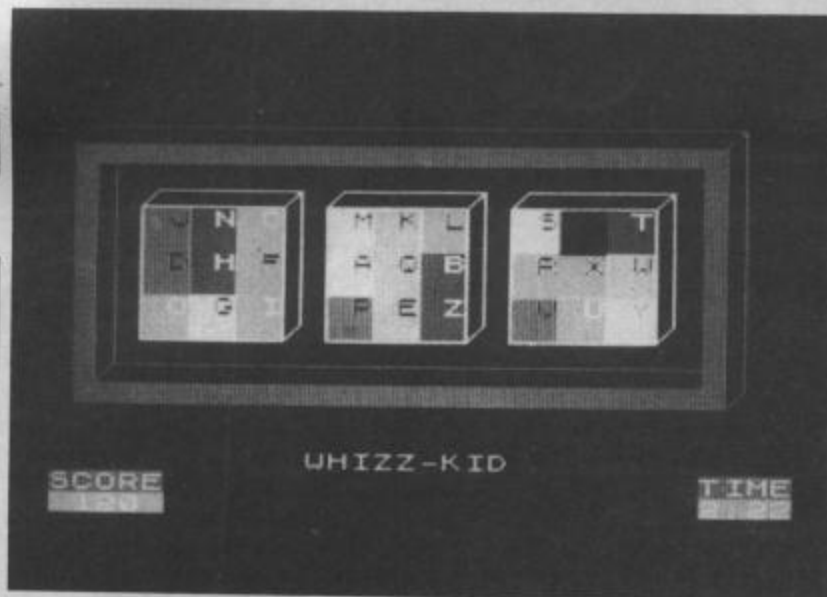

Whizz Kid

Producer: **Unique**
 Memory required: **16K**
 Retail price: **£5.99**
 Language: **BASIC**
 Author: **Phillip Carlin**

Whizz Kid is a puzzle game. It is really a computer version of those flat plastic cases containing lettered blocks that may be slid around, always one less than available squares. In *Whizz Kid* you are presented with three squares containing nine spaces – a total of 27 in all between them. With the 26 letters of the alphabet, that leaves one blank square. The object is to take the randomly sorted letters and move them around to finish with a configuration which takes you correctly through the alphabet arranged A, B, C on the top line of the left hand block, D, E, F on the next and so on, with the black square left between M and N on the middle row of the middle block.

Letters are moved by using the cursor keys and 0 to change from block to block. The less moves made, the higher your score, but the game is played against the clock with you setting the limit up to a maximum of nine minutes.

CRITICISM

● 'This is one of those simple looking games that proves to be a real brain teaser and will probably while away many an hour for those keen on letter puzzles. I found the moving of the letters a bit confusing at first and kept thinking that the old fashioned hold it in the hand version was much easier. But once you get the hang of it, the game proves quite enjoyable. Definitely a limited market for *Whizz Kid*, but worth it for puzzle enthusiasts.'

● 'I don't think this sort of game works particularly well on the computer. With something like a *Rubic Cube* you can revolve it in your hands and solve problems visually, physically, but

once on the computer the physical aspect is removed and often you forget what it was you had planned to do next by the time you come to do it. This game is made even more difficult by the slow response from the keyboard and also you can't move the letters about as freely as you would be able if it were really in your hand. Colour is used well but the so-called 'three-dimensional colour-coded grid system' is only 3D because a few lines have been added to the sides of the main blocks – not very convincing and anyway, 3D has nothing whatever to do with this game.'

COMMENTS

Control keys: cursors
Joystick: AGF, Protek
Keyboard play: unresponsive
Use of colour: reasonable
Graphics: very simple of necessity
Sound: only simple beeps
Skill levels: self-selected against the clock
General rating: a game with limited appeal.

| | |
|---------------------|-----|
| Use of computer | 41% |
| Graphics | N/A |
| Playability | 45% |
| Getting started | 58% |
| Addictive qualities | 38% |
| Value for money | 43% |
| Overall | 45% |

Death Chess 5000

Producer: **Artic Computing**
 Memory required: **48K**
 Retail price: **£6.95**
 Language: **machine code**
 Author: **Anthony Adam**

Artic have made claims in the past to being the producers of the best computer chess games for the Spectrum – it's obviously a matter for argument! *Death Chess 5000* is a novel depar-

ture from the chess format and certainly no ordinary chess game as it incorporates arcade sequences within the framework of normal chess.

For a start off the chess board, although traditional, has quite different looking pieces. Pawns are represented by tanks, kings and queens resemble lethal looking missile combinations, bishops look like high powered science fiction wind surfers, only knights and rooks are instantly recognisable. In all respects the strategy and rules of chess apply. But what makes *Death Chess 5000* really different is that when you challenge the computer's pieces or vice

the ghosts. Knight takes knight: hit the enemy horsemen before they reach your edge of the screen. Rook takes rook: scale a tower avoiding the falling barrels of oil. Queen takes queen: navigate the star trench and hit the enemy flagship. Piece takes different piece: shoot through the galactic barrier to hit the opposing ship.

Additionally it is possible to select a normal game of chess without the arcade sequences. On either game there are seven levels of play from 0 to 6. The easiest level replies in 2 seconds, level 4 in five minutes and levels 5 and 6 play a strong game and take a long time.

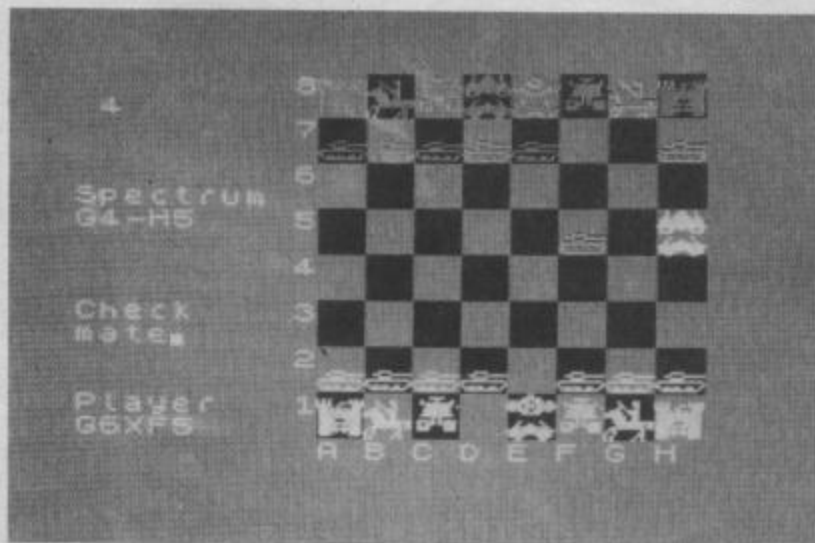

Unusual pieces in *Death Chess*.

versa the screen cuts to an arcade sequence. Winner of the arcade game retains status quo on the board. So, if you move to take a computer operated piece, before you can you must fight it out. The computer may win, in which case you will lose your challenge piece instead. There are six different games. Pawn takes pawn: you must drive your tank forward to save the city whilst avoiding the bombs raining down from an overflying helicopter. Bishop takes bishop: escape from the vaults of the enemy avoiding

Input is with the traditional chess notation. In the straightforward chess mode *Death Chess* will recommend a move if desired. Castling is allowed, and capturing en passant by pawns. Games may be saved or sent to hard copy if you have a printer.

CRITICISM

● 'Chess is a natural for the computer and I have enjoyed many games, many versions,

Rescue the city and save your piece, just one of the many arcade treats.



so I was very dubious when I loaded *Death Chess 5000*. My suspicions deepened when I saw the pieces. Chess boards on computers naturally tend to be small and novel piece design can be confusing. On top of that, would a game of chess interrupted by arcade sequences be a travesty? Well the answer is no. I haven't had as much fun in a long while in fact. On the chess side, *Death Chess* is a perfectly good game and a few minutes play gets one used to the odd looking pieces. All the arcade sequences are well done. In fact plunging into the trench is a better looking game than Rabbit's *Death Star*. I can highly recommend this version of chess to anyone who not only likes a serious chess game but is also looking for a new angle on the game.'

● 'After seeing the screen load I felt that this could not be an ordinary chess game. I was right. The arcade bits are pretty good, as good as you could expect from a multi-game package such as this. The combat idea is refreshingly different from traditional chess; so that if your strategy is not up to scratch you can make up for it with arcade skill. Problem is that the reverse is also true of course. Overall, a nice change from chess, but I don't think it will get to world tournament level!'

● 'As soon as you start playing you can see why the traditional chess pieces have been redesigned. The chess graphics are well defined and easy to see with a definite shape. Board colour combinations are very good (green and white pieces

on blue and black). The graphics in the game sequences are large, detailed and smooth. The trench sequence has an effective use of shadow under your ship. Most of the game ideas are good, some good enough to be games on their own. Artic couldn't do much to improve this game, except perhaps by really having knights jousting and tanks firing missiles for real on the playing board.'

COMMENTS

Control keys: chess—alphanumeric input, Q-T/A-G up/down, O/P left/right and bottom row to fire

Joystick: ZX2

Keyboard play: responsive
Use of colour: generally quite good

Graphics: well detailed and recognisable, generally very large

Sound: not much

Skill levels: 7

Originality: chess isn't exactly original, but this version is very different

General rating: for both serious and non-serious chess players, very good value and generally recommended.

| | |
|---------------------|-----|
| Use of computer | 70% |
| Graphics | 72% |
| Playability | 70% |
| Getting started | 67% |
| Addictive qualities | 64% |
| Value for money | 70% |
| Overall | 69% |

Auf Wiedersehen Pet

Producer: **Tynesoft**
Memory required: **48K**
Retail price: **£5.95**
Language: **machine code**
Author: **R. Carr**

Based on the telly series, this new game features the hero Oz, a Geordie 'brickie' working in Germany with such famous international locations as Dusseldorf. It is a three-screen arcade game. In the first Oz must lay as many bricks as possible under instruction from 'Herr Fuhrer' whilst avoiding the watchful 'Eric's' and falling trowles. He must also avoid laying any bricks in a place where there

are none underneath. Should he reach the top a cement bonus is added. This screen takes the form of a brick rampart with the bare scaffolding grided above it, dotted with Eric faces. Oz may move in four directions, laying bricks in the manner of a 'Painter' game behind him.

The second screen features the favourite pastime of Oz — drinking in the local bierkeller. The bar is represented by a green brick square. You start off with two tables topped by bier glasses. Oz must drink the bier without hitting the table or the multiplying bar maids. Success leads to another bout with one more table added and more madchen to avoid.



One of the most realistic loading screens yet — here comes Oz.

The third screen, a kind of bonus screen, sees Oz weaving his drunken way home. The route is beset with lamp posts, police cars and security men — none of which must be hit. This would prove easy, even for a drunken Oz, were it not for a power failure which blanks out the street lamps and everything else with it. After a good look at the scene you must memorise the route and guide Oz through safely without bumping into anything.

Between each screen there is a little graphics representation of the coming scene with wry Geordie comments on living in Germany.

CRITICISM

● 'When loading *Auf Wiedersehen Pet* you'll see one of the best loading screens ever because it shows a very recognisable picture of Oz, your favourite brickie from Geordie Land. The graphics are neat and very well drawn. The three different screens are really three different games, which adds to the value immensely. Each screen has its own particular tune and if you know the tunes you'll find that they fit the screen. The game is nicely done and the three screens are neat little games and you can't



The most complete, compulsive and entertaining football management game ever!
*4 divisions *FA Cup *European Cup *European Cup-Winners' Cup *Replays *Promotion/Relegation *Transfers *Suspensions *Injuries *Substitutes *Name team *Team selection *Name players *Choose/change team formation *Weekly league tables *Fixtures/Results table *Reserve squad *Spy on other clubs *Minute-by-minute goal facts *Goal kings feature.

IF WE DON'T DESPATCH YOUR ORDER ON THE DAY WE RECEIVE IT, YOU CAN HAVE THE GAME FREE!

PEAKSOFT, 48 QUEEN STREET, BALDERTON, NEWARK, NOTTS. Tel: 0636 705230
Rush me *The Boss* for my 48K Spectrum. I enclose a cheque or PO for £6.95.

Name

Address

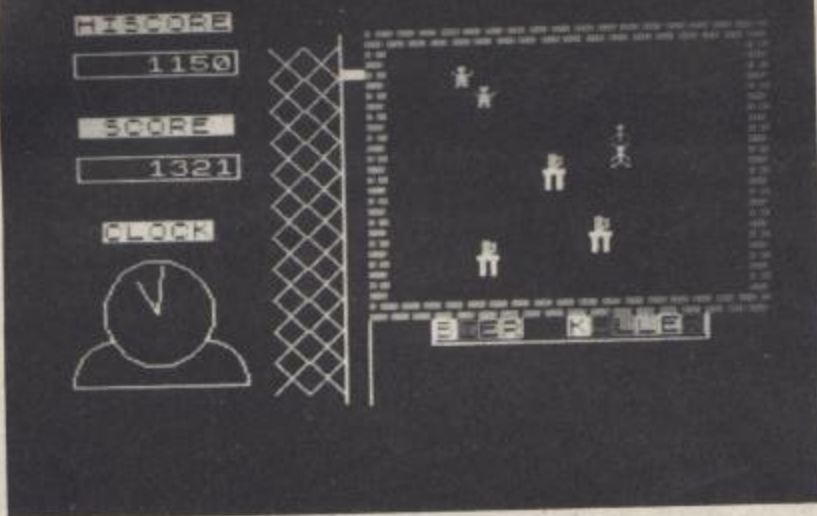

Second screen - watch out for tables and bar madchen.

really argue whether or not you've hit something because this isn't a fast arcade game. This game is definitely worth considering, especially if you want something to play together with your friends. A nice touch would've been more keyboard and joystick options. All in all, a nice game which is worth a look.'

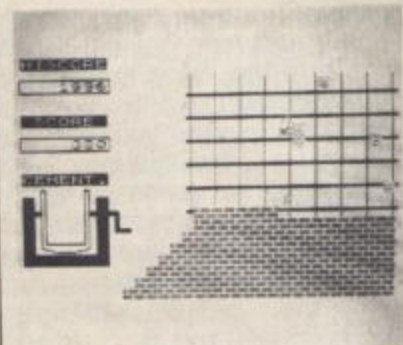

First screen and the Erics are watching as you pile up bricks.

● 'This game improves a bit with the playing, each screen getting harder (except for the third which gets easier) each time round, and very much harder each time if you complete it. In other words you play each one, one after the other continuously, but if you actually complete one in each round, you get to do it again, and again. The result can be quite addictive for a while, although I doubt I shall bother with it again. The graphics are rather primitive, although Oz is a pretty lively stick figure - it's a pity the control responses are so sluggish.'

● 'Although this is based on the TV series, I wouldn't state that as being a buying point. The scenario relates to the series but only very vaguely really. The content of this game isn't really high at all. Tunes are quite good at first but tend to get on your nerves after a fair while as do the in-between screen sequences. Keyboard response is not really up to today's standards, but then again, it isn't a real arcade type game. The third screen is the most irritating as it takes time to slot in all the lamps, cars etc., but worse still,

takes even longer to black them out again. I don't know whether this is a serious bug in the program, but I think it crashed on the second screen on reaching 50 beer pots. My score was 39,228 points - the beer pots began appearing one after the other, slowing down considerably in their appearance as it reach the 40s. The fiftieth appeared - and I'm still eagerly awaiting either the fifty-first or for the game to commence. Still waiting...'

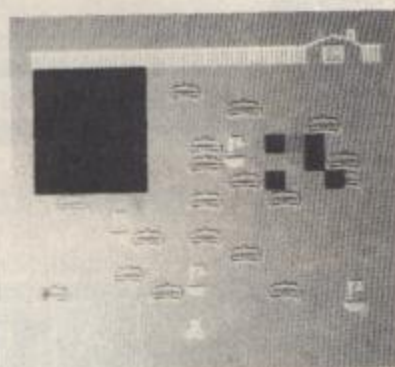

Third screen and the lights are going out all over Dusseldorf.

COMMENTS

Control keys: Z/X left/right, O/K up/down

Joystick: Kempston

Keyboard play: slow to respond

Use of colour: good

Graphics: average

Sound: good tunes, otherwise below average

Skill levels: 1 with progressive difficulty

Lives: 3

Screens: 3 games screens

Originality: overall quite original, although each game type is not uncommon on its own

General rating: mixed opinions from fair to good.

| | |
|---------------------|-----|
| Use of computer | 45% |
| Graphics | 49% |
| Playability | 60% |
| Getting started | 70% |
| Addictive qualities | 50% |
| Value for money | 49% |
| Overall | 54% |

Reviews

Omadan Attack

Producer: Avalon

Memory required: 48K

Retail price:

Language: machine code and Basic

Author: M. L. Knights

Omadan Attack is a space shoot em up in the tradition of Crystal's *Cyberzone*. The type of game where you have to shoot away the thick forcefield protecting a ship which is firing at you, before you can blow it up.

The mothership - a sort of yellow Tie Fighter shape, is at the top of the screen, firing laser blasts downwards through its thick protective shield. Your ship moves across at the bottom of the screen firing up. To either side at the base there are laser blast suppliers as you can only fire 20 blasts before needing to refuel. Additionally, your ship is unable to destroy the mothership once it's exposed, so you must call up a more powerful cannon to do the job. This cannon is no use for getting rid of the powerful forcefield however. The cannon will appear immediately below wherever your ship is placed at the time of call-up and will vanish again after firing a shot or if you lose a life.

CRITICISM

● 'Although there have been several versions of this type of game before it is still quite addictive as an idea. Sadly this program does nothing to add to previous games as it has primitive block graphics. The forcefield is just a group of pale blue character squares, three thick and about ten long. When you

shoot at it, a block disappears each time. Nothing like the lovely effect in *Cyber Zone*. It may have been wonderful two years ago, but not today.'

● 'I couldn't get on with this at all. An element of playability appears to have been attempted by giving you only 20 laser blasts before refuelling is necessary, but as this adds no risk and does not detract from a time limit, it seems to be pointless as an addition to the game. Also, the mothership's blasts sometimes destroy you when they haven't really touched you. Poor graphics and use of colour, and overall a poor game.'

● 'The packaging on this game is very simple, just a pale card with text on it, so no one can complain that they were misled by the amazing cover. Just as well, because what's inside isn't really worth bothering with.'

COMMENTS

Control keys: 1/2 left/right, 8 = call up cannon 7 = fire cannon, 0 = fire laser

Joystick: none

Keyboard play: responsive

Use of colour: poor

Graphics: fast but small and very primitive

Sound: good

Skill levels: 1

Lives: 4

Screens: based on an old game idea with a few new additions that seem to have little point

Originality: poor.

| | |
|---------------------|-----|
| Use of computer | 48% |
| Graphics | 25% |
| Playability | 43% |
| Getting started | 55% |
| Addictive qualities | 46% |
| Value for money | 34% |
| Overall | 42% |

The mothership gets in an accurate shot on your laser base. The moth-eaten block near the top is the forcefield.

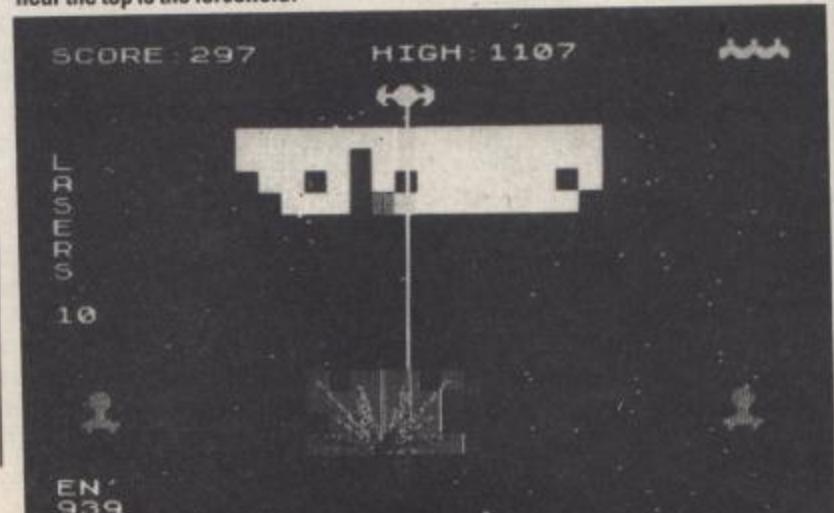

KOSMIC KANGA



KOSMIC KANGA, a multi-screen, amazing, arcade standard original action game. Featuring superbly animated graphics and packed full of arcade features. Help **KANGA** find his space ship so he can return home to his planet. Leap about buildings, trees, clouds etc., pick up bonuses and throw boxing gloves at the enemies.

Keyboard or most joystick. **48K SPECTRUM** for most other Computers soon.



Tutankhamun

48K Spectrum

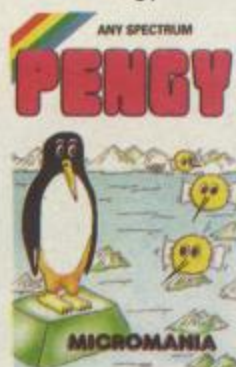

Pengy

16K/48K Spectrum



Invasion Force

48K Spectrum plus stack SLR

ONLY £5.95 EACH

Available from most good software retailers, If your local software retailer is out of stock, send cheque/P.O. to Micromania, 14 Lower Hill Rd., Epsom, Surrey, KT19 8LT., and we will send your order by first class post free.

MICROMANIA

DEALERS: PHONE MICRODEALER UK 0727 34351 OR MICROMANIA (03727)20152

Available on the
COMMODORE 64
TRASHMAN £7.95 • 3D TUNNEL £7.95 • ESCAPE £7.95
Exclusively from
QUICKSILVA
QUICKSILVA MAIL ORDER
P.O. Box 6, Wimborne, Dorset BH21 7PY.
Tel: (0202) 891744.

Trashman

**It's the fun game of
the year – Trashman.**

From the moment you sit down to play you'll be thrilled by this exciting, original, laugh a minute game.

Your job may look easy to the rest of the world, but you know the hazards – speeding cars and pavement cyclists can both shake you up. Let's face it cars can be fatal.

But if that isn't enough you've got the other problems of vicious dogs, the after effects of overeating in the transport cafe or one too many in the boozier.

Not only will you be gripped by the action you'll be amazed and amused by the high quality graphics.

With seven levels of play featuring three attempts to finish the game (assuming you are not run over by a car) Trashman will provide even the most experienced games player with a thrilling challenge. 1 or 2 player option, Hall of Fame and joystick compatibility* ensure this game has all the best arcade features.

Trashman is available **NOW** for the 48K Spectrum. Ask for it today at your local computer store!

Only £5.95

*Kempston, Sinclair Interface 2,
Protek or equivalent.*



New Generation products are sold as readily on their terms of trade and conditions of sale.

Available from selected branches of:

WHSMITH

John Menzies

WOOLWORTH

spectrum



And all good computer stores.

**New
Generation
Software**

FREE POST,
Bath BA2 4TD
Tel: 0225 316924.

Spectrealm

Producer: **Runesoft**
 Memory required: **48K**
 Retail price: **£6.95**
 Language: **BASIC**
 Author: **Jon A. Slack**

The author of this game may be **Slack**, but he obviously allows no **slouching**, for the average Spectrian (inhabitants of Spectrealm) have to work very hard to stay alive in this strategy game. It may be played against the computer or a second player. The object is to survive one hundred years as Governor of Spectria. From humble beginnings in a land only 200 miles square, a population of 1,000 and with only £1,000 in the bank and 5,000 sacks of grain, you must expand into a megapower.

This is no dictatorship. Every five years the population will go to the polls to vote. Elections are shown with your votes mounting up alongside those of your rival. How you do at the polls will obviously depend on your performance measured against your previous election promises.

planting corn seed and with the weather. A meteorological harvest forecast appears as a bar code for each month, showing the success of the harvest.

There are no graphics in the game, only text and simple bar codes. The rather luxurious looking 'leather' insert surrounds a comprehensive sheet of playing instructions and game objectives.

CRITICISM

● 'Spectrealm is a game that is much more fun with two players than with one, but I did find it extremely addictive when playing on my own. Ruling my own country gave me quite a good sense of satisfaction and achievement – something that I've rarely found with most other strategy games. The game is not totally varied, but the odd war adds a climax now and then and the voting is always exciting because it's constantly changing. Overall one of the best simulations I've ever played, and one of the most addictive. If you like this sort of game you'll love Spectrealm – and even if you don't like the sort of game, you'll probably enjoy this one.'

are conducted in nail-biting terse despatches from the front, and elections are even more edge of the seat stuff, especially when playing in two. On these occasions the player who has been in power for the past five years must match his performance against the (often) rash promises of the player attempting to become governor. So it can develop into a real power struggle. Definitely one of the most entertaining rule-a-country games yet. Addictive isn't a word that normally applies to strategy games – perhaps this is the first such.'

COMMENTS

Control keys: general input
 Responses: very good

Use of colour: practical
Graphics: text only
Sound: limited
Skill levels: 1
Features: 1 or 2 player games
Originality: in essence a standard type of strategy but with more interactive elements than usual
General rating: very good and worth its higher price

| | |
|---------------------|-----|
| Use of computer | 73% |
| Graphics | N/A |
| Playability | 75% |
| Getting started | 80% |
| Addictive qualities | 74% |
| Value for money | 68% |
| Overall | 74% |

War of the Worlds

Producer: **CRL**
 Memory required: **48K**
 Retail price: **£7.95**
 Language: **machine code**
 Author: **Nigel Taylor**

Ogilvy the astronomer always sounded like a bit of a twit, but at least he went down in history by coining the famous lines that almost became the chant of a generation in **Jeff Wayne's** musical adaptation of the H. G. Wells novel *War of the Worlds*.

'The chances of anything coming from Mars are a million to one,' he said.

The chances of anything coming from Mars are a million to one – but still they come!

War of the Worlds is described as a graphics arcade/adventure strategy. In a superficial way it resembles *Valhalla* visually, in as much as 'you' are animated. The adventure ele-

ment comes in that you are supposed to move in directions when possible, the arcade in that you are frequently opposed by the Martian fighting machines which will blast you to death unless you can run from them.

The game starts on Horsell Common, Surrey, where the still cooling cylinder has landed. The top unscrews and a Martian fighting machine emerges, firing its death beam. You are given three options – make a run for it, hide in the bushes, or stand very still. Hiding is the best bet and you will escape. Pressing a key results in your finding yourself on a nearby road in the company of an artillery man. You can move via the cursor keys and the landscape of fields and houses scrolls past. Each screen section ends and allows you to walk to the edge before cutting to the next section. Occasionally roads lead north or south. Any direction may be hazardous if you encounter a fighting machine. On running away from one you tend to get lost and wander

One of the excellent title screens in War of the Worlds.

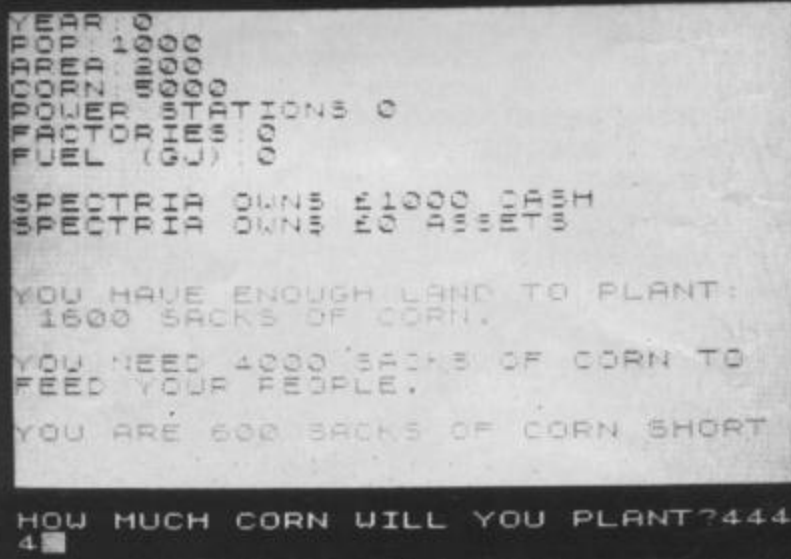
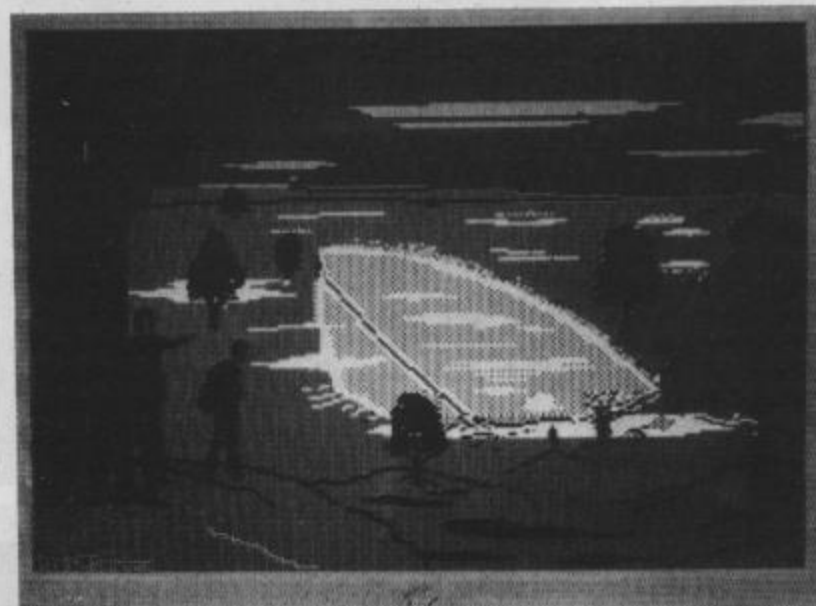

Elements which affect the game include feeding the population, buying capital plant like power stations and factories, and all this in turn depends on having enough population to cope. Factories and so on may be bought on the world market, but wars crop up from time to time which not only increase your population and land area (if you win), but may add enormously to your installations at little cost. Produce from agriculture and factories may be exported to make more money if there is a surplus to requirements, but in the early stages the main preoccupation is with

● 'This is one strategy game that I could keep playing. I really enjoyed it. It isn't graphically very exciting but the game just seems to keep growing on me – like the corn! I am normally no fan of such games – this is an exception.'

● 'There is no winning limit in Spectrealm, you just keep going until the population throw you out or you wear out! There's plenty to contend with but unlike, say, Dictator, your options once used don't run out on you, which makes it a much more realistic simulation. There are a number of neat touches – wars

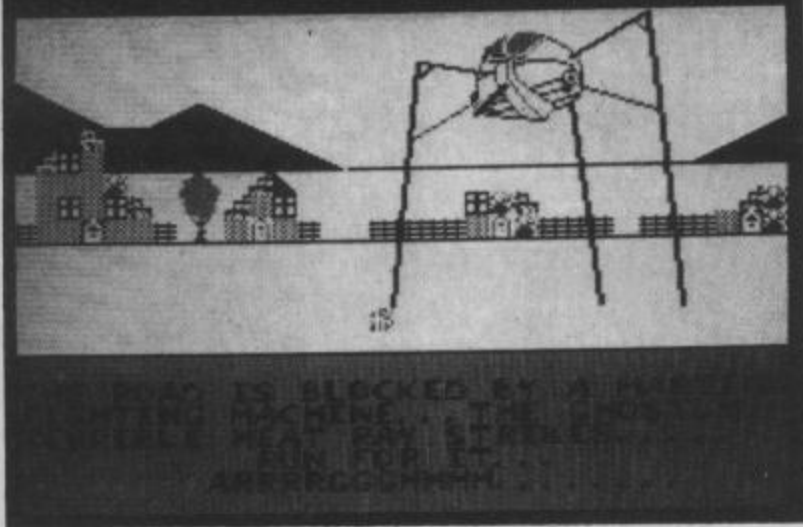

Another Martian fighting machine blasts you into the dreaded set up mode.

around for a while. Companions are inevitably turned to ash by Martians if you manage to escape from a Martian.

You are searching for your fiancée, Carrie, and the object of the game is to reach the main Martian encampment by visiting six specific locations. These must be visited in the correct sequence and on the correct days. As a result of this, the game plays to its own time scale, beginning on Monday morning. If night falls, you must find a house to shelter in or die of the cold. Only houses with open doors may be entered. Food and drink must also be discovered, although you start with three bottles (unspecified contents) and three loaves. More bottles and loaves are dotted around the streets (again, reminiscent of *Valhalla*). Getting caught in the panicking crowds fleeing London is not very pleasant and may lead to your untimely death by trampling. As the game progresses the Martian Redweed spreads its baleful, bloody influence, draining your strength if you get entangled in it.

The *Hobbit* held clues which were to be gleaned from Tolkien's book – *War of the Worlds* relies on your knowledge of Jeff Wayne's album, and occasionally musical clues are provided. To help you visit the six locations correctly, they are featured in the game in their correct order in Jeff Wayne's musical version of *War of the Worlds*.

CRITICISM

● 'Looking through the review copies for this issue, *War of the Worlds* stood out due to its artistic cover and larger sized cassette case. Loading it revealed a lengthy introduction to *War of the Worlds* with a few instructions included. It looked great. The second part loaded after a long wait, the action started – text and a menu selection with a time limit. Graphics finally appeared on the screen – stick men, primitive looking houses and poor use of colour. Your man moved quite slowly for a stick man and the key

responses were very slow. The game itself has too many random features in it and totally lacks content.'

● 'Jeff Wayne's musical version was a long-lived album hit and with his name firmly attached to this computer version with its excellent cover, I thought it was really going to be something, but sadly it lets the player down all the way along the line. The least of the problems being the Spectrum's inability to match the strength of the original soundtrack! The two-part load is irritating these days, and any atmosphere which the words from the musical version might have conjured up for the player are well and truly lost by the time the long second load is completed (this can be got around for second time playing by typing in LOAD "L2" and playing tape as normal). The two title screens are really very good so the let down when the game graphics commence is all the bigger. At a first glance *Valhalla* comes to mind, but the detail and animation of these stick figures is quite primitive and the backgrounds aren't as good either. As to the game itself, is wandering up and down endless roads all identical except for a caption below the playing area informing you of where you are, very much fun? The thrill of encountering a Martian fighting machine is dulled by their absolute similarity and the arcade effect ruined by the inevitability of having to avoid them with incredibly slow, jerky movements that take no account of a player's skill. Very sadly, a total failure in my estimation.'

● 'Any sympathy I had with *War of the Worlds* evaporated after being killed a few times and having to wade through a key press, read the summary of failure, key press, slow tune over title, key press, jolly whizzing things, repeat setting up phrases about the cylinder landing and reselect to hide in the bushes. Should you miss your cue at this point it all happens over again. I timed it this whole procedure from the moment of

death takes 1 minute and 23 seconds. After an estimated seven deaths within the first hour, this means I spent almost ten minutes solidly watching the repeat routine. The game itself does play like an adventure – you can forget the arcade bit – but it really revolves around walking along streets, picking up bottles of wine and loaves of bread, finding a house for the night, and staying clear of Martians and panicking crowds. Since you have no control over these random elements there is little if any strategy involved either. I really had expected much, much more.'

COMMENTS

Control keys: cursors

Joystick: Protek, AGF

Keyboard play: poor

Use of colour: very good title screens, limited during play

Graphics: ditto

Sound: generally poor in game without Currah, reasonable tunes

Skill levels: 1

Features: Currah Microspeech compatible

Originality: based on a 'novel' idea but the implementation spoils any effect

General rating: below average and, at its price, poor value for money.

| | |
|----------------------------|-----|
| Use of computer | 45% |
| Graphics | 53% |
| Playability | 38% |
| Getting started | 59% |
| Addictive qualities | 37% |
| Value for money | 42% |
| Overall | 46% |

United

Producer: C.C.S.

Memory required: 48K

Retail price: £6.00

Language: BASIC

Author: T. Mendham & A. Parr

There are now a number of football management simulations around of which the most famous is undoubtedly Addictive's *Football Manager*, a consistent and long-lived chart topper. C.C.S. have always been noted for their strategy and management games – can they beat Addictive? The game is played in a somewhat different manner, although the ultimate

objective is much the same – take your Fourth Division team to the top to win the League Championship.

Once loaded, the program offers a choice of buying, selling, renaming and training players, choosing a team, a disciplinary status, list of fixtures, display League table, scouting and a save facility. You start with no players and £6,500,000 to spend. A table of 20 available players is called up which numbers them, tells you whether they are young, prime, mature or old, whether they are goalkeepers, sweepers, defenders, midfield or forwards. Each is shown with a strength rating depending on their level of skill, and then their price. Apprentices cost nothing and play their first four games at a level of 0 before becoming classed as young players with a level of 2.

Morally speaking, your selected team is all clean at the start, that is, they haven't been disciplined. Before a match, you may decide how hard you want them to play from 0 (Clean) to 10 (Dirty). The harder the selected level the better your team's chances are, but you run the risk of penalisation and even a player being suspended.

To prevent unbalanced teams the total strength rating of any group within the team, ie. Goalie plus sweeper, defence, midfield, forwards, must not exceed three times the strength of any other.

Having selected a team, decided on how dirty they are to play, and in which of your team you wish your allocated advan-



tage strengths to be stressed, the match as selected in the fixtures may be played. In United, the graphics representation is seen from the top and the match mechanism is such that shots are shown; the object of selecting your team carefully is to ensure that you get the maximum number of shots, each of which is 'tested' against the opposing team. Shots are won when an area of your team is stronger than its complementary area in the opposition. Each shot is tested first against the sweeper (if there is one). Any shots that get past him will then be tested against the goalkeeper. These edited highlights may be watched in full with each real-time minute taking approximately 4 seconds on screen, or it may be skipped over to the result by pressing CAPS SHIFT and S together.

As each week goes by you receive value points, and the more successful you are the more VPs you win. You need these to raise cash and to be able to train members of your team, thus raising their strength status, or to go scouting, which will give you valuable insights into other teams' strengths and composition.

CRITICISM

● 'I would have to say at the start that I am fan of neither football nor football strategy games, and consequently found *United* a rather daunting prospect. I also found the allocation of **hard play** and **advantage** strengths a bit difficult to understand. Neither are all that well described in the otherwise excellent instructions on the inlay. However, having mastered that to some degree, the game began to turn out pleasant, and eventually even fun. With increasing numbers of value points it was possible to do more things and some of the built-in strategical elements began to come into play, extending the enjoyment. The match graphics are not stunning but nevertheless the tension

HOW THE RATINGS WORK

| | |
|-----------|--|
| Under 30% | a waste of time |
| 31-40% | generally poor, but may appeal to some |
| 41-50% | average |
| 51-55% | reasonable if type of game enjoyed |
| 56-60% | good on most counts |
| 61-70% | generally recommended |
| 71-80% | highly recommended |
| 81-90% | knight of the British Empire |
| Above 90% | words fail |

mounts with the minutes ticking away.'

● 'This football simulation can be summed up by saying that the strategies etc. are better than *Football Manager* and much more involved. But the actual working and graphics are worse. So choice is a matter of opinion. The game is very slow (as is the actual match). Generally I preferred *Football Manager*, but it's close enough for opinions to vary.'

COMMENTS

Control keys: general input
Responses: generally good to input although there are parts of the program which do take time
Use of colour: not much but sensible

Graphics: mainly text, match highlights very simple

Sound: restricted to entry beeps in the main

Skill levels: 1

Features: via one of the program authors it is possible to play *Postal United*, address and details on the inlay

General rating: above average on strategies, poorer on the graphics but overall an enjoyable simulation.

| | |
|---------------------|-----|
| Use of computer | 60% |
| Graphics | 30% |
| Playability | 49% |
| Getting started | 67% |
| Addictive qualities | 53% |
| Value for money | 60% |
| Overall | 53% |

Pit-Stop

Producer: **Avalon**
 Memory required: **48K**
 Retail price:
 Language: **machine code**
 Author: **M. L. Knights**

Pit-Stop is a new version of a very old and standard racing game, the sort of concentric grid game where you must drive around four lanes connected at the main compass points, avoiding chasing vehicles which travel in the opposite direction.

The object is to leave the central pit area and collect the four tools lying in the far corners, one at a time, and return them safely to the pit. There are two chasers, one running in the outer two lanes and one running in the inner two. They only

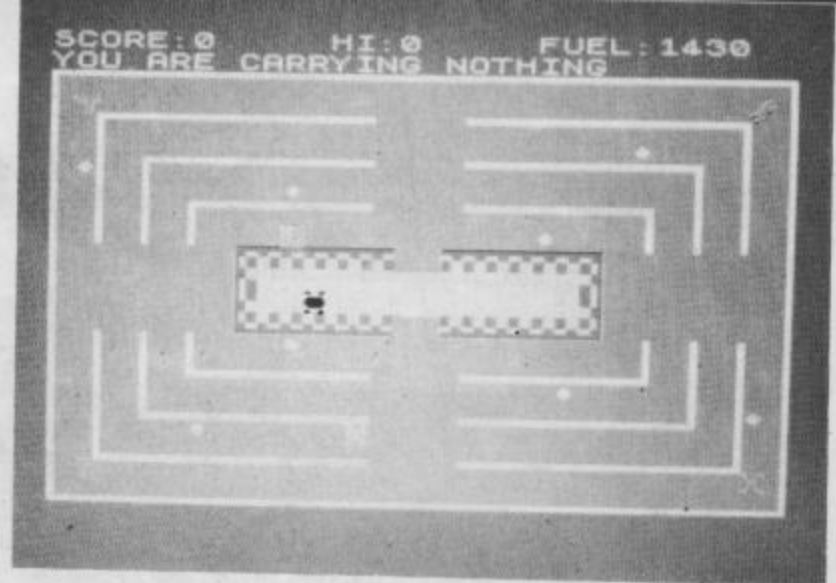

It might be best to stay in the pit in *Pit-Stop*.

change lanes at the top or bottom. Your car may change two lanes at once. Points are scored for collecting tools and for dropping them. There is a time limit imposed by fuel supply, which will be replenished if you get all four tools back.

CRITICISM

● 'This type of game is very old and out of date - no matter how many frills are added, the game is still boring. Collecting tools is a novel idea but no different to eating the more usual dots. Chaser cars always tend to get in the way (although that's the central idea of course) and make it difficult to play. The trouble with the basic idea behind this sort of game is that luck plays the bigger part. If you crash then a stupid remark appears in the centre of the screen. Colour is not really well used because the cars don't show up at all when playing from a distance. A poor, old and unaddictive game.'

● 'This is a fast type game at which some people undoubtedly get good, but can you be bothered? The programmer has chosen to have four directional lane change control which is very confusing instead of having a simple 'in' or 'out' control. If



Originality: some new frills on an old, old game
General rating: poor to fair of its type, generally poor.

| | |
|---------------------|-----|
| Use of computer | 51% |
| Graphics | 52% |
| Playability | 46% |
| Getting started | 58% |
| Addictive qualities | 43% |
| Value for money | 38% |
| Overall | 48% |

the game is out-dated, the sound track is positively ante-diluvian with that dread *Death March* tune when you lose a game. The explosion is quite effective, but overall the graphics are small one character-sized, and boring to look at, with poor use of colour. A waste of money.'



Kosmic Kanga

Producer: **Micromania**
Memory required: **48K**
Retail price: **£5.95**
Language: **machine code**
Author: **Dominic Wood**

Kosmic Kanga is an entirely novel game for the Spectrum by Dominic Wood who brought us *Tutankhamun*, *Pengy* and one of the best simple shoot em ups for the Stack Light Rifle, *Invasion Force*. All our reviewers agreed that this is not only a very original game, but also the best yet from Micromania.

At the outset, we must point out that there aren't as many screens as were suggested in our competition earlier, the main reason being that in putting the original concept together as a completed program, Micromania felt that it was getting too unwieldy and spoiling the playability.

The basic object of the game is to guide Kanga home, back to his base on the Moon. This takes him through eleven different screens; the Airport, the Desert, a bonus screen, the Ocean, Atlantis, a bonus screen, the Beach, the Country, a bonus screen, the City and finally the Moon. Each of the main screens is actually a very large playing area since they scroll from right to left for quite some time. Before each screen starts there is a status panel informing you of the nature of the enemies ahead and the objects to be collected, played to the tune of *Tie me Kangaroo Down Sport*. The bonus screens are only a screen wide, but they are designed to scroll vertically and so are quite high in total playing area.

Kanga is controlled by his jumping. He can be moved left or right as far as the scrolling screen will allow, but there is considerable manoeuvring possible by making higher or lower jumps. Points are gained by collecting objects which may be on the ground, floating on clouds or on the backs of whales in the sea, they may be on the tops of tall buildings. Some objects are dangerous,



Tie me Kosmic Kangaroo down, Sport...

like bombs, but the biggest danger comes from the various deadly objects which fly along with the screen scroll. For his protection, Kanga can do what Kangaroos have always done, hurl boxing gloves at his enemies. All the playing screens are shown in the excellent demo.

CRITICISM

● '*Kosmic Kanga* is a really original game. The graphics are very good. So too is the playability. Generally I enjoyed this game enough to consider it a contender for a game of the month. The bouncing is a little difficult to co-ordinate at first, but with a little practice it soon becomes more predictable. Graphics are varied, detailed, smooth moving, and everything goes along well in what is a very good game.'

● '*The finish on Kosmic Kanga is good - lots of small details have been used to add to playability. Each little pre-screen intro which warns you of what you are about to face, is a little gem*

in itself, fully animated bright lights effect, the tune, and all the items listed dancing in animation to it. I also liked the small Kangas at the base of the screen which tell you how many men you have left. When a new life starts the screen Kanga appears from the top down as though materialised from all his atoms, and dies in reverse - so too do the small Kangas for that 'life'. Bouncing becomes quite an art once you get the hang of it. Moving left or right only works when you touch the ground, so the skill required to get through even one screen, let alone all eleven, is quite high. The graphics are excellent, all recognisable and very well drawn. Although there is little real animation as such, this doesn't matter because of the scrolling screen. I found the game playable and fun, and very addictive, because you do want to get on and see how far you can go and what comes next (the demo invariably fails to get very far into a screen).'

● '*Micromania are right - this is a totally original game, although I am sure I have seen a game*

for another machine or something in the arcade which has a boxing kangaroo in it, but not like this one anyway. There are many good looking sections to the game each requiring its own skill level and tactics. The way that Kanga bounces is very good even though he isn't really animated. Graphics are detailed, colourful and move quickly and smoothly. A cheerful, tuneful sort of game with a certain bounce to it!

COMMENTS

Control keys: N/M left/right, increase jump = A, decrease height = Z, remaining keys on bottom row to throw a glove

Joystick: Kempston, ZX 2, Protek, AGF

Keyboard play: responsive, one reviewer thought they were all a little low down the keyboard

Use of colour: very good

Graphics: very good and varied, quite large

Sound: good tune, nice effects, not continuous

Skill levels: 1

Lives: 4

Screens: 11 with much greater playing area

Originality: highly original

General rating: a new, lively and well implemented game, playable and addictive, good value for money, highly recommended.

| | |
|---------------------|-----|
| Use of computer | 79% |
| Graphics | 87% |
| Playability | 89% |
| Getting started | 93% |
| Addictive qualities | 88% |
| Value for money | 89% |
| Overall | 88% |



Play the game right...

...with the *Intelligent Joystick Interface* from Cambridge Computing!

£29.95
JOYSTICK INTERFACE
AND TAPE COMPLETE

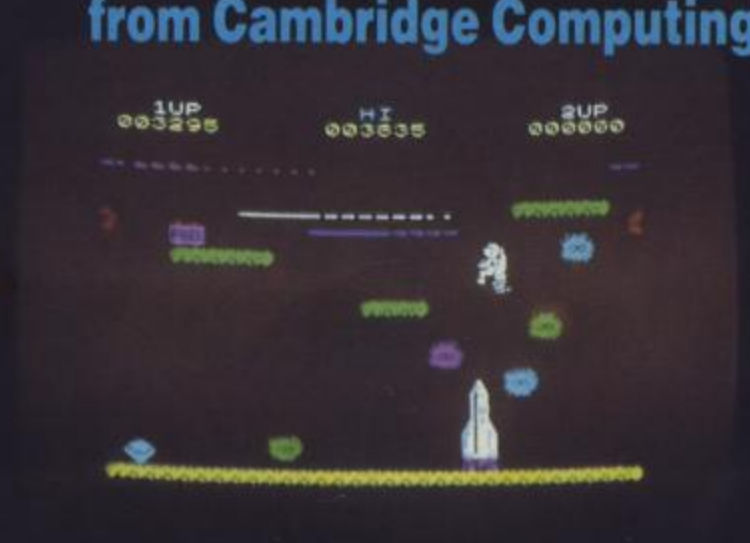

£22.95
INTERFACE AND
TAPE ONLY



Also available from
John Menzies

Interface Easy to program
● 1K on board memory ● Own rear edge connector ● Compatible with all standard joysticks
● Now Microdrive compatible

Joystick Self centring ● 8 directional microswitched action ● 2 independent fire buttons ● Standard 9 pin D connector

Tape Easy to use program enables the interface to work on **ALL** software ● Keeps a record of all your games — so you only need to program it for each game once!

CAMBRIDGE COMPUTING

1 Ditton Walk, Cambridge CB5 8QZ Telephone 0223-214451

Ring us now for details of your nearest stockist.

Name _____
Address _____

Please send me:

Joystick, Interface and Tape at £29.95
Interface and Tape at £22.95
Joystick only at £7.00
I enclose cheque/p.o.
for £ _____
made payable to
Cambridge Computing

Please allow up to 28 days for delivery

CRA

*Use your skill and judgement
and play like the professionals....*



*a truly amazing version of
the game of POOL....
Spectrum 16K/48K*

£5.95

Roger Pearce

SPECTRUM



CDS Micro Systems

Available direct from CDS Micro Systems
Send Cheque or P.O. To CDS Dept. 10, Westfield Close, Tickhill, Doncaster DN11 9LA. Tel: (0302) 744129.

(Trade enquiries welcome)

CheetahSoft



Soft we're not

FOR SPECTRUM 48K



CONQUEST

CONQUEST A tactical game which even veteran players will find both challenging and rewarding.

Mediterranean Europe is divided into grid squares. Your aim, as Emperor, is to gain 100 squares of territory as quickly as possible— at the same time dealing with Barbarian counter-attacks, plagues, civil war and rival Emperors.

5 levels of skill, plus a continuous 'Conquest' game where all the difficulty levels are thrown in together.

3D BAT ATTACK An all action, 3 dimensional maze game where you gather up blocks of gold, at the same time pitting your wits against vicious vampire bats whose only purpose in life is to locate, hunt and kill you.

4 levels of skill. At each level the game gets faster and more complicated, and the vampires more dangerous.

CheetahSoft



Soft we're not

FOR SPECTRUM 48K



3D BAT ATTACK

AFTER THESE, THE REST IS KIDS STUFF.

Are you ready for CheetahSoft?

There's only one way to find out.

But be warned: these vampire bats know a good meal when they see one. And our friend with the scythe has had years of experience...

CheetahSoft

Soft we're not



So don't play unless you're ready to play the game for real. Because you'll find there's one sure thing about CheetahSoft: Soft we're not.

£6.95 at all good stores.

Hyperblaster

Producer: **Lothlorien**
 Memory required: **48K**
 Retail price: **£5.95**
 Language: **machine code and Basic**
 Author: **Matthew Rhodes**

In the midst of a summer concerned with the deprivations of software piracy, slump and the manic drive towards originality often at the expense of playability, *Hyperblaster* comes as a welcome return to the days of games infancy. There's nothing all that original in the concept of this 'Asteroids' type game, but it is certainly a modern one rather than suffering with yesterday's graphics as so many 'throw-backs' seem to. The cassette cover even has one of those 'old fashioned' scenarios that bring tears of nostalgia to your eyes for the good old days of a year ago!

You're out in space testing the newly developed G.P.4.U. when a bunch of unpleasant Deltanoids jump your ship. Risking all, and despite demands for your return to base from control, you decide to push the ship to the edge of its conceived capabilities, and engage the unarmed Deltanoids. That's when you realise that there are more waiting beyond the range of your sensors - thousands more...

In respect of the newly developed G.P.4.U. the graphics are standard and would be recognised by any 'Asteroids' fan as a good old laser blasting triangle fitted with rotational controls and forward thrust, and possessing the ability to hyperspace - or hyperblast as Lothlorien refer to it. But the Deltanoids are a different matter. They may be unarmed and easily dealt with in screen one, but they are guided by intelligence, each wave getting worse - and there are seventeen waves to survive.

CRITICISM

● 'This is an 'Asteroids' derivative. Unlike 'Asteroids', the objects don't split up into smaller fragments when hit, but on later levels you have to hit them several times before they are destroyed. The thrust on your ship is a good one with some inertia as on the original arcade version. Overall, not a super-original game, but a pleasant

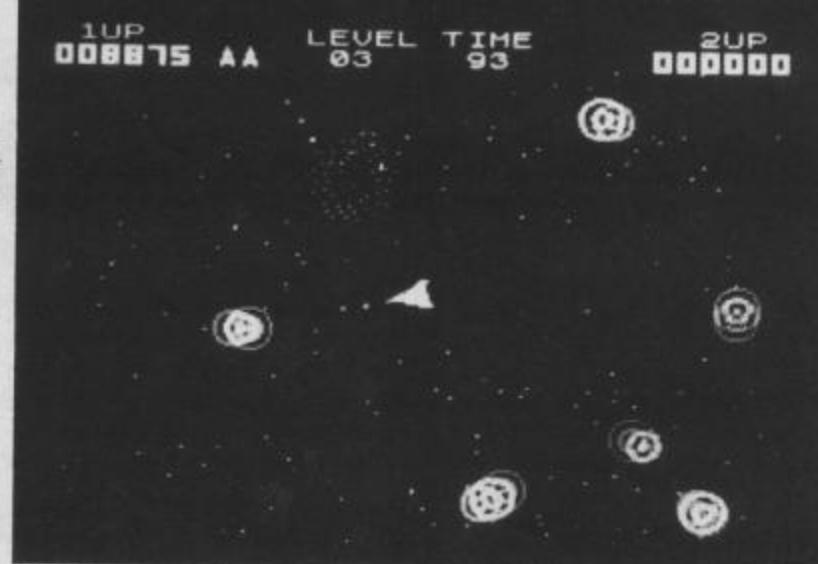

Varied and intelligent asteroids make for one of the best Spectrum shoot em ups of its type in *Hyperblaster*.

surprise and something to keep 'Asteroid' fans happy. Can't say that there was a really good Asters for the Spectrum before.'

● 'I was a bit worried when I realised this was a sort of 'Asteroids' game. Having been an avid fan of the original and played for hours on the Atari VCS version, I have always been disappointed in the many Spectrum versions. However, *Hyperblaster* really works! Your ship is nothing very special although it is larger than most rival versions which gives a better sense of position, and the thrust works well. But the asteroids are very good. Spinning planetoids, fast spinning coins, flying crinkle-cut chips and so on. Lots of variation, all detailed and nice graphics all fast and smooth moving. Also, these asteroids are intelligent, more so as you go on. Towards the end of each wave they really get vicious and must be hit several times. Perhaps the rate of fire could have been slightly better to cope with them. I enjoyed this game a lot and recommend it to anyone wanting a simple, good shoot em up.'

● 'The hyperspace facility is the best I've seen. When you press the key your ship vanishes and a large, brightly coloured square ring forms on the screen, then zooms in to the new position where you reappear. This stops all that 'where've I gone to' confusion usually associated with hyperspacing in this sort of game. The intelligence of the asteroids and the different characteristics of each wave makes for a very addictive game in the tradition of old shoot em ups. Definitely one to get.'

COMMENTS

Control keys: 1/2 rotate left/right, 6 for thrust, 7 for fire, bottom row to hyperblast
Joystick: none, but the keys are simple
Keyboard play: responsive, with good positions
Use of colour: average, but well used

Graphics: fairly large, detailed and smooth moving, good explosions
Sound: above average
Skill levels: 3 speeds
Lives: 3
Screens: 17 sheets
Features: 1 or 2-player games
Originality: obviously not original, but one of the best implementations
General rating: good to very good, addictive.

| | |
|---------------------|-----|
| Use of computer | 80% |
| Graphics | 64% |
| Playability | 70% |
| Getting started | 78% |
| Addictive qualities | 74% |
| Value for money | 69% |
| Overall | 73% |

Dartz

Producer: **Automata UK**
 Memory required: **48K**
 Retail price: **£5.00**
 Language: **machine code**
 Author: **Guy J. Brown**

There have already been several versions of Darts for the computer and while one may well wonder why on earth anyone should want to translate the noble game to the TV screen in the first place, one certainly marvels at the dottiness of doing it for the third or fourth time - until you realise who the perpetrator is! As it says on the inlay, what distinguishes this

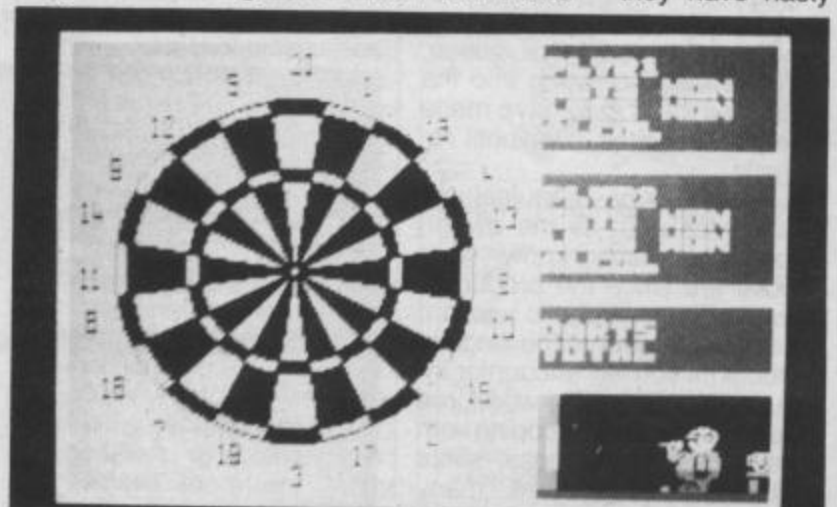

game from any of its less worthy predecessors is that, 'skill, luck and overweight drunken slob all play their vital part.' So get yourself a pint of pina colada and a packet of liver 'n' strawberry crisps and prepare to play *Dartz*.

The game may be played by one or two players with options on a 301 or 501 game. The left side of the screen shows the darts board with a flying cursor. The cursor may be stopped by the player to land in whatever segment is desired. If the dart doesn't miss or bounce off the board the screen cuts to a close up with a flying cursor moving from the bull to the edge repeatedly. Again, pressing the stop key will select the scoring band of the board, ie. bull, outer bull, double, treble or single. Any game, as proper, should end with a double.

At this point, any resemblance to any other computer darts game ends. On the right a scoreboard keeps account of each player's score; points left to get, sets and legs won - and alcohol intake! With each dart thrown the player consumes 4 milligrams of alcohol - or alcol as it says on the board. Below the scoreboard is a graphics representation of Eric (that's 'you'), a table supporting a pint behind, and the board in front. After each throw there is an action replay to show you how it went.

Adding to the hilarity are various random elements such as fans who buy you drinks and so push up the 'alcol' level in your blood, plus an increasing tendency to miss the board as you get progressively more drunk. The screen informs you from time to time of your condition, starting with giggly, through legless to paralytic. After that, things get really bad! Unless you are exceptionally lucky, alcohol poisoning is likely to kill you long before you win. Watch out for loud noises from the crowd - they have nasty

effects. And there is the obligatory free hit single on the flip side of the cassette sung by Eric and the Arras.

CRITICISM

● 'I found *Dartz* wouldn't load at first because the basic loader was in fact wrong. After rewriting it, it loaded first time. After about 5 minutes I began to wish it hadn't. The game is somewhat unplayable and not very addictive. The level of skill required to play is not very high at all. I didn't enjoy this one much. The usual 'classy' piece of 'music' on the cassette's B side is up to its usual low standard with lyrics like... I missed the board and hit the lavatory door... which just about sums up this game.'

● 'It's hard to make a criticism about *Dartz*. It's definitely a lot of fun, it's almost certainly not a game - not a real one anyway. The graphics are first rate, with loads of detail for Eric. The incidents are accurately reflected, even to the floor collapsing under him through overweight and too much drink. The darts game itself would be quite good, except that the random elements start to make it all quite irrelevant after a while. Great fun, probably worth buying for its oddity value, but certainly not addictive.'

● 'Dartz is not really a game, more a drunken simulation of a night out at the pub. Starting out

the game is quite fun to play with a few random elements adding a bit of variety to the game. After a while these random elements totally take over the game as your alcohol content rises. It's the first game I've played for a long while that doesn't require 14 fingers to control, just one will do - even your toe will do! For a company normally noted for their soberness, a real hiccup of a game!'

COMMENTS

Control keys: any key
Joystick: hic!
Keyboard play: responsive to start, increasingly erratic
Use of colour: good
Graphics: animation good in action replay, nice text characters
Sound: good where appropriate
Skill levels: starts out with 1 and gets worse
Originality: an original concept based on a relatively common simulation
General rating: a worthy piece of nonsense that isn't quite a game and will no doubt meet mixed reactions.

| | |
|---------------------|-----|
| Use of computer | 75% |
| Graphics | 59% |
| Playability | 51% |
| Getting started | 68% |
| Addictive qualities | 28% |
| Value for money | 34% |
| Overall | 53% |

Bossman

Producer: **Avalon Software**
 Memory required: **48K**
 Retail price:
 Language: **BASIC**

Bossman is a graphical strategy simulation where you run your own factory and try to make a million. New software house, **Avalon**, are venturing into the realm which **C.C.S.** have made very much their own until recently.

Your factory manufactures Robovacs and, as the owner, you presumably know what those are since the producers don't tell you - robotic vacuum cleaners no doubt. The kinds of problems you will encounter include the hiring of a workforce (and the firing of it), coping with wage demands, illness, strike threats, deciding how many

Robovacs to build and paying your stock costs and income tax. As usual with this type of game, there are various random disasters that tend to crop up such as Flu and flash floods. You can also increase the retail price of your product to take into account inflation and rising wages.

The game commences with a

Neat, clean and ideal surroundings for electronics workers don't stop them making wage demands.

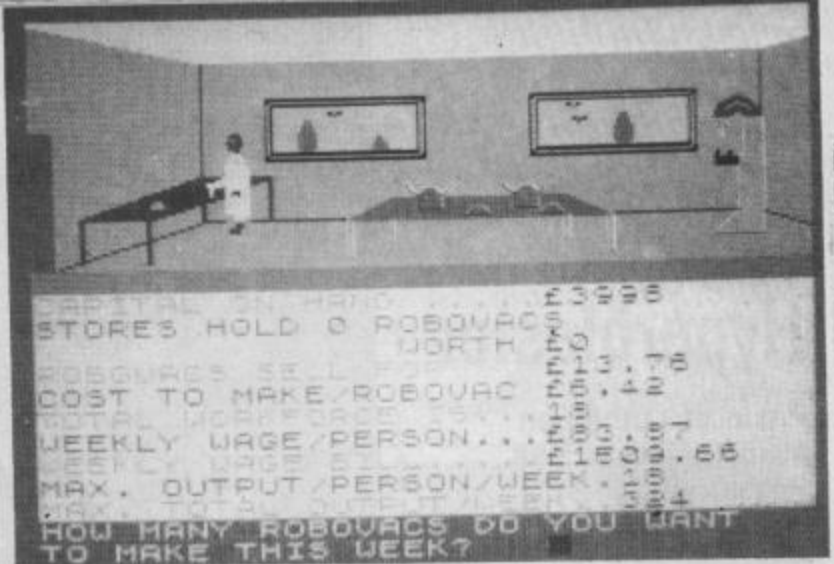
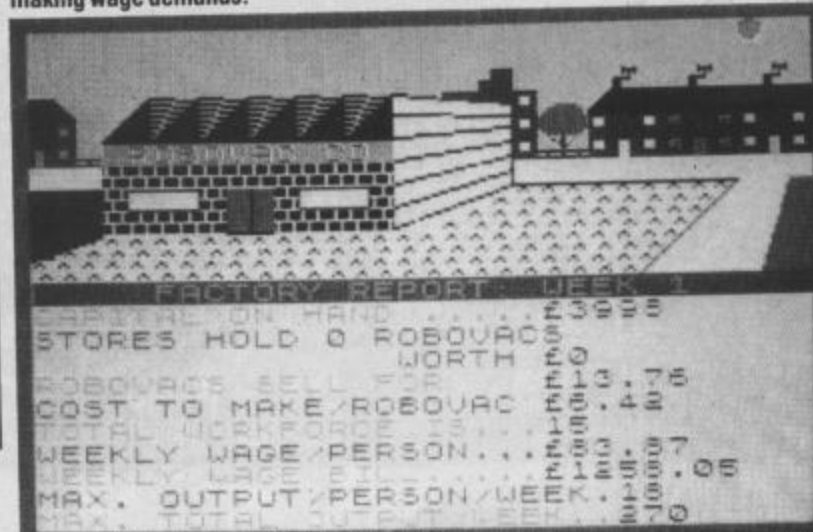

An idyllic setting for making Robovacs - and money if you can...

fixed factory report, to which you return after each round for an update on the status. This starts you off with an amount of capital (not much), Robovacs in store (none), present cost of manufacture per unit, total number of workforce, weekly wage, total weekly wage bill, maximum output per person, and total output possible per week. Your first task is to decide how many more people you can afford or want to employ. Next you must decide how many Robovacs to make in week one. You are then told how many were made, the target figure suffering because of absences through illness or adverse travelling conditions, or perhaps stock delays or machine failures. Having established the actual total made, the computer then sells your stock for you, informs of how many were sold and updates the status report. When this is complete you are shown the wage bill and income tax amount, and finally whether you made a profit or a loss.

The game is accompanied by graphics throughout, about six different pictures from the exterior of the factory unit to the sales office with its optimistic graph in the background, right through to the Crown Court where you are bankrupted!

CRITICISM

● 'Bossman, because of its colourful graphics, is a quite lively industrial simulation. But I suspect the graphics have eaten up

some valuable program space with the result that the simulation is rather simple. There could have been more made of buying stocks of raw materials and relating this to overall production; also perhaps more made of the selling side. This would have lifted the skill factor in playing the game and counteracted the usual irritation of those random elements like high winds flattening your factory or your workforce going on a go-slow for no apparent reason. Nevertheless, *Bossman* provides a few hours of fun.'

● 'This is one game where I can guarantee you won't make a profit! Graphics add a bit of colour to the game and there is good use of sound to enliven the proceedings. The main problem to playing this game is that it is too difficult to expand as the possible profits keep getting eaten up by adverse happenings. I discovered a way of getting round wage rise demands. Refuse the Union's demand - say 4% - and then offer them 10%. The computer then reports that the Unions are happy to accept your offer of 0%! Now that's what I call harmonious working! The responses are a little slow. Overall, not the best I have seen of this type of game.'

● 'To be really enjoyable to play, this type of strategy/simulation game needs to echo real life as much as possible, but *Bossman* suffers too much from the random disaster element to be compelling or addictive. I gleaned all the enjoyment I thought I was likely to get from it within three-quarters of an hour. The graphics make a nice change to the usual, although the claim to 3D only refers to the way they are drawn, and they are quite static.'

COMMENTS

Control keys: numerics and ENTER all screen-prompted
Graphics: nicely detailed
Colour: well used

Sound: lively beeps and whistles
Skill levels: 1
Originality: typical of its kind
General rating: fair to average, providing only below average opportunities for skill. Probably a good starter for younger children.

| | |
|----------------------------|-----|
| Use of computer | 45% |
| Graphics | 55% |
| Playability | 53% |
| Getting started | 59% |
| Addictive qualities | 30% |
| Value for money | 38% |
| Overall | 44% |

New Venture

Producer: Falcon
Memory required: 48K
Retail price:
Language: machine code
Author: David Holden

New Venture will probably be a useful guide to setting up your own trading business, as it's all about making money out of being a shop keeper – a uniquely British thing, we're told. **Falcon** is a new company and this is their first game. It comes as instructions on one side of the cassette and a loader routine for the game which is on the other side. It's worth looking through the instructions first, which are detailed without being confusing and contain many useful hints on the parameters by which your performance will be measured, as well as some explanation on the random elements in the process of shop keeping both for real and in the game. None of these instructions is so complex that a printer is essential for play, although during the game a printer makes life easier.

You kick off with a fairly generous £25,000 (a legacy perhaps). First task is to select the site and type of shop. Up for grabs are four types: a small frontage local village shop costing £15,000 freehold; a double frontage local village shop costing £22,000 freehold; a medium sized town central shop costing £10,00 per annum rent; and a large store in the shopping precinct costing £20,000 per annum rent. You must sort out which you would like, since they each have their obvious advantages and disadvantages. In order, they each have a rising potential in turnover.

When this is selected you must pick what to trade in – clothes, DIY/Hardware, Sports gear, Groceries, Newsagents or a shoe shop. Again, each has characteristics, some being more dependent on seasonal changes than others. When this is done you are informed of the rent/sale price, solicitors fees and costs or repairs. Together these will probably take you over the £25,000 you have, but the friendly bank manager is there to help.

Now you may elect to commence trading (not much good without stock of course), place advertisements in the local free sheet, local daily, local radio, or

This is followed by the bank statement and also shows the amount outstanding on your loan from the bank. You are now ready to repeat the process for the next month.

From time to time people keep coming up and asking you whether you would like to buy something from them, always luxury goods of some sort. You score points the more of these items you can afford, and they are tax deductible from the business, so it's worth it if you can. The overall objective of the game is to become rich enough to buy the fabulous Falcmobile. There are a number of random elements and variables which

more headaches like ratty staff and insurance problems. This sort of game can take a long while to play if you're good at managing a shop, and if you like strategy games of this nature, then this is a good one for you.'

● 'The program allows for print-outs at most stages, which is useful because many times you have to make decisions about the categories of stocks you have, like whether to have a sale, and as they are only labelled with letters it is easy to forget quite what it is you're deciding on. The printouts also form a permanent record of your progress and allow you to see patterns emerging as one year flows into another. I thought *New Venture* was a realistic simulation, at least as realistic as possible on a small computer, and certainly better than many other similar games I have seen recently.'

COMMENTS

Control keys: mostly single input
Responses: reasonable to very quick
Colour: sensibly used
Graphics: text only with clear bar codes
Sound: very little, but useful entry beeps, nice tune
Skill levels: variable depending on shop and stock
Originality: first of its kind given that the financial strategy game isn't new, but the nature of this scenario is
General rating: very good

| | |
|----------------------------|-----|
| Use of computer | 73% |
| Graphics | N/A |
| Playability | 79% |
| Getting started | 83% |
| Addictive qualities | 78% |
| Value for money | 78% |
| Overall | 78% |



HOW THE RATINGS WORK

| | |
|-----------|--|
| Under 30% | a waste of time |
| 31-40% | generally poor, but may appeal to some |
| 41-50% | average |
| 51-55% | reasonable if type of game enjoyed |
| 56-60% | good on most counts |
| 61-70% | generally recommended |
| 71-80% | highly recommended |
| 81-90% | knight of the British Empire |
| Above 90% | words fail |



They say we're a Nation of Shopkeepers – but how good are you?

have posters delivered locally, visit your bank manager (as mentioned!), check your bank statement (not good at the start!), check your update stock, take out insurance or quit. At the bank you can apply for a loan, extend one, repay it or shoot yourself. Checking stock will reveal zero, so it's time to buy – a graph shows how much you are purchasing and in what category. There are six to select from labelled A to F, some seasonal, some good all round sellers (you start off in January), and a 'new line'.

Having stocked up, and advertised if you can afford it, you start trading. Again the graph reappears and shows sales in each category. This is followed by the monthly figures status, showing how much money was made selling each category, the percentage of bought-in stock sold and the total takings. A total stock sold figure is given and the total takings. A keypress then reveals your balance sheet for the month and will include the variable costs like wages, house-keeping, gas, electricity etc., with a total profit/loss figure.

include wage demands, the taxman, Vatman, accountancy problems, insurance and associated risks to stock and property, and inflation.

CRITICISM

● '*New Venture* is fairly sophisticated as these strategy finance games go and allows for an absorbing game. The program is very user-friendly, prompting at each stage and mostly accepting input at a key press. It isn't in any sense 'flashy' but it does seem to be pretty comprehensive and demands a lot of common sense from the player. It is also mercifully free of the more usual random element disasters that ultimately lower the addictive qualities of such games. I thoroughly enjoyed playing it.'

● '*Having a variety of shop types as well as commodities in which to trade is a good idea, since it gives more playability to the game. If you do well in a small village shop, you can then try your hand at a larger town one, where there are many*

ATIC ATAC

ACG KEY WINNER FOUND!

The CRASH offices reeled under the weight of postal tubes and envelopes as entries for our Atic Atac map competition poured in! It soon became clear that it wasn't going to be an easy decision to make.

We asked you to give as much detail as you could sensibly fit in and how you did it was up to you. Clearly, this was a competition which required playing skill, but more importantly organisational and artistic abilities as well. The standard of so many entries was remarkably high.



The judging room, brimful with entries.

The judging took place in a large office room at the new CRASH HQ in Ludlow, where the maps were laid out on the floor for inspection, covering all the available area. After an hour's hard work a short list of 30 entries was made. Five judges were involved, Editor **Roger Kean**, Art Editor **Oliver Frey**, Designer **David Western** and two of our reviewers **Matthew Uffindell** and **Chris Passey**.

Eventually the field was narrowed to three and the choice seemed almost impossible, each had their own merits. So a ballot was taken, with each judge secretly awarding points – three to

their favourite, then two and finally one point. And so the decision was made and the winner of **THE ULTIMATE PRIZE** chosen!

* * * * *

ACG KEY WINNER

The winner of the golden key of ACG is **Malcolm Berry of Rayleigh, Essex**.

Malcolm presented his map in book style – favoured by many entrants – with a colourful rendition of the Atic Atac cover. It included a detailed key to the map, objects, monsters and secret passages.

* * * * *

RUNNERS UP

The two runners up with whom the final battle was fought were entries from **Stuart Spalding** of Roxburgh, Scotland and a trio of cartographers from Corby, Northants being: **Alan Mears** (artist), **Stuart Mears** (explorer) and **Stephen Black** (ideas). The Corby trio also presented their entry in bound book form, and very elaborately too. The judges felt that their maps were overall the most colourful, but Malcolm Berry's rendition was slightly easier to follow. Stuart's entry was on several sheets and was felt to be among the best drawn and looking maps of all with a detailed key and some very neatly designed special text, but suffered slightly in comparison with the others in lacking a finished form. Truth to tell, there wasn't a lot between them, and it's a shame there aren't three keys to give away, but that would spoil the uniqueness of this very special prize! But as a special consolation the runner-up entries will be presented with a copy of Ultimate's next game *Underworld*, as soon as it's available.

As the standard was so high overall, there were several entries which certainly deserve an honourable mention.

Senior Aircraftman Neil Robert Foster, serving with

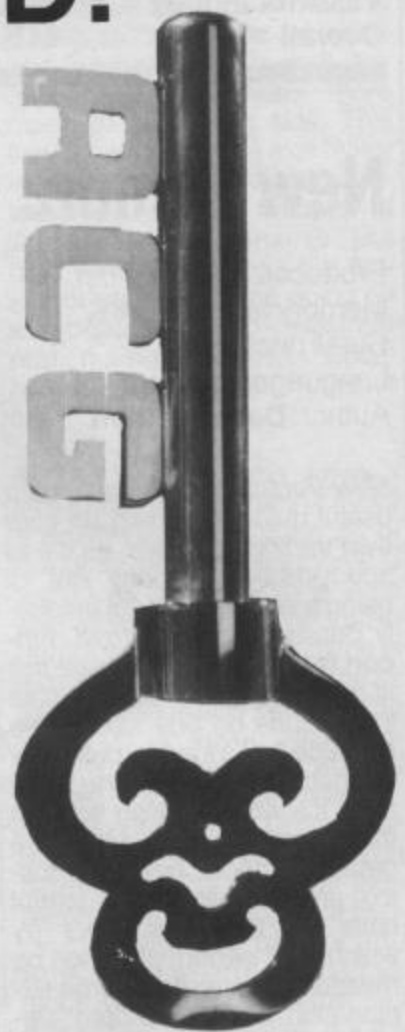

the RAF in Germany sent in a single sheet containing all the levels and a key, very neatly executed and clear. **G. E. Brown** entered a set of architectural plans with every conceivable detail presented just as they would be if the castle were really to be built. And **P. D. Coules** sent in the most professionally finished work of the lot.

So congratulations to Malcolm Berry, who will be receiving his golden key of ACG very soon. And thanks to everyone who took so much trouble to take part.

fantasy

SOFTWARE

We're sorry you've had to wait so long for our first new release of 1984 but your patience will be well rewarded.

From Bob Hamilton, author of 'The Pyramid' and 'Doomsday Castle' we present BEAKY AND THE EGGSNATCHERS and introduce Beaky, our new star of the video-game screen.

(Ziggy is having a well earned rest!)

Beaky belongs to the family of Andromedan Armed Condors, the rare goggled variety.

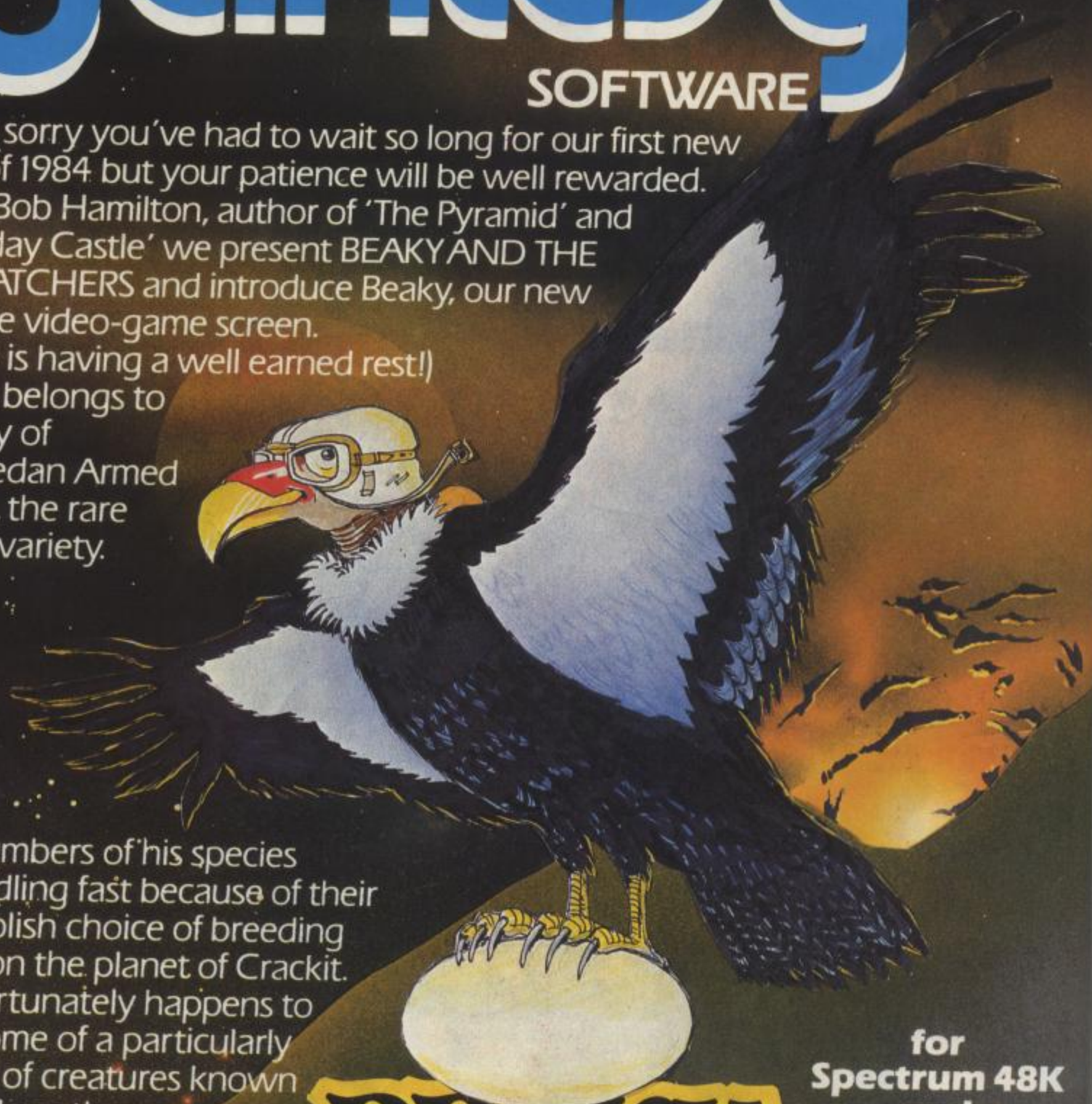

The numbers of his species are dwindling fast because of their rather foolish choice of breeding ground, on the planet of Crackit. This unfortunately happens to be the home of a particularly evil band of creatures known collectively as the Eggsnatchers. Their sole malicious intent in life is to extirpate Beaky's species by stealing or destroying the eggs by any foul means available.

for
Spectrum 48K
and
Commodore 64

BEAKY and the Egg Snatchers

Your objective is to try and brood, hatch out and rear as many little Beakys as possible through 12 different screens of formidable but delightful arcade action.

FANTASY SOFTWARE is available from W.H.SMITHS, JOHN MENZIES, BOOTS, WOOLWORTHS, LASKYS, GREENS, RUMBELLOWS, SPECTRUM GROUP and all other good software retailers. Beaky and the Eggsnatchers is available for 48K Spectrum and Commodore 64 at £6.50 on cassette or on disk for the Commodore 64 at £9.50 from

FANTASY SOFTWARE, FAUCONBERG LODGE, 27A ST GEORGES ROAD, CHELTENHAM, GLOS GL50 3DT
despatched by return first class post together with free membership of the Fantasy Micro Club.

Trade Enquiries welcome - telephone 0242-583661.

COMCON

Programmable
Joystick Interface for
the Spectrum

£19.95

incl. VAT and P & P



QUICKSHOT 2+2 JOYSTICK

modified to incorporate
2 independent fire actions
and no rapid fire option

£13.95

incl. VAT and P & P



FLIGHTLINK JOYSTICK

with 2 independent
fire actions

£10.50

incl. VAT and P & P

CURRAH μSPEECH UNIT

fits into COMCON extension slot

£29.95

incl. VAT and P & P

Simple and fast programming:
Plug the six function connectors
into the required Spectrum key
positions — Ready!

Two independent fire actions:
Photon Blasters and Neutron Bombs
at the touch of your fingertips.

Extension port for Currah Micro-
speech unit: Combine joystick with
sound and speech for ultimate
arcade action.

Compatible with all Atari type
joysticks including Quickshot II
(without rapid fire action).

Interface operates joystick parallel
to keyboard: Joystick action com-
patible with any add-ons including
Microdrives.

The affordable alternative: Lowest
price yet for programmability.

| Qty | Code | Item | Item Price | Total £ |
|-----|------|------------------------|------------|---------|
| | 01 | Comcon Interface | @ £19.95 | |
| | 02 | Flightlink Joystick | @ £10.50 | |
| | 03 | Quickshot 2+2 Joystick | @ £13.95 | |
| | 04 | Comcon + Quickshot 2+2 | @ £31.90 | |
| | 05 | Comcon + Flightlink | @ £28.45 | |
| | 06 | Currah μSpeech unit | @ £29.95 | |

I enclose a cheque/postal order made payable to FREL LTD for: £

Dealer Enquiries Welcome
Phone Ludlow (0584) 4894

Mr/Mrs/Miss _____

Address: _____

Postcode: _____

Send to:

FREL LTD.

Hockeys Mill, Temeside,
Ludlow, Shropshire SY8 1PD

*Crash
Competition*

A CRASH Exclusive!

As a very special and exclusive offer to CRASH Readers, *Micromega* are running a competition with us for their new 3D game *Full Throttle*. 20 lucky people have the chance of winning a copy of *Full Throttle* and a fabulous poster of the game. *Full Throttle* has only been available for two weeks now, so this is your chance to get in on the act and race your way around ten international circuits against 39 other top class riders!



Full

THROTTLE

18

All you have to do is correctly answer the simple questions below (everything can be found in past issues of CRASH, so there's no excuse!).

The first 20 correct answers drawn from the bag will each receive a copy of *Full Throttle* and a poster. The ten runners-up will each receive a poster. All entries (on a postcard please or the outside of a sealed envelope) must be received by last post August 30.

Full Throttle Competition

1. Name all the planets depicted in the game *Code Name Mat*
2. How many types of alien are in *Code Name Mat*?
3. Apart from bikes, what other targets are there in *3D Deathchase*?
4. What is the technical term used to describe the kind of 3D used in *3D Deathchase*?

Answers to: Full Throttle Competition,
CRASH Magazine, PO Box 10,
Ludlow, Shropshire SY8 1DB

ZX MICROFAIR

EVERYTHING FOR SINCLAIR COMPUTERS

THE GREATEST SHOW ON EARTH

ONCE AGAIN AT ALLY PALLY
SEPTEMBER 8th 1984

FEATURING A GALAXY OF EXHIBITORS
WITH SPECIAL OFFERS AT THE SHOW!

SEE THE MIGHTY KINGDOM OF SOFTWARE!
THRILL TO THE COMPUTER HARDWARE!
GASP AT THE RANGE OF ADD-ONS, BOOKS, PERIPHERALS!
WITNESS THE OUTSTANDING FEATS OF THE QL, SPECTRUM AND ZX81!
One Day Only! Don't Miss It!
Only £1.25 (Adults) 60p (Kids)



SEND NOW FOR REDUCED-PRICE ADVANCE TICKETS

Post today and you can have Advance tickets at £1 (Adults) and 50p (Kids). Please include a stamped addressed envelope with your reply and make cheques/PO's payable to ZX Microfair.

Name:

Address:

Please send me advance tickets @ £1.00

Please send me advance tickets @ £0.50p

Post to Mike Johnston, ZX Microfair, 71 Park Lane Tottenham, London N17 0HG.

EXHIBITORS! Phone Mike Johnston on 01-801 9172 for details and availability of stands at the show!

12th
ZX MICROFAIR
at Ally Pally on
8th September 1984

Find The Titanic!

Crossing the North Atlantic in the years between the coming of steam and the end of the big ocean liner era, was a matter of enormous prestige for the shipping companies. The fastest crossings meant the shipping company being awarded the most coveted of trophies – The Blue Riband.

Between 1900 and the Second World War this competition became most intense with bigger and faster liners trying to outdo each other. For the Blue Riband holder the prestige meant more passengers, more cargo – more money!

The most famous liner of all time was one, ironically, never to win any prizes – White Star's Titanic. The biggest ship ever to be built at that time, she was the most luxurious, the fastest and the safest, incorporating the very latest design in watertight compartments and bulkheads. White Star Line were so proud of the Titanic that as she sailed on her highly publicised maiden voyage to America, the press call her 'Unsinkable'.

The weather was fine, but out in the North Atlantic freak weather conditions had permitted large icebergs to float further south than expected – and radar hadn't yet been invented...

In the June issue of CRASH we reviewed the strategy adventure game by R & R Software called *Titanic*. Now, in association with R & R Software, we are offering readers the opportunity to win a copy of *Titanic*. There are 100 copies to be won by answering the questions. If you're at a loss, take a close look at the review in issue 5 (June).

Entries on a postcard (or a sealed envelope) please to **TITANIC COMPETITION, CRASH MAGAZINE, PO BOX 10, LUDLOW, SHROPSHIRE SY8 1DB**. The closing date is **August 30**. The first 100 correct entries drawn from the bag will each receive a copy of R & R Software's game *TITANIC*. Best of Luck! Don't forget your name and address!

TITANIC COMPETITION

1. In which month and which year did the Titanic sink?
2. What caused the ship to sink?
3. What two things were extraordinary about the famous sinking of the biggest, fastest and safest ship ever built at that time?
4. Into how many distinct stages is the game split?
5. Having discovered the last resting place of the Titanic, what are you then seeking?
6. Thanks to N.A.S.A., you are given a satellite photo with how many possible locations shown on it?
7. Name two other games by R & R Software.



**YOU'VE
READ ABOUT
THE SOFTWARE -**

NOW PLAY IT!

CRASH is the only magazine to offer you a direct link between reading about software and playing it! Forget hours of fruitless hunting in shops for that extra special game you read about and want - and want now. **CRASH Mail Order** will move stars and planets (even the 8.15pm from Paddington) to get you any of the brill (and even not-so-brill) software from the big (and even not-so-big) software houses reviewed in these pages. Because **CRASH** believes that you **reading** about software is only second best to you **playing** the real thing - and forming your own opinion. Bazoola software and meep software - don't just believe us - **see!** Order any games, adventures, utilities, simulations and educational software mentioned (and not-so-mentioned) in **CRASH** with the order form later in this issue.

CRASH - SPECTRUM SOFTWARE



RE HEAVEN AT YOUR FINGERTIPS

CRASH

THE EASIEST WAY OF BUYING SPECTRUM SOFTWARE YOU WILL FIND!

All you have to do is fill in the form below and send it off. We still offer a *FREEPOST* ordering service, but please remember that it can take three to four times longer to reach us than ordinary First Class post. If you would prefer a speedier delivery then we recommend you use a stamp. Orders received with a first class stamp will be despatched within 24 hours by first class post.

ANY OF THE SOFTWARE
REVIEWED IN THIS ISSUE* OF
CRASH MAGAZINE MAY BE
ORDERED BY MAIL USING THE
FORM BELOW.

*In the case of very new programmes which may not be available from the software producer yet, it is advisable to ring first and check on availability.

CRASH MICRO GAMES ACTION ORDER FORM

Telephone Ludlow (0584) 5620.

Please send me the following titles: Block capitals please!

| Title | Producer | Amount |
|-------|----------|--------|
| | | |
| | | |
| | | |
| | | |
| | | |
| | | |
| | | |
| | | |
| | | |
| | | |

Name.....
Subscriber No. if applicable

Address.....
.....
.....

Postcode.....

All prices are as quoted under review headings and include VAT. Crash Micro Games Action make no charge for postage and packaging. Customers in Europe should add 50p per item for post and packing. Outside Europe, please write first so that we may advise on postage rates.

Please make cheques or postal orders payable to 'CRASH MICRO'. From Europe we can accept Sterling cheques or Girocheques.

Sub Total: £
Less Discount £
Total Enclosed £

SPECIAL DISCOUNTS

£1

OFF ANY ORDER WORTH MORE THAN £20

50p

OFF ANY ORDER WORTH MORE THAN £10

Sorry - only ONE voucher per order!

CRASH MICRO, FREEPOST (no stamp required), LUDLOW, SHROPSHIRE SY8 1BR

YOUR PLANET NEEDS YOU!

Train to save Civilisation by

Subscribing to

CRASH

MICRO GAMES ACTION

Subscribers' Discount ~

50p off each Crash Micro

Mail Order item!

● Get your copy

LAST CHANCE

ahead of the crowd

AT THIS PRICE

● UK: 6 issues £4.80 (post free) 12 issues £9.00 (post free)

● Europe £15 (12 issues post incl.)

I would like to subscribe to CRASH for 6/12 issues
Starting with issue _____

Name

Address

Postcode

I enclose £ _____

CRASH (Subs), PO BOX 10, LUDLOW, SHROPSHIRE SY8 1DB





do you're left nowhere until you re-read the message and there's no running back to the ship once you're out. These aren't particularly bad points, it just gives the start of the game a very predictable feel with a textbook linear development. (No, I haven't written the textbook - in any case it's best to book your

lately straight-forward, and I do like to play as much of an adventure as possible, it was fortuitous indeed to hear the solution from the horse's mouth.

The vocabulary consists of mainly Verb/Noun input but in some cases longer sentences may be necessary. The language can be a little pernickety

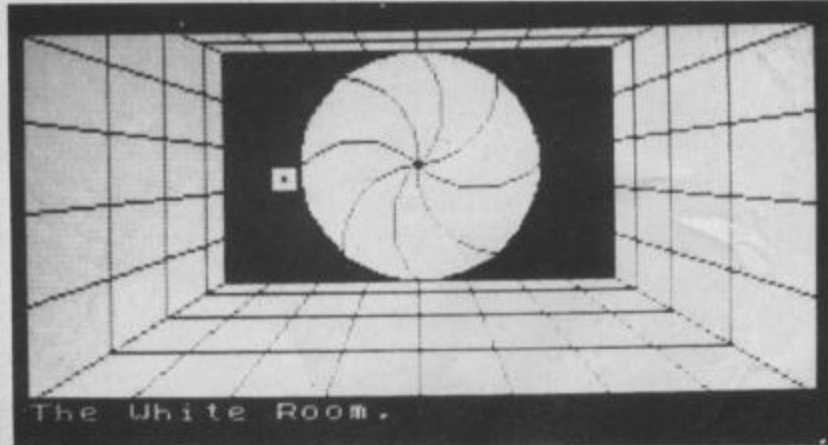

spot on Russell Harty and Breakfasttime and then write the book.)

You'll find when you play this game that access is easy and quite safe throughout the first 23 locations, apart for the aggressive android guard in the Guard Room. This first stage completed, you reach an impasse as the problems remained difficult even after consulting the program listing.

It's a shame there are no easy problems to ease you into the adventure. Without them an adventure takes on a very eerie feeling and you keep wondering what you've missed.

The impasse is most evident when you chance upon a plate set in a panel. It is almost certain that you get through this way by opening the panel but getting the exact words takes a long time. In fact I had given up until I bumped into **Richard Paul Jones** of Interceptor at the Earls Court Computer Fair whereupon I received some timely advice. Considering I found the rest of the game re-

when, for example, you must 'SHOOT ALIEN SOLDIER' as simply entering 'SHOOT SOLDIER' will not do. One of the realistic things about this game is the way dead soldiers still lie where they were slain when you return to a location. Other assailants you might meet include giant slugs, a fierce scaled creature on the bridge and some impregnable ivy.

Message from Andromeda has some very good graphics but there aren't that many. Strangely enough - and commendably - some of the best are towards the end for only the most dedicated of reviewers. The game is good value at £5.50.

| | |
|----------------------|----|
| Difficulty | 8 |
| Atmosphere | 5 |
| Vocabulary | 7 |
| Logic | 7 |
| Debugging | 10 |
| Overall Value | 7 |

The game has a layout now familiar to the Digital Fantasia Mysterious Adventures. A picture can be switched out from the top half of the screen to reveal the objects and exits while the lower half of the screen accepts input and puts up an occasional comment. A click accompanies all entries including the space key.

You find yourself in the freighter's social room where you can see a sign and a closed steel door - and a couch. I wonder if this couch has a key in it as in *Waxworks*? On examining I do indeed find the key and a less than useful crumpled note. Well this is believable enough since there's probably about ten pounds worth of change down the side of my couch and no doubt keys and crumpled notes. As is the norm with Mysterious Adventures you're told in the bottom half of the screen that 'I'VE FOUND SOMETHING!' and you must look within the list of objects at the top to find out exactly what it is you have found. A related report 'SOMETHING HAPPENED!' greets you when you turn the dull illuminant rod. Unfortunately you are not told exactly what has happened although to be fair you are told when you look at the inventory - you carry a glowing rod.

Moving south you enter a crewman's cabin and through another door (GO DOOR) into a similar crewman's cabin, but if you try to return to the first cabin you are greeted with the report 'WHERE?'. It appears to be a one-way door - strange if not incredible. I don't know about you but I'm no fan of the one-way door. Further on, when travelling from the Captain's Cabin to the Workshop you find your way back blocked, a ploy to force you down into the maze. At times like this you become more aware of the program in the computer and the adventure is that much less convincing. At other times it is the logic of the game which stretches your ability to believe. Would you normally find a circuit board beneath a pillow in a bunk? You are allowed to move the pillow but not to take it - clearly the program is telling you the pillow isn't necessary when it might have been better to find this out for yourself. The more things you can do, whether useful or otherwise, makes a better adventure.

This game has two features which, unfortunately, have become standards. Unfortunately, because adventuring should be an actively developing area and

not a stale, stuffy one. I refer to the maze and the small rucksack phenomena. I gave hints on how to tackle a maze last month so perhaps that will reduce the niggles here. The small rucksack can only carry five or in this case six objects and perhaps it's time for a new angle on this one. Continually dropping and picking up objects can get laborious while often adding little to the game. For example, is the assumption that it's just as easy to pick a long heavy floorboard as to carry a small key justifiable?

On loading this program you are asked 'Resume play on game?' and there is an ugly little bug associated with this. I was at the Vent and pressed **N** to go north but the computer did not respond; instead I was killed by the dust here and since the program then asks 'Play again Y/N?' the previously entered **N** NEWed the computer leaving me to reload a rather long program. It would seem sensible to have a double check where programs might be lost in this fashion.

In case this all sounds a bit too damning I must say that the vocabulary has a powerful EXAMINE which isn't always the same as SEARCH. I would like to see all adventures make use of these words and reserve EXAMINE for examining an object which should return a detailed description, and SEARCH for searching an object to reveal anything concealed about or in it. EXAMINE in this sense may tell you how an object might be used or how it may prove useful later on.

Escape from Pulsar 7 has a very fast response time, has good well-designed graphics that can be easily switched on and off and features 42 as opposed to the Spectrum's more usual 32 characters per line. However, the game lacks that spark of originality and leaves you with the feeling you've seen it all before.



| | |
|----------------------|----|
| Difficulty | 7 |
| Atmosphere | 6 |
| Vocabulary | 7 |
| Logic | 5 |
| Debugging | 10 |
| Overall Value | 6 |

Escape from Pulsar 7

Producer: **Digital Fantasy**
Memory required: **48K**
Retail price: **£9.95**
Author: **B. Howarth & W. Barnes**

The space freighter Pulsar 7 is returning from an exploratory flight to the outer regions of the

Xanotar system, delivering the precious ore Redennium to the minor planetoids that have evolved beyond primitive nuclear power. As part payment you take on board a strange creature for the intergalactic zoo that grows too quickly for its cage, breaks out and is now concealed somewhere on the ship. The creature eats the entire crew but you have been shrewd enough to avoid a similar fate until now when you must abandon the freighter and make your escape in the frail shuttle craft.

Allo? Ah ahm Unspecter Cleudeau of the Sureté....

**NOW
AVAILABLE**

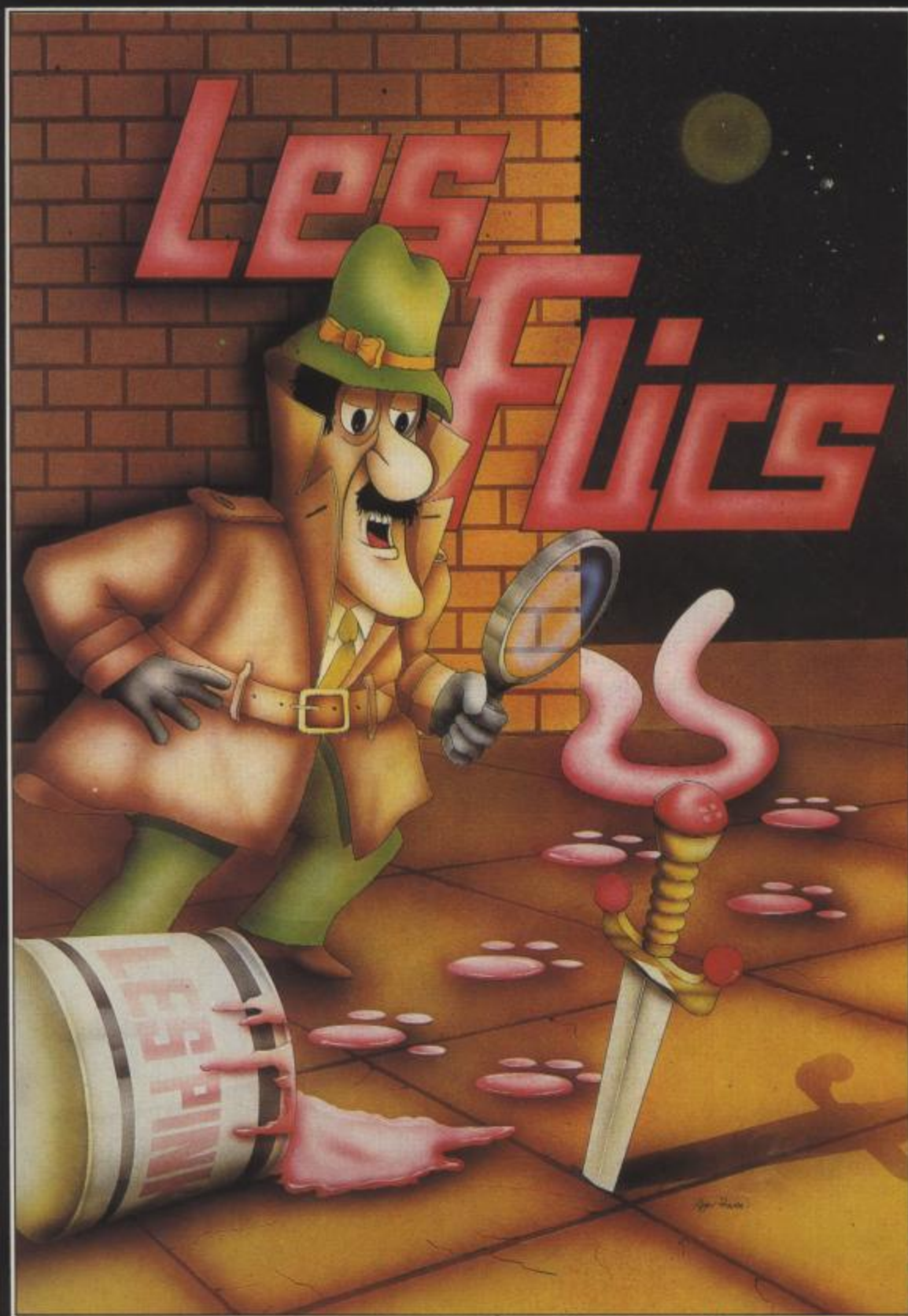

ah neu eggsactley weut yew are eup tew, because that ees mei jeub.

Ah neu yew are geuing tew trah en steal a gem steun in mei care beut eet weel naught be eezee mei frend, eau neu, me and mei trusty servant Kaolin weel be tryin to steup yew.

Not eanly zat, beut Les Flics, the treu gend'armerie eunder mei commant weel be out en force, so, you foel, you 'ave neo chance aggenst Cleudeau.....

You control that Pink character with the tail in your quest for the Purple Puma, a priceless gemstone, avoid the Police cars and enter the buildings, evading Gendarme Kaolin (disguised as a chef) and of course Cleudeau himself.

Pick up the items as you find them, we leave you to find out what they do!

Bon Chance

£6.95

Arcade Adventure For Spectrum 48K

Items to collect:

Dagger Bag

Spanner

Knife & Fork

Key

Money

Disguise

Mask

Diamond



ARCADE ADVENTURE FOR SPECTRUM 48K

The Lords of Midnight

Producer: **Beyond**
 Memory required: **48K**
 Retail price: **£9.95**
 Author: **M. Singleton**

Beyond have produced a game of immense complexity that transcends the simple word-matching of the mainstream adventure and in many respects more resembles a strategy war game. Many features of the game are new or are developed to an elaborate degree setting new high standards in Spectrum software.

The cassette is accompanied by a lavish booklet giving thorough and very sound playing instructions. When I say you will need them, and you most certainly will need to read some of the hints given, I mean this as a compliment to the inventive depth which pervades the whole project.

There is an original reward for the first adventurer to finish off Doomdark, your evil adversary. The prize has the winner cast in the role of fantasy fiction writer as he will become the co-author of a novel based upon the scenes of his unique version of the War of the Solstice. Thus you will have had a hand in creating the first ever computer-generated novel. Had I heard of this idea from a third party I would've immediately dismissed it as half baked folly but having seen the game I should like to be first in line to receive a copy.

A look at the overlay card for the keyboard might show some ways this game differs from the others. Instead of the adventure-style input, here you have a set of keywords. LOOK gives a vista with details of where a character stands. The heraldic shield at the top right tells you through whose eyes you are looking. You can turn a character to look in another direction by pressing the

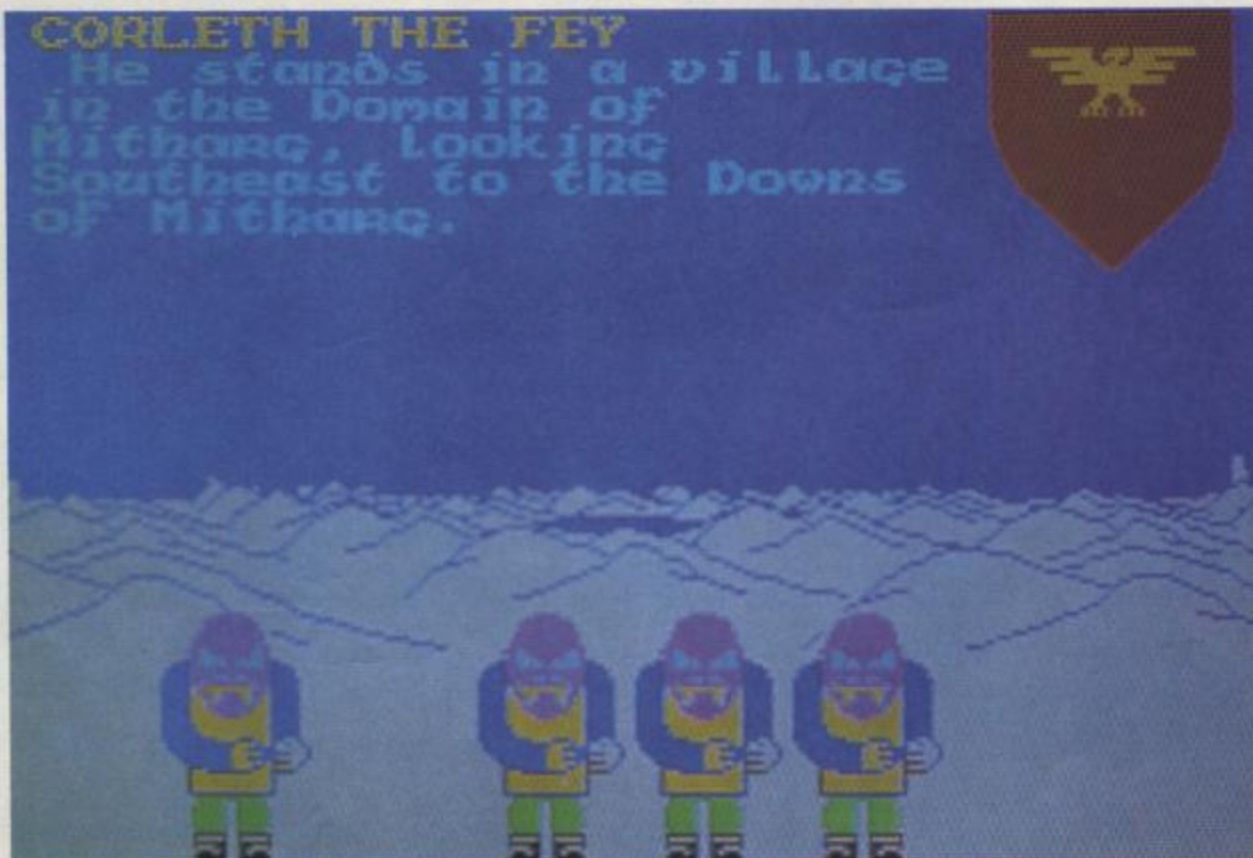

appropriate direction key. THINK gives more details regarding the character and any army he controls is numbered and described. CHOOSE can lead to searching, hiding, attacking an enemy and repairing defences but the options will shrink or expand with different characters and circumstances; a cowardly character will seldom volunteer for daring deeds. SELECT gives you a list and allows access to the characters under your control. At the beginning of the game you only control four characters but can employ many more once you have visited the various citadels and keeps scattered about the land.

Although this game is so complex it is difficult to review in the few days available there is one feature which impresses on the very first frame of the game. The graphics which show your journey through the land of Midnight are little short of stunning. The panoramic views are drawn in full perspective and consecutive moves see mountains, forests, hills, citadels, towers and fortresses rising in stature as you approach or fade to distant outlines as you leave. The screen as a whole is very well presented as if designed by a graphic artist. There is no crude split on the main screen but instead a pleasing mixture of superb views of the scene, tastefully redefined characters for the text, a heraldic shield depicting the crest under which your character fights, and highly decorative and detailed representations of the numbers and type of foe you might come across. These last are the best I've seen on the Spectrum.

Possibly the most pleasing aspect of the *Lords of Midnight* is its wonderfully coherent storyline.

Doomdark has woken from his slumber and the lands of Midnight are plunged into Win-

ter. This Solstice is the peak of the Witch king's power and it is now that you must defeat him. The computer plays the role of Doomdark and intelligently pits the evil forces against you. A cold blast of fear emanates from the Citadel of Ushgarak, blowing across the Plains of Despair ever southwards to where you are busy marshalling troops. Victory for Doomdark is eliminating Luxor the Moonprince and Morkin, his son. Alternatively he can creep south into the peaceful land of the Free, striking at its figurehead of serenity and happiness - the Citadel of Xajorkith.

If thinking of yourself pitted against the computer fills you with despair don't worry, you have your friends and your own wits. You take the role of Luxor the Moonprince, Lord of the Free and your first task is to travel abroad and gain the support of the other citadels and keeps throughout the land of Midnight and amass an army. As Luxor you have the Power of Vision and the Power of Command which enable you to control other characters loyal to you, move through the land of Midnight and look through their eyes. The closer a character or army is to Luxor and his Moon Ring the less demoralising is the effect of the Ice Fear that emanates from the Plains of Darkness as the ring radiates the strength and warmth of his mind.

Your most trusted companion, and the most important person in the quest, is your own son Morkin who is half human and half fey. By virtue of his unique ancestry Morkin can withstand the utter coldness of the Ice Fear which is increasingly directed at him as he approaches the Citadel of Ushgarak and so lifts some of the burden upon the armies of the Free.

You initially have control over four characters: Luxor, Morkin, Corleth the Fey and Rothron the Wise but as you progress such characters as the Lord of Shimeril and the Lord of Brith and their armies add support to the forces of the Free.

If I run through a typical game it may show you some of the great features it has and perhaps some tips if you've already got a copy.

My tactics, and remember you'll need them as this is very much a strategy game, involved building up armies at the Citadel of Shimeril guarding the western route into the tranquil south-east and at the Keep of Athoril which overlooks a major route south.

Luxor headed south-east past the cave of shadows, through the Mountains of Ishmalay to the Keep of Brith where the Lord Brith is recruited to the cause. Lord Brith travels north-east to the Citadel of Shimeril while Luxor leaves to the east to recruit Lord Mitharg who in turn heads north to Shimeril. Mitharg picks up an extra 100 warriors on his way at a keep in the Domain of Blood.

Morkin travels east to the Domain of Morakith and finds shelter and refreshment at keeps along the way. In the east he gets quite a shock to see Doomdark's troops lined up with 890 riders. Morkin finds it difficult to recruit Lords of keeps and citadels, presumably because he is so young, but does manage to persuade the Lord of Whispers a little further along his way.

Corleth headed east to Shimeril ahead of Morkin and seeks and finds the sword Wolf-slayer - very handy when you meet wild wolves as well as Skulkin and ice trolls. You can become very blasé about killing these creatures but if you are tired they'll give you a nasty

surprise. Corleth is very invigorated and utterly bold and the Ice Fear is mild. In these early stages all is going well.

Rothron goes north-east but, apart from recruiting the Lord Blood who takes his 1190 riders and 375 warriors south to Shimeril, he plays little further active part in the game and comes to an untimely end at the hands of the Skulkin.

During the night of the third day Doomdark has made his presence felt. The bloody sword of battle brings death in the Domains of Kor and Lorgrim which are unfamiliar to me. I consult the map to find they are in the far north in the vicinity of the Citadel of Ushgarak.

Lord Blood loses 10 in the battle of Blood but picks up 100 warriors in a keep in the Domain of Blood on his way south. He finds Lord Mitharg at a keep unaware he is so near to the Citadel of Shimeril where the Free have decided to meet. Blood takes Mitharg south with him.



CRASH ADVENTURE TRAIL CHART



Most computer magazines publish their own charts these days. With only one or two exceptions, adventure games fare badly in these charts. Mainly because few adventurers are stocked by the chain stores who make up the charts.

We at CRASH would like to produce the first adventure chart. This chart will be based on what you think about the games you have played, not on sales figures. This will give the many excellent games not sold

by the chain stores a chance of charting. This should prove a much better indicator of which really are the best adventure games than does any other chart.

To contribute all you have to do is give the adventures you have played a rating **out of ten** and send these ratings to us at CRASH. We will then calculate the average readers rating for each game and draw up the adventure charts accordingly.

Voting on the **CRASH**

Adventure Trail Chart need not affect any votes you might want to send in to the main **HOT LINE CHART**, so don't go dropping adventures out of your **HOT LINE** votes because you also want to vote for the **ADVENTURE CHART!**

The names of all contributors will go into the bag for a monthly draw and the first out of the bag will win **£40 worth of software** and a **CRASH tee-shirt**, with five runners up winning a **CRASH tee-shirt** each.

You may **WRITE** in to us or ring us on the **CRASH HOTLINE PHONE-IN NUMBER** but please remember to tell the answering machine that your vote is for **THE ADVENTURE CHART**. The number is **0584 3015**.

CRASH ADVENTURE TRAIL CHART, PO BOX 10, LUDLOW, SHROPSHIRE SY8 1DB

The Lords of Shimeril, Brith, Blood and Mitharg are now encamped within the relative safety of the Citadel of Shimeril, overnight losses being small – say 5 to 10 warriors and about the same riders per army a night.

In the later stages of the game Luxor recruits and sends Lord Dawn to the citadel with 1200 warriors and 600 riders bringing the total warriors in the Citadel of Shimeril up to 3500 and riders to 4000. Later Luxor finds Athoril, with its keep and Lord Athoril and begins to build up forces here, the point I had chosen as the second major bastion of defence and counter attack. The Utarg of Utarg marches his 1000 riders to this second meeting point. However, on his way he is not so committed as to recruit other armies and this is left for Luxor to do.

At the end of the seventh day at nightfall, when looking throughout the eight compass directions, I could see the silhouettes of the towers, citadels and armies that surrounded me, my thoughts turned north to Morkin who I now knew had this very day penetrated deep into the dark Mountains of Ugrom, into the Tower of Doom and at this very moment was wondering how he might get back with that precious object held tightly within his grasp. He had the Ice Crown.

| | |
|----------------------|-----|
| Difficulty | 8 |
| Atmosphere | 10 |
| Vocabulary | N/A |
| Debugging | 10 |
| Overall Value | 10 |

Colditz

Producer: Phipps Associates

Memory required: 48K

Retail price: £6.95

Author: T. Barber

Phipps made their name with *The Knights Quest* and have quickly followed it with many similarly presented pieces. This latest has you prisoner of the Germans in Colditz Castle.

The game uses the same split-screen graphics and scrolling text window technique as its famous predecessor and is yet, curiously enough, written by a different author. Unfortunately, it also retains the curious hold



up in loading. The first section gives you the information, some of which is far too trivial to be included in the program and would be better placed on the cassette insert. You then start the tape once more to get the loading screen and the main program itself.

Many early Spectrum games had reams of information displayed on the screen and you'll no doubt remember how difficult it was to read – especially with a white background on a colour TV. I think the general shift from screen instructions toward more sophisticated cassette presentation is a good move. After all, the illegal copying of a tape isn't quite as effective if you have to forfeit the complex playing instructions left behind with the packaging.

The game takes a long time to load but the loading screen is very colourful depicting the sombre outline of a prisoner of war camp. On pressing a key you are asked if you are starting a new game. Perhaps it's just me being pedantic but I really had to think before answering yes. It may have been better to have had something like 'DO YOU WISH TO LOAD A SAVED GAME'. Perhaps again I'm just being awkward but I seem to have done a lot of button pressing and waiting to

have the first frame in front of me.

Your mission is to aid the escape of a prisoner locked away in a solitary cell of the castle. You begin in the courtyard which has different graphics to distinguish between the NW, NE, SE, SW sectors.

The first graphic depicts the NW courtyard and you notice the high standard of the graphics, better than those in *Knights Quest*, but likewise tucked away in the top left corner. Although I have reservations regarding the artistic layout and impact of this arrangement (a darker background with light print may have, quite simply, lessened the gauche appearance) this method of display has one great advantage – it is fast. You can map out your tracks rapidly with the graphics, which are always displayed, acting as useful quick markers. Compare this to moving through a text-only adventure, especially one with a long scrolling list of location descriptions.

The beeps and squeaks the keyboard emits may seem a minor point but an experienced adventurer knows how important it is to enter without mistakes. *Colditz* has a good selection of distinguishable beeps. Each letter entry including the space key – a common source

of error on the Spectrum – has a loud beep. When you are told of your inability to walk through doors or if the program needs you to be more specific a beep will draw your attention to the computers remark in the bottom half of the screen. The beep that tells you the program is ready for your next input is good but rather necessary as although the graphics are fast the program itself is a trifle slow. 'Machine coded to give fast responses to your commands' says the cover but not fast enough for my taste.

On delving deeper into the adventure the game becomes eminently mappable but the early impressive graphics dry up a little. At a guess I'd say that the number of locations with graphics falls well below 50 percent. This is somewhat counteracted by detailed descriptions and one doesn't expect miracles with only 48K but if you are new to the way in which adventures are marketed it may be worth noting in the text vs. graphics debate. Just for the record my purist instincts favour detailed word descriptions but with a colour TV an attractive, fast graphic never goes amiss.

The language used is basically Verb/Noun with two steps to open a door – unlock, then push open. The usual direction abbreviations are, thankfully, provided: N, S, E, W, U, D. The first four letters define the other nouns. Verbs include look, quit, get, drop use, open, inventory and examine. Elsewhere the language can appear a little atypical e.g. LOWER ROPE rather than the more usual TIE ROPE. THROW ROPE and then you can immediately climb up!

By the way, although I try my best to complete a reasonable amount of an adventure in order to give fair comment, I am indebted to Phipps and Trevor Toms for providing what is indeed a 'Supa Solution' sheet. Not only does this put the reviewer into a favourable frame of mind but also allows people like myself to impress with the easy wisdom the sheet imparts.

Colditz has fine graphics with many interesting, logical problems and is well worth the asking price.

| | |
|----------------------|---|
| Difficulty | 7 |
| Atmosphere | 7 |
| Vocabulary | 7 |
| Logic | 7 |
| Debugging | 9 |
| Overall Value | 8 |

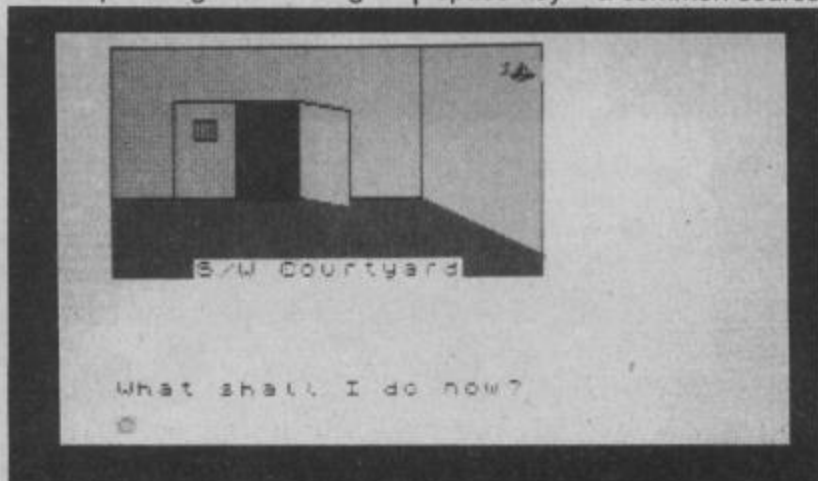

as a
ld of
ugh
eds
keep
the
tom
that
ady
but
ugh
ro-
w.
ast
ds'
ast

This month, after receiving several letters on the subject, I am introducing a coding system for the adventure tips. The clues will have each letter rotated forward one place through the alphabet i.e. A becomes B etc. To get the solution all you have to do is step one step backwards.

I do like to hear what you think of the games you've played and on this subject Ron Wells of Brentwood writes some very interesting comments.

"KNIGHTS QUEST (Phipps): so Crash reviewers thought the plot was thin - only a forerunner of Phipps' much better games. I don't agree. I think this is one of their best. Bet you can't go more than 2 or 3 moves at a time without being stumped. One to keep you frustrated for many, many months.

MAGIC MOUNTAIN (Phipps): a superb adventure containing some intriguing and original puzzles. Dwarves, genies and magic carpets all add to a marvellous atmosphere.

PHARAOH'S TOMB (Phipps): quite a bit easier than other Phipps' adventures, but

still above average with some nice graphics. Very enjoyable and not too frustrating.

MOUNTAINS OF KET (Incentive): a splendid effort, but spoilt for me by the silly combat sessions with which you become thoroughly bored, thus spoiling your enjoyment of the game.

GOLDEN BATON (Digital Fantasia): imaginative descriptions and lovely graphics combine to make this a very compelling adventure. One of my all-time favourites.

THE HOBBIT: undoubtedly a classic - despite the odd bug, and the tiresome repetition when in the dungeons.

PIMANIA: absolute rubbish.

ARTIC ADVENTURES A-E: all highly recommended and of consistently high standard."

Ron goes on to request some help:
"Golden Baton: how do you raise the portcullis?
Pharaoh's Tomb: how do you put out the fire in the fire room?"

XJOEPX'
TBZ UP UIPSSO 'DBSSZ NF'
TBZ UP UIPSSO 'HP XFTU'

After this escape, avoiding an early return is another problem!

Alastair Luxton of Newbury has ground to a halt in Level 9's *Colossal Adventure*. It appears the large snake in the Hall of the Mountain Kings is creating some problems: Well, Alastair, answering two of your questions in one, try

GFSS CJSE

As to where the pirate takes the treasure he steals, I couldn't tell you; he says he takes it to the maze. I've mapped out the first maze and it isn't there while after several visits to the second maze via the stalagmite I still have not found the booty. Is there a third maze or is it a cruel hoax?

Robin Hogg from Swansea is at an impasse in *Velnor's Lair*. He asks: "How do I cross the chasm with molten lava flowing below? I have the 25ft plank but it is too short!"

You will need to create a bridge of course; when you have the necessary object all will become clear.

Mary Henson of Leicester is having problems with sharks in the same game. To pass them

23628: PEEK 23641 +
23642 * 256 - PEEK 23627
- 256 * PEEK 23628:
SAVE "VELNOR 2" CODE
23552,180: RETURN
4. Save game by SAVE "VEL-
NOR" LINE 5

Steven Roberts from Wigan is having trouble moving the elephant in Temple of Vran. Actually Steven, your questions give the solution to the problem! Anyway, here it is:

NPWF JOUS FMFQIBOUT
MPDBUJPO XJUI QFBOVUT.
JU XJMMP JPMMPX
ZPV.ZPV DBO UIFO GFFE
FMFQIBOU.

Mark Richardson of Huddersfield is stuck early on in *Knight's Quest*. After saving the dwarf he cannot get past the dragon or the giant and has been unable to communicate with them. I'm not surprised after trying to kill them! Anyway try:

GFFE ESBHPO

By the way Mark, one letter is enough!

I'll finish off with a problem that both myself and **Stuart Roberts** of Wraysbury have been struggling with. How to do you get through the security door in the Snowball Hilton. Any help would be most appreciated.

This month's twelve pounds of software goes to **Ron Wells** of Brentford for his useful comments. Keep on sending your letters and don't forget each month twelve pounds of software awaits the writer of the most interesting letter.

you will need the key as mentioned by the Goblin Chief. No! You didn't kill him? She also comments that the save routine is terrible. I tend to agree, but it need be no longer. Here, exclusive to Crash, are alterations to vastly improve the save routine.

VELNOR'S NEW SAVE ROUTINE

1. BREAK the initial title screen directly after loading.
2. Delete the following lines:
252 4870
254 6109
4002 6130
4860 6140
3. Insert the following lines:
1 PRINT AT 2,0;"LOAD
SAVED GAME?"
2 IF INKEYS = "Y" THEN
LET V\$ = "LOAD":GOSUB
250:GOTO 100
3 IF INKEYS "N" THEN
GOTO TU
250 IF V\$ = "LOAD" THEN
CLS:PRINT#0;"START
TAPE":"LOAD" VELNOR
1" CODE: LOAD "VELNOR
2" CODE
251 IF V\$ = "SAVE" THEN
SAVE "VELNOR 1" CODE
PEEK 23627 + 256 * PEEK

I'm sorry to say that I can't help him with these, but if you know the solutions perhaps you might drop me a line.

And now for a few problems I can answer.

It's good to see The Hobbit still causing problems. **Paul Jasper** from Malvern, Worcester writes:

"In The Hobbit I never get further than the black river. It says you should look for a boat. I can never find it."

Well Paul, try
UISPX SPQF BDSPTT
SSWFS

and then
QVMM SPOF DBSFGVMMZ
Keith Simpson of South London is still stuck in the Goblin dungeon. To escape from the dungeon:
TBZ UP UIPSSO 'PQFO



REALTIME SOFTWARE



83%
CRASH
Rating!

3-D TANK DUEL

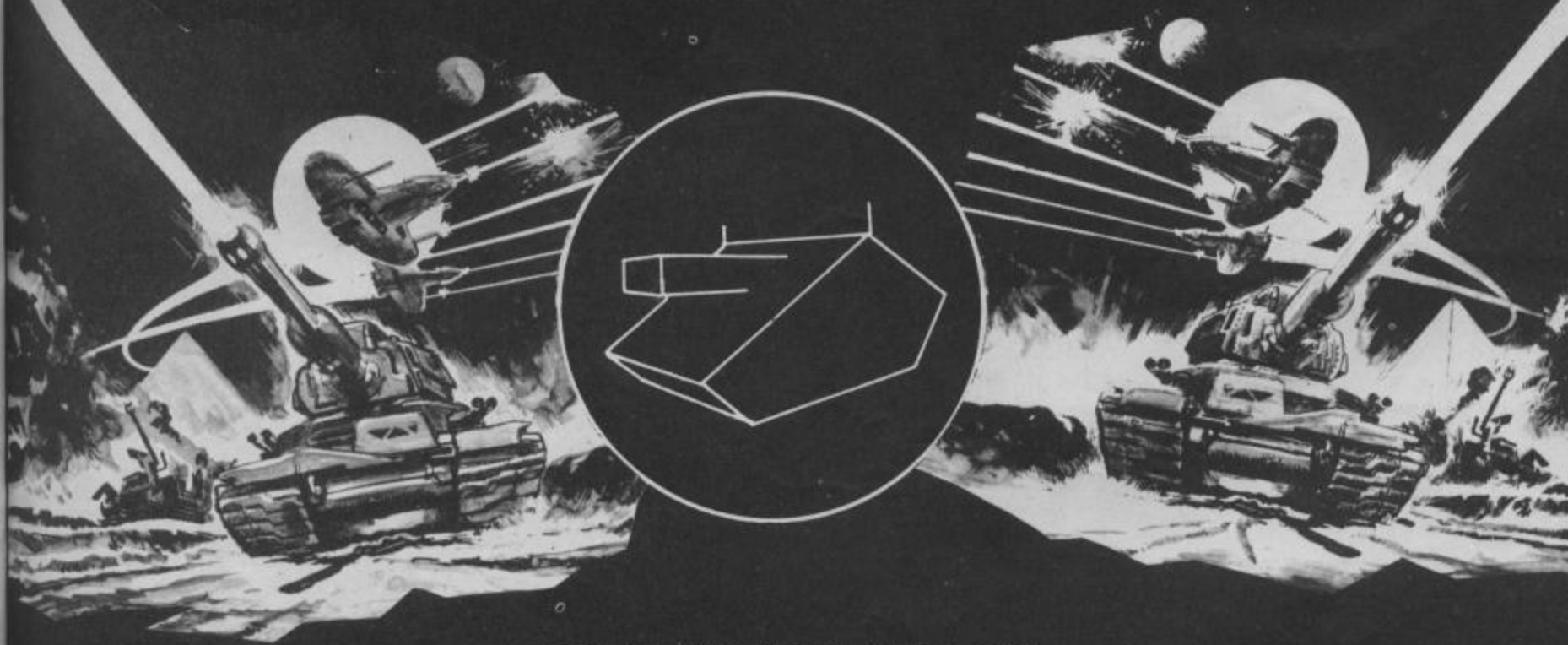

FOR THE ZX SPECTRUM 48K
SINCLAIR, KEMPSTON
AND CURSOR JOYSTICK
COMPATIBLE

Please send me _____ copy/copies
of 3D TANK DUEL at £5.50 each (post and packing free)
Cheques/p.o. payable to REALTIME SOFTWARE

Name _____
Address _____
Postcode _____

REALTIME SOFTWARE, PROSPECT HOUSE, 32 SOVEREIGN STREET, LEEDS LS1 4BJ

The CRASH HOTLINE

AUGUST HOTLINE STATISTICS

Preparations for school examinations don't seem to have affected the numbers of voters this month, with only a slight decrease since July's chart in votes cast over 23,000. *Jet Set Willy* still rides well at the top, having slightly increased its total of the vote to **20.04%**, thus proving that bug or no, it's the most popular game around. *Atic*

Atac and *Manic Miner* each lost a little ground overall, probably to *Sabre Wulf* which received **5.26%** of the total votes cast. The battle between *Code Name Mat* and *Wheelie* was close with *Wheelie* receiving **4.89%** and *CNM* received **4.73%**. Between them, the top ten games totalled **61.17%** of the votes cast.

THE CRASH HOTLINE PHONE NUMBER IS
0584 (Ludlow) 3015

HOW TO USE THE CRASH HOTLINE

Method 1

Ring the Hotline telephone number (above) and record your votes on the answering machine. Please speak clearly, spelling out name and address if it's a 'difficult' one! List your five games starting with the number one.

Method 2

Use the coupon below, making sure you fill in all the details. Pop the coupon in an envelope and send it to us. Alternatively you may send a letter if you don't want to cut up the mag.

The telephone Hotline is getting very jammed after a new issue comes out, so bear with us if it's engaged. If all else fails - write in!

BRILL 'N' FAB HOTLINE PRIZES!!

Whether you phone or write in, all names go into the voluminous bag to be drawn monthly. First out receives **£40 worth of software** plus a CRASH tee shirt, and the five runners-up receive three issues of CRASH free plus a CRASH tee shirt.

Others may try and copy us but the CRASH HOTLINE CHART is the one that counts - and you are the people that make it count.

YOUR VOTE IS EXTREMELY
IMPORTANT - USE IT PLEASE!

CRASH HOTLINE WRITE IN COUPON

Please use block capitals and write clearly!

Name

Address

Postcode

Send your coupon to: CRASH HOTLINE, PO BOX 10,
LUDLOW, SHROPSHIRE SY8 1DB

Big climber this month (no prizes for guessing) is Ultimate's *Sabre Wulf*, which entered suddenly last month at 29 and now fights it out with sister program *Atic Atac*. Just below, another battle has been going on during collation between *Code Name Mat* and *Wheelie*, each swapping positions with each vote and *Wheelie* finally winning out. *Ocean's Pogo* has picked up nicely, slotting in at 13 a rise of 9 places from last month's 22 position. *Psytron (Beyond)* has made a good climb up 16 places to this month's 20 slot. *Blue Thunder* has also moved up 15 places to this month's 24 position (annoying no doubt for the person(s) who spent over half an hour on the Hotline telling us in graphic detail what they would do to us if it made Number 1!). A 19 place climber is *Mugsy* from **Melbourne House**. New appearances from *Moon Alert (Ocean)*, and two games with only a short voting time - *Lords of Midnight*, the new adventure from **Beyond**, and **Micromania's Kosmic Kanga**, in at 48 and 49 respectively. Nice to see new in the shoot em ups *Ad Astra* from **Gargoyle Games** and *Defenda* from **Interstella**.

PLEASE NOTE!

The CRASH HOTLINE is for recording votes only. There is no point leaving general magazine or mail order queries on it because the tapes are only monitored towards the end of a schedule for collation. Telephone numbers for other departments are listed in the Masthead on page 3.



My top five favourite programs in descending order are:

| TITLE | PRODUCER |
|-------|----------|
| 1 | |
| 2 | |
| 3 | |
| 4 | |
| 5 | |

CRASH HOTLINE SPECTRUM

SOFTWARE CHART

TOP 50 FOR AUGUST 1984

(Figures in parentheses indicate last month's position)

- 1 (1) **JET SET WILLY** Software Projects
- 2 (2) **MANIC MINER** Software Projects
- 3 (3) **ATIC ATAC** Ultimate
- 4 (29) **SABRE WULF** Ultimate
- 5 (5) **WHEELIE** Microsphere
- 6 (6) **CODE NAME MAT** Micromega
- 7 (4) **LUNAR JETMAN** Ultimate
- 8 (10) **CHUCKIE EGG A & F** Software
- 9 (7) **FOOTBALL MANAGER** Addictive
- 10 (8) **3D DEATHCHASE** Micromega
- 11 (18) **TRASHMAN** New Generation
- 12 (9) **SCUBA DIVE** Durrell
- 13 (22) **POGO** Ocean
- 14 (14) **THE HOBBIT** Melbourne House
- 15 (11) **FIGHTER PILOT** Digital Integration
- 16 (15) **JETPAC** Ultimate
- 17 (16) **FRED** Quicksilva
- 18 (12) **CHEQUERED FLAG** Psion
- 19 (17) **NIGHT GUNNER** Digital Integration
- 20 (36) **PSYTRON** Beyond
- 21 (19) **3D ANT ATTACK** Quicksilva
- 22 (24) **THE QUILL** Gilsoft
- 23 (13) **ANDROID 2** Vortex
- 24 (39) **BLUE THUNDER** Richard Wilcox
- 25 (35) **BLADE ALLEY** P.S.S.
- 26 (20) **VALHALLA** Legend
- 27 (30) **PENETRATOR** Melbourne House
- 28 (21) **PYRAMID** Fantasy
- 29 (25) **KRAKATOA** Abbex
- 30 (49) **MUGSY** Melbourne House
- 31 (44) **JACK AND THE BEANSTALK** Thor
- 32 (27) **ALCHEMIST** Imagine
- 33 (48) **PSSST** Ultimate
- 34 (—) **MOON ALERT** Ocean
- 35 (—) **SNOWMAN** Quicksilva
- 36 (45) **TRIBBLE TRUBBLE** Software Projects
- 37 (33) **MAZIACS** DK'Tronics
- 38 (43) **PHEENIX** Megadodo
- 39 (38) **URBAN UPSTART** Shepherd
- 40 (23) **SCRABBLE** Psion
- 41 (26) **ZZOOM** Imagine
- 42 (41) **TRANZ-AM** Ultimate
- 43 (—) **ORC ATTACK** Creative Sparks
- 44 (—) **AD ASTRA** Gargoyle
- 45 (32) **HUNCHBACK** Ocean
- 46 (—) **DEFENDA** Interstella
- 47 (—) **POOL** C.D.S.
- 48 (—) **LORDS OF MIDNIGHT** Beyond
- 49 (—) **KOSMIC KANGA** Micromania
- 50 (—) **COOKIE** Ultimate

VOTE for the CHARTS



This month's Hotline winner is **Sean Hawkyard**, Donnington, York. The four runners-up are: **Gordon Shennan**, Ayre; **Andrew Baines**, Llandudno, Gwynedd; **Mark Graymark**, Crawley, W. Sussex; and **A. Witchell**, Alveston, Bristol.

The winner of the Adventure Trail Hotline is: **Neil Gilleade**, Doveridge, Derbyshire, and the runners-up are: **Andrew Bowgen**, Wetherby, W. Yorks; **R. Graham**, London NW11; **B.J. Singleton**, Salisbury, Wilts; and **N.S. Wilson**, Shepperton, Middx.

CRASH ADVENTURE

TRAIL CHART

(Figures in parentheses indicate last month's position)

- 1 (1) **THE HOBBIT** Melbourne House
- 2 (2) **VALHALLA** Legend
- 3 (4) **ESPIONAGE ISLAND** Artic
- 4 (6) **URBAN UPSTART** Shepherd
- 5 (9) **INCA CURSE** Artic
- 6 (10) **MAD MARTHA** Mikrogen
- 7 (7) **ORACLE'S CAVE** Dorcas
- 8 (13) **MOUNTAINS OF KET** Incentive
- 9 (8) **PLANET OF DEATH** Artic
- 10 (20) **SHIP OF DOOM** Artic
- 11 (14) **BLACK CRYSTAL** Carnell
- 12 (30) **PIMANIA** Automata
- 13 (17) **INVINCIBLE ISLAND** Shepherd
- 14 (11) **GOLDEN APPLE** Artic
- 15 (3) **VELNOR'S LAIR** Quicksilva
- 16 (—) **GROUCHO** Automata
- 17 (6) **SNOWBALL** Level 9
- 18 (—) **FANTASIA DIAMOND** Hewson
- 19 (19) **LORDS OF TIME** Level 9
- 20 (18) **CIRCUS** Digital Fantasia
- 21 (—) **SUPER SPY** Shepherd
- 22 (—) **LORDS OF MIDNIGHT** Beyond
- 23 (12) **QUEST** Hewson
- 24 (26) **CLASSIC ADVENTURE** Melbourne House
- 25 (27) **TRANSYLVANIAN TOWER** Shepherd
- 26 (16) **COLOSSAL ADVENTURE** Level 9
- 27 (—) **TEN LITTLE INDIANS** Digital Fantasia
- 28 (15) **KNIGHTS QUEST** Phipps Associates
- 29 (29) **PHAROAH'S TOMB** Phipps Associates
- 30 (—) **DENIS THROUGH THE DRINKING GLASS** Applications

PLAYING TIPS

I thought things were bad enough when I only had the CRASH FORUM letters to worry about! It's getting hard to see out of my little window with all the letters piling up! Still, it's fun to read all your tips and sorry for all those I can't get round to putting in. Please note that at the time of writing, most if not all the tips or POKEs have **not** been tested by anyone at CRASH, so it's down to you to find out if they work or whether they are hoaxes. Talking of hoaxes, the trailer in *Lunar Jetman* does not exist, and as the man-made monster possible in *Atic Atac*, that too seems to be a cruel joke (pity really)!

Anyway, ever onwards. We'll kick off with an unusually honest writer...

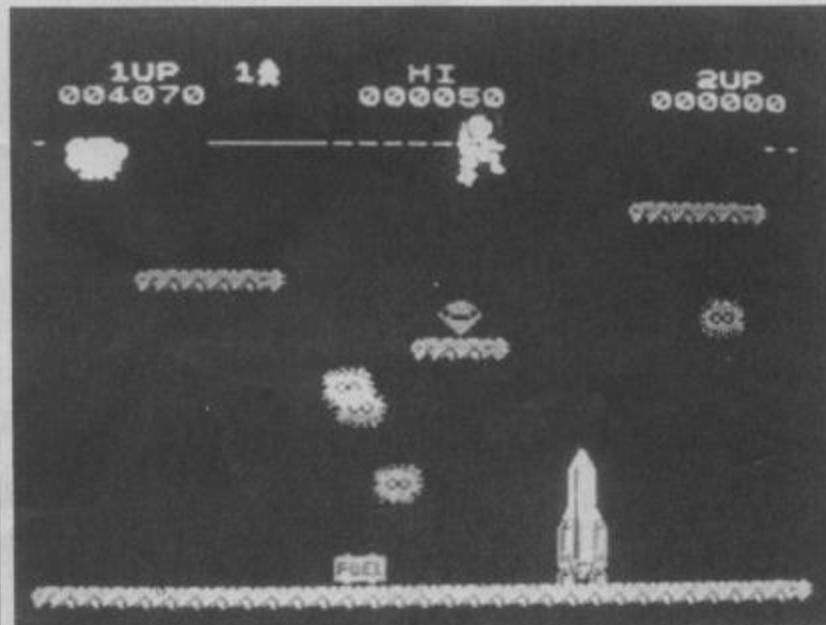

Jetpac— so far on this game my highest score has been over ten million. It took me nearly two weeks, leaving the Spectrum on overnight. At one time I had 45 men which was around the letter R or S in the alphabet (after 9 the men change to symbols then letters). What I did though was **not** cheat! Not like so many others by standing on one of the platforms and sheet 4 and allowing the planes to crash into it, thus gaining thousands of points. **NO**, on the contrary, what I did when I left it on overnight was to reach the fifth sheet and position jetman on the top right platform until six aliens gathered beneath him. Then if you leave him, nothing happens— you don't gain points and you don't lose them.

Steve Lea, North Anston, Nr Sheffield.

*What a refreshing change, someone who doesn't cheat!
Of course Sabre Wulf has*

resulted in a rash of tipsters. Certainly the earliest was by phone from Chris Colesell of Littleworth, Stafford who rang to say he had worked out of POKE which gets rid of any monsters which materialise (ie. it leaves the hippos and natives and the wulf). Since we have a policy here not releasing cheat POKEs too soon, I can't print it (do I hear the gnashing of teeth!), but perhaps some of you have already worked it out. It does work and has been put to good use in the CRASH mapping dept. Thank you Chris, and for your trouble we will be sending you the software you suggested you would like. Chris goes on to say:

When you are not using your sword, put it away as you run faster without it. Do not attack the gatekeeper or the wolf as they automatically kill you. If you find the bottom right corner in the second pit you can nine times out of ten find the other part in the second clearing up to the left of the mountains.

Neil Gore of Maghull, Merseyside writes:

The amulet is divided into four pieces. If you see anything flashing it's a piece. The small statues are extra men. The natives, hippos, rhinos and warthogs cannot be killed but can be made to move. The wulf cannot be killed and your best bet is to run away, but don't get trapped in a corner. Red orchids make you invulnerable for a short while and you can walk through

large open spaces (says **Richard Barker of Yeadon, Leeds**). Have your sword out at all times. If in trouble through lack of men wait beside an orchid for it to bloom blue, red or purple and keep changing screens to avoid the fireball. Look out for the small red doll shaped things— they're extra men.

Richard differs from Chris Colesell in the use of the sword. As to the possible positions of the amulet pieces, M. Smith of

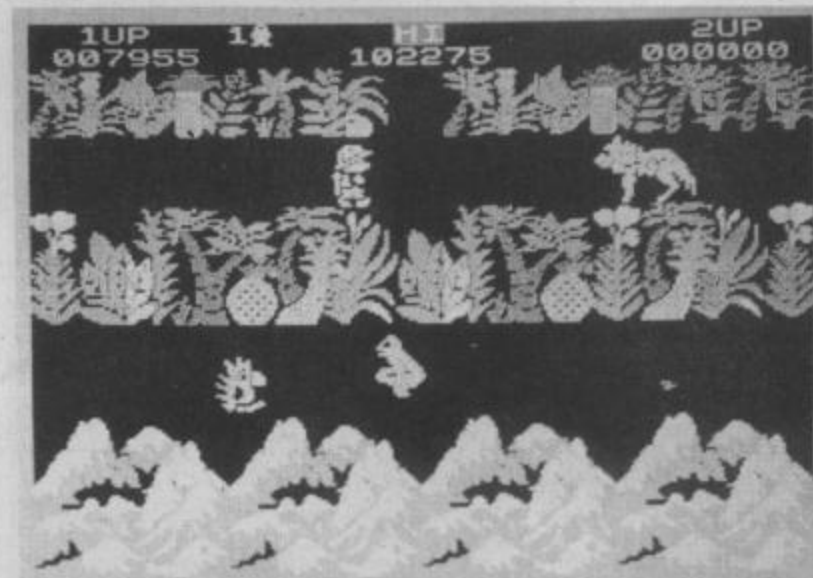
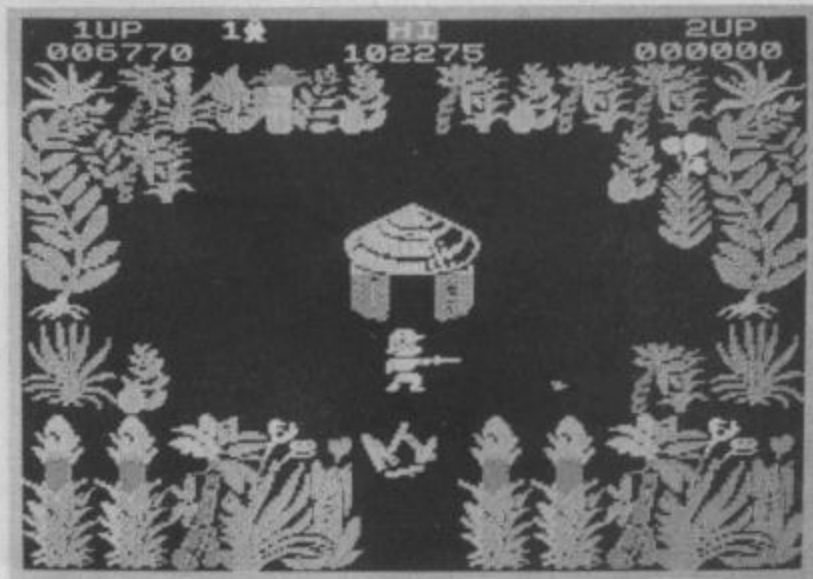

inhabitants but your speed is reduced. Blue orchids make you super fast, purple make you lose your sense of direction (all keys reverse action), white orchids change you back to normal.

I found the best way of avoiding the wulf was to dive upwards into the first possible pathway (put the sword away for extra speed as the wulf is faster than you are). Be careful when you re-emerge!
LM

The parts to the amulet are always in totally random places, usually in

Loughborough, Leics. (who claims to be the first to complete Sabre Wulf on the 3rd June and confirmed by Ultimate to be the first claim they received) says:

The parts of the amulet are always found in caves (dead ends) or next to huts and as there are only a few variations of positions of the four pieces it is possible to calculate where they can be each time.

David Fortune of Bramley, Leeds suggests:

Extra lives are obtained by running

over the small voo doo dolls scattered about. As you can only have a maximum of 9 lives it's wise not to run over too many extras as you may need them later.

Well, so much for Sabre Wulf (for the time being no doubt) and onto something useless but fun.

Jonothan Blythe (no address given) comments on Reviewers' Competition runner-up Gary Bradley's remark wondering how Ocean managed to get three different blues into their logo. Jonothan says he can get six shades and encloses a small program. We took a close look at it and decided it could be improved upon, with a resulting 14 shades of blue (well some of them are a bit dodgy). Try this:

```

5 PAPER 0: CLS
10 FOR a = 0 TO 6 STEP 2
20 POKE USR "(Graphics A)" +
a, BIN 01010101
30 POKE USR "(Graphics A)" +
a+1, BIN 10101010
40 NEXT a
50 FOR g = 0 TO 30 STEP 2
60 READ p,i
70 PAPER p
80 INK i
90 FOR a = 0 TO 21
100 PRINT AT a,g; "(2 * Graphics
A)"
110 NEXT a
120 NEXT g
130 DATA 0,3,3,4,5,3,5,2,1,2,3,1,
0,5,0,1,1,5,5,7,1,7,5,5,1,1,4,1,
0,7,0,0
150 INK 7: PAPER 0
    
```

Good grief, we're turning into a listings mag! Anyway, Jonothan, try that one out, it looks quite pretty!

Richard Van der Leeden of Mortimer, Berkshire has an interesting tip for Penetrator players:

If you go into training mode on Penetrator by Melbourne House, it will ask you which stage you would like to train on (1-4). If you enter 5 you will go to the fifth stage with the alien base!

Andy Clark of Norwich, Cheshire has also discovered this but goes on to say:

The landscape editor is really great. I have numerous landscapes saved on tape and can load them any time after loading the game. It also lets you add or take away missiles and radar scanners which can make the game much more easy or difficult. Keep up the good work with Britain's finest Spectrum magazine.

Mark Smith (14) of Norwich, Norfolk in keeping with **Rupert Loughton (15) of Wheaton Aston, Staffs, John Shields from Hayes, Middx**, and many others sent in up to eight codes for Wheelie by Microsphere:

2 = WITTY, 3 = SHARK, 4 = BEBOP, 5 = XENON, 6 = ZX83B, 7 = 2MQL3 and 8 = HRME2. Are

there any more? **Kris Hammond from Whitchurch, Bristol** also had eight codes in his letter but went on to say:

Another useful tip to know is the function of not burning any fuel. This is done by going as slow as possible, so that your speed and rev counter are both level at the minimum. This way you will not lose any fuel. It took about a month to find out.

Well at that speed I'm not surprised! Surely this makes Wheelie a bit boring to play though?

Colin Glaister (13) from Lowton, Nr Warrington wrote in (again alongside many others) to point out that the tips for accessing any room in Manic Minor we printed, were only for the original Bug-Byte version. He says:

To achieve the same effect on the Software Projects version of the same game the word TYPEWRITER must be typed in whilst holding down the 9 key. The screen codes are then the same except that where a 6 appears in them a 9 should be pressed instead.

Matthew Smith (Manic Minor and Jet Set Willy) obviously has a tidy but reversible mind. A similar procedure may be used on Jet Set Willy as **David Fenson of Lutterworth, Leics**, and many others have discovered:

Go to the bottom of the stairs in the First Landing and type in the word

WRITE TYPER. Then press a combination of keys 1-6 with 9 and you will now appear in a different room. For example, 9,1 puts you on The Bridge and 3,4,9 puts you on The Tree Top. From then on you needn't go back to the First Landing to make your jump. However, when you jump, make sure you position Willy carefully, otherwise he may end up in a wall or in thin air.

Steve Lightfoot (14) from Cheadle Hulme, Cheshire writes in with the same information and adds the POKEs published in last month's issue which rids the Attic of its chain reaction bug, but adds:

The best way to get to the Conservatory Roof is to start a new game - don't move Willy. Press 3, then 9 (The Drive) and then 6. Keep these keys down. You should now be transported to A Bit Of Tree. Keep the keys down until you are just above or on the top ledge. When you are on the ledge, jump up. You should be in Under The Roof. Now move left.

I can now do JSW thanks to these methods. To finish you will need 83 items. As soon as you touch the bed in the Master Bedroom, you go running back through the Top Landing and into the Bathroom, your head goes into the toilet and you wave your legs!

Onto Firebirds (Softek): Load the first two parts then break, edit the line and type POKE 24164,n (up to 255!) before the RANDOMIZE USR statement.

BACK NUMBERS

We can now offer a limited number of Back Copies to readers who may have missed out on

CRASH issues

95^p each

(includes postage)

Don't wait - they're in short supply!

Please send me CRASH issue No. _____

Name _____

Address _____

Postcode _____

I enclose £ _____

BACK NUMBERS CRASH PO BOX 10 LUDLOW SHROPSHIRE SY81DB



PLAYING TIPS

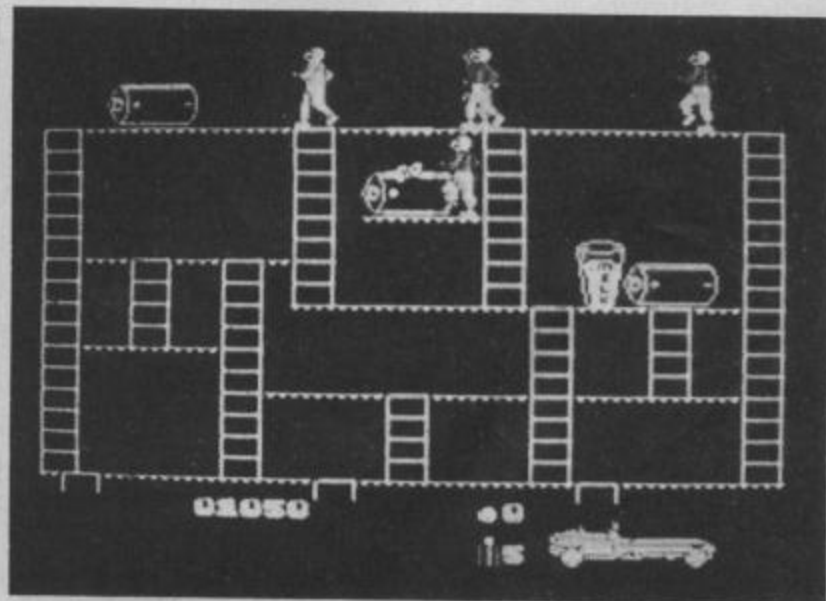

Jon Ritman, the author of Artic's Bear Bover, wrote in answer to the letter from Michael C. Shepherd (issue 5 page 30):

The mistake he seems to have made is to accidentally switch into BABY BEAR MODE before he started (it's meant to be for babies!). Michael probably didn't notice until round 5 due to his frantic attempts to avoid the BEARS. I suspect he was in this mode when he made it back to round 1 as I have never got past round 8 in BIG BEAR MODE (any extra baddies only appear in Big Bear Mode). As far as the guest star after BOVERBOT (who is this Jetman??) I'm afraid I can't help as I've never got far enough. My highest round black thing (with included hole) is 140,000 and I would be interested to know if anyone can beat this!

Chief Boverer, Jon Ritman, London N13.

Before we go on to the Hall of Slime, here are two letters on the subject. The first is from someone who signs himself **The Dolphin (friend of Ziggy)** who comes from Renfrew:

I find the claim of Mark Ellis of Cleveland hard to swallow, in that he scored 147,000 ODD in Pyramid. Anyone who has toiled with the flapping dustbins, mutant strawberries and the psycho cycles will know that any score over 145,000 is practically impossible. Unlike most shoot em up games Pyramid has a max possible score of 149,985. So how about a more accurate system of accepting these claims, like asking for the hi-score codes?

Well not every game provides a hi-score coding system for one thing and for another it would mean manufacturers providing us with those codes so we could check them, which might be a bit complicated! No, I think until the state of technology catches up with us for score verification, we'll just have to rely on your honesty in these matters, as the next letter suggests!

Let me start this letter by thanking you for printing my hi-scores in your Hall of Fame (you've got us mixed up with another mag - ours is a Hall of Slime - LM) but then you had the cheek to suggest that the scores had no way of being true (well you made that impression). I'm not saying that people don't lie about their hi-scores because I know a few who do (sorry Neil). But in all I think your magazine is ace and I haven't missed one issue of it.

Richard Avent, Downend, Bristol.

Lloyd Mangram's

HALL OF SLIME

Chuckie Egg 415,830 on L32
The Dolphin, Renfrew

Sabre Wulf 76,190 and 45% with 2 pieces
Neil Gore, Merseyside

Sabre Wulf 199,965 and 98%
L. Rain (14), Kidderminster, Worcs.

Ocean Kong 628,600
Graham Ashmore, Colwyn Bay, Clwyd

Pyramid 124,598
Neil Ward...
Hunchback 4,000,000 and **Orbiter** 1,034,000
David Baxter, both from Colwyn Bay, Clwyd

Atic Atac 2 minutes 26 seconds
Bugabo 19 seconds by
S. C. Fryer, Plymouth

Bear Bover 140,000
Jon Ritman (he what wrote it)

Atic Atac 3 mins 52 secs, and on
Chuckie Egg 580,190 on L40
John Redger, Fife Scotland

Sabre Wulf 133,970 and 99%
Zzoom 260,730 with 18 waves
Ant Attack 45,284 and 10 people
Psst 30,065
Bear Bover 12,000
P. M. Devereau, St Albans

Lunar Jetman 414,000 on L99
Simon Wright, Sheldon, Birmingham

Sabre Wulf 97,420 and 67%
James Earle, Harrow, Middx

Chuckie Egg 394,660 on L31
Daniel Beanland, Oakham, Rutland

Sabre Wulf 92,955 and 74%
Andrew Hawkes, Sheepy, Kent

Sabre Wulf 153,530 and 87%
R. C. Hambrow, Taunton, Somerset

Sabre Wulf 158,045 and 82%
A. Seymour, Perran Porth, Cornwall

Tribble Trouble 18,380
Adam Thomson, Shoreham, W. Sussex

Trashman 27,358
Lunar Jetman 300,000 on L22
Kevin Fitzgerald, London E4

Hunchback 1,485,100
Deathchase 87,777
Monsters in Hell 1008 (kills)

Chuckie Egg 271,960
Time Gate 12,600 (L5)
Trashman 10,379
Moon Alert 14,780
Wild West Hero 30,325
Alan Grier, Ayrshire, Scotland

That's it for this month. Keep the scores coming (and climbing) and remember, honesty's the best policy, keep your teeth clean, wash behind your knees and you too could become a hi-scoring freak and climb to the TOP of the RAM.
LM

Now's your chance to get into the battle zone with this exciting new 3D game from Realtime which has caused a stir among reviewers!

100 COPIES OF TANK DUEL

All you have to do is answer some simple questions and send the answers in – a somewhat easier task than beating the enemy in TANK DUEL.



3D Tank Duel is the brainchild of Realtime whose three members are Graeme Baird, Ian Oliver and Andrew Onions. They are all aged 21

and met at Leeds University three years ago while studying computer science. Ian and Andy have now graduated and are running Realtime full time. The firm's name, it seems, was thought up on a 125 intercity, as was the final name of the game, while dashing to appear at a ZX Microfair!

The third member, Graeme, due to a series of spectacular failures – not least being zero marks in his graphics exam – has taken a one year compulsory holiday. He has now passed the re-entrance exam and is continuing with his degree!

Tank Duel, their first release, was written in spare time over approximately six months (one month

OF TANK DUEL TO BE WON!



preparation, one persuading Graeme to do the graphics, one holiday, another persuading Graeme again and two months concerted effort).

Several more projects are under development including a multi-section 3D space battle game and some sprite games as well as a realtime graphics adventure. The latter is very much on the drawing board, but the 3D space battle is fairly advanced, and judging by some of the graphics we have seen, looks like being pretty amazing.

3D TANK DUEL COMPETITION

Send your entries, answers on a postcard (or outside of a sealed envelope), to **TANK DUEL COMPETITION, CRASH MAGAZINE, PO BOX 10, LUDLOW, SHROPSHIRE**. The competition closes on **August 30**. The first 100 correct entries drawn from the bag will each receive a copy of **3D TANK DUEL** by Realtime.

1. How many different types of enemy are to be faced in *Tank Duel*?
2. What was the name of the famous arcade original from which *Tank Duel* is descended?

3. What is the name given to the type of 3D graphics used in *Tank Duel* or any other game of this type?
4. How many triangles make up the graphics below?

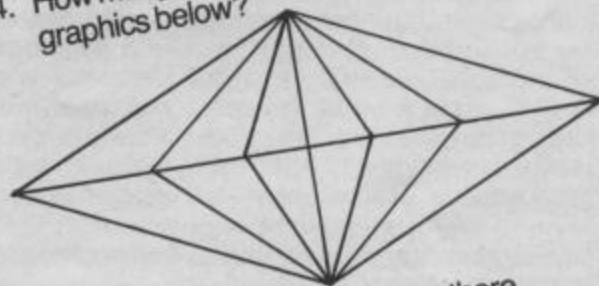

5. And how many triangles are there in this Tie Fighter?

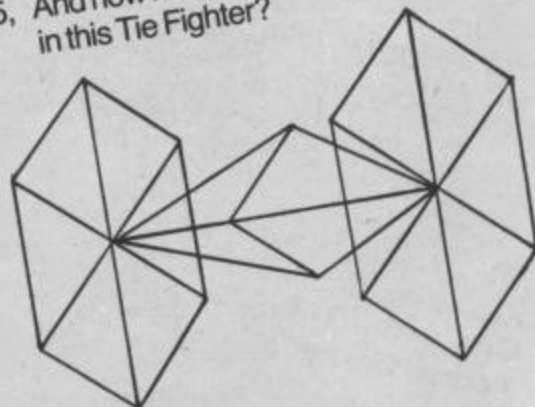

Gatecrasher

Producer: Quicksilva
 Memory required: 48K
 Retail price: £6.95
 Language: machine code
 Author: Dave Mendes & Tony Beckwith

'Has your keyboard melted away under the heavy artillery?' says the inlay on this new brain teaser. 'Do you have nightmares about swooping birdmen? Well, if so, this is the game for you. It has none of these.'

This seems a little censorious of Quicksilva, who are responsible for having swooped with many a birdman in their time, and brought much heavy artillery to bear as well! *Gatecrasher* is, simply, a brain teaser about gates and barrels. Basically you have to guide a number of barrels through a maze to make them land in one of the nine boxes at the bottom of the maze. In the maze there are gates placed at 45° which change their angle every time a barrel passes them. This makes it essential to study the path through the maze for each barrel respective to where you want it to go – and do this very carefully. The barrel dropper at the top of the screen may be moved left and right along the top to let you drop a barrel into any of nine apertures. Additionally, the pathways of the maze with their gates, may be scrolled vertically to create alternative routes through. You are given 20 barrels per level and there are seven levels.

On levels 1 to 4 you are to place a barrel in each box, on levels 5 and 6 you must sort the box numbers into order, and on level 7, place a barrel in each box again. Level 7 may only be reached after completing all the previous levels and achieving a

score of at least 15,000 points. On completion of level 7 the player is presented with a code to break and a chance of winning £200. During the game you may cause an earthquake which costs you one barrel per quake, but it rattles the gates and alters their present angles at random, which may be a help. Odd numbered levels tend to present easier mazes and even number levels are harder. There is no time limit.

CRITICISM

● '*Gatecrasher* is a strategy game, and the idea and layout is fairly simple, but it's very effective. I found the game to be both absorbing and challenging. The graphics are good, though simple like the game. I've a feeling this could become a sort of cult game – remember the Rubic Cube?'

● '*This is really a thinking game – no fast reactions or luck are needed here! I think a game like this might appeal to an adult market, where forward planning is a must. All the graphics move very well. Perhaps it should be played with two people as it can become boring playing alone.*'

● '*Gatecrasher* is a triumph of simple ideas over complexity. It is a classic puzzle game, and uniquely something for the computer, unlike so many attempts to translate traditional 'solitaire' games to the small screen. It is an example of that

old favourite question about how many grains of rice would you end up with if you started with one grain on square one of a chessboard, two on the second, four on the third and so on. The resulting figure is staggering of course, almost unbelievable. *Gatecrasher* has those sorts of combinations possible in what looks relatively simple at first. The game has excellent on-screen instructions and requires no playing skill – just brains and a good eye! I thought it was fascinating and extremely playable.'

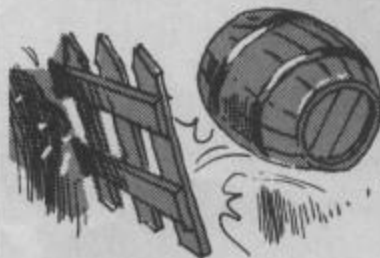

COMMENTS

Control keys: user-definable, two needed for left/right and two for scrolling maze up or down, one to fire the barrel on its way
Joystick: Kempston, although most other via UDK

Keyboard play: hardly essential, but responsive

Use of colour: average, although use well

Graphics: simple, effective and with very smooth movement

Sound: simple tune, useful noises, otherwise not much to be heard above the whirring of the brain

Skill levels: 1

Lives: 20 barrels

Originality: very original and unique to the computer

Features: a competition which closes December 3, 1984

General rating: if you enjoy puzzles, then this is excellent, perhaps a little pricey overall.

| | |
|---------------------|-----|
| Use of computer | 73% |
| Graphics | 67% |
| Playability | 75% |
| Getting started | 80% |
| Addictive qualities | 73% |
| Value for money | 78% |
| Overall | 74% |

Sand Scorchers

Producer: Unique
 Memory required: 48K
 Retail price: £5.99
 Language: machine code
 Author: Philip Carlin

Despite the cover, which might just tempt you to believe this is a game like Ultimate's *Tranz-Am*, *Sand Scorchers* is a Tron-style cycle game for one player against the computer or two players. Instead of the more usual ultra-thin light trails, there are character block-wide colour strips. The computer starts with one black trail from the top left edge, then it adds a blue one from the top right, then a red from the bottom right and so on, getting more difficult with each level. There is only one playing speed.

The object, as usual, is to 'drive' around avoiding contact with a trail of either an enemy or yourself, not driving off the edge of the screen or reversing on your own trail. The winner is the one to force the enemy cars into a spot where they have nowhere else to go.

CRITICISM

● 'I really like to see interesting and exciting covers and feel they should be encouraged. But what does spoil things is that some games look great on the outside and don't leave the same impression once loaded. This is typical of that variety – a spectacular sand buggy/explosion followed by a line blocker type game (Tron). The game was fast, almost too fast for keys and the graphics were simple. A fairly typical example of this type of game. Not what I expected and not too hot anyway.'

● '*I am not at all impressed with this game – primitive idea and primitive graphics. This is the sort of game I would have expected two years ago. There is some sound, but not much colour. Overall a very poor standard on a high software standard machine. Don't buy it.*'

● 'This is the most enjoyable game of its type I have played, perhaps because the wider stripes of colour, or trails, make it easier to see what's going on. Having said that, I couldn't re-

Uniquely a computer puzzle, *Gatecrasher* demands concentration although it looks simple enough...

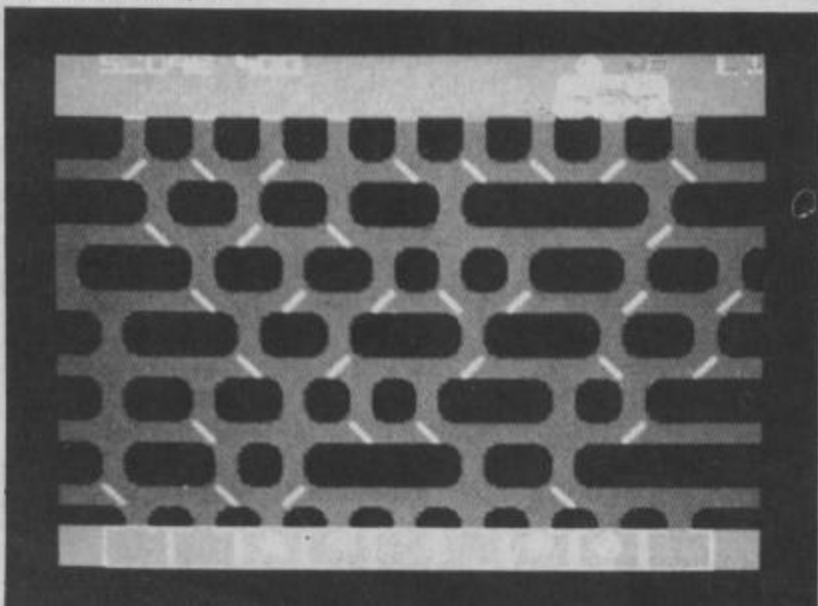

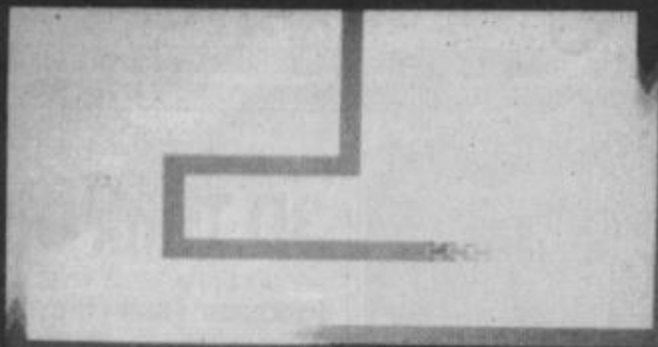

P1: SCORE=307 LIVES=1 LEVEL=2
P2: SCORE=0 LIVES=4 LEVEL=3

After the cassette cover, the graphics are a let down – not much sand scorching here.

commend anyone to fork out money for this unless they are dead keen on Tron type grid games. There are so many versions available (though this is reasonably good) and the game must have gone out of fashion months and months ago. Also, the packaging is extremely misleading, with its racing, exploding picture on the cover and the blurb inside which says, 'Whilst driving your sand-scorcher across the desolate wilderness you come under attack from other hostile sand-scorching buggies.' Sounds great, doesn't it? The game looks nothing like the description at all. Control responses are reasonable which isn't quite good enough for a game of high speed reaction such as this.

Joystick: Kempston, Fuller, Protek, AGF, ZX 2
Keyboard play: reasonable, good because of UDK
Use of colour: poor
Graphics: primitive
Sound: simple tunes and none during play
Skill levels: 12
Lives: 4
Originality: hardly any
General rating: poor to fair

| | |
|----------------------------|-----|
| Use of computer | 70% |
| Graphics | 25% |
| Playability | 45% |
| Getting started | 55% |
| Addictive qualities | 38% |
| Value for money | 40% |
| Overall | 46% |

COMMENTS

Control keys: user-definable, four directions needed

World Cup Football

Producer: **Artic Computing**
Memory required: **48K**
Retail price: **£6.95**
Language: **machine code**
Author: **D. Campbell**

Since Kevin Toms and Addictive Games proved how popular football game simulations can

be, there have been several contenders for the 'cup. Most concentrate on the strategy angle – the management of a team. Only once has a game been released which is actually a graphic representation in which the player(s) control the actions of the team on the screen, and that was *Star Soccer* by Watson (no longer available).

Now Artic have released *World Cup*. This game has no strategical element, no selection of players according to their

strengths, skills, temperaments etc., no juggling with banks or balancing books. *World Cup* is just football, the game. Owing to the difficulty of coping with a number of large characters on the screen with the Spectrum, there are not eleven members in the opposing teams, only five plus the goalkeeper.

World Cup may be played by one player against the computer or two players simultaneously against each other. The program also allows between 1 and 9 players to select teams they want to represent and will keep score and run the championship. A pool of 40 World Cup teams is provided to choose from.

The screen shows only a portion of the playing pitch, approximately the centre third, but scrolls left or right with the action to either end's goal. In the background, atmosphere is provided by a wildly waving, cheering crowd, while the continuous soundtrack plays all those ghastly old football crowd favourites! As with *Star Soccer*, the computer constantly monitors the action and will take control now and again, moving the influence of action from one player to another on the field as appropriate, taking corners, goal kicks and throws automatically. Otherwise the player has full control over the actions of a player in possession of (or fighting for) the ball.

CRITICISM

● *World Cup* is an interactive game, nowhere near as involved as *Football Manager* when it comes to strategy and decisions, but it does have player involvement in the matches, and is the only one as far as I know for the Spectrum in which you actually move and control the players. The graphics are quite good, and the game is reasonable. The actual football play is okay but not up to the

standard of such games for other machines. Nevertheless, its uniqueness makes it good, and it's great as a two-player game.'

● 'There have been plenty of football games before, but you've never been able to join in with the fun properly before. In this game you play the part of an entire team, actually playing – great! Playing against the computer is fine, playing against someone else is even better fun. All the players move well, up and down the field; the man that you control is very responsive, so a good simulation can be achieved. Detail such as crowds waving and football tunes are great. This is the best interactive football game for the Spectrum and football fans should get it!'

● 'I'm sure this is likely to prove a popular game, especially for those who like football and like playing it. Artic have certainly done a good job considering the difficulties on the Spectrum with colour attribute problems and overlapping characters. This is the one area where it fails for me a little. In a tackle it is hard to see what is going on and sometimes hard to tell whether you have the ball or not. There are loads of different tunes being played to add to the atmosphere, although they can be switched off if they're driving you crazy. Nice detail too, when a match starts and the players run out from the tunnel or when they change over sides at half time. Pretty good.'

COMMENTS

Control keys: well placed for two players – (1) 1/Q up/down, A/S left/right – player (2) D/O up/down, J/K left/right and bottom row to fire for both
Joystick: ZX 2, Kempston
Keyboard play: responsive
Use of colour: used well with control players altering colour

Real live action on the scrolling screen of World Cup.

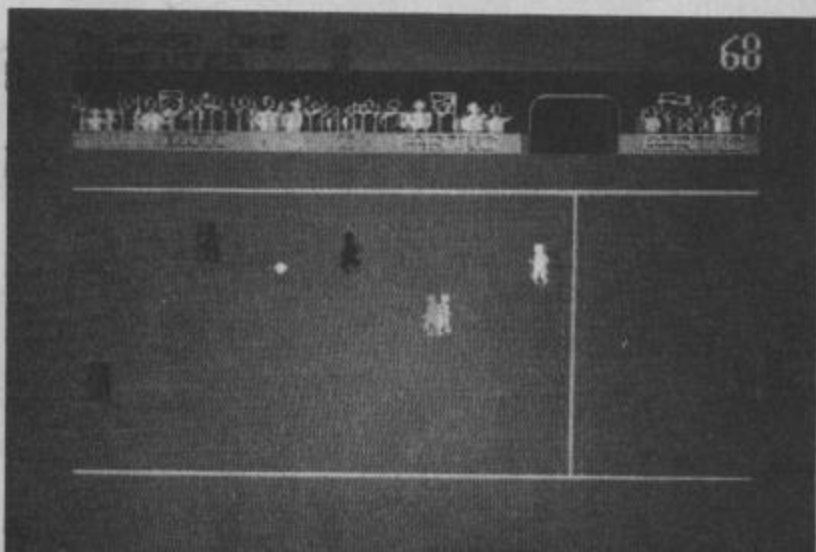
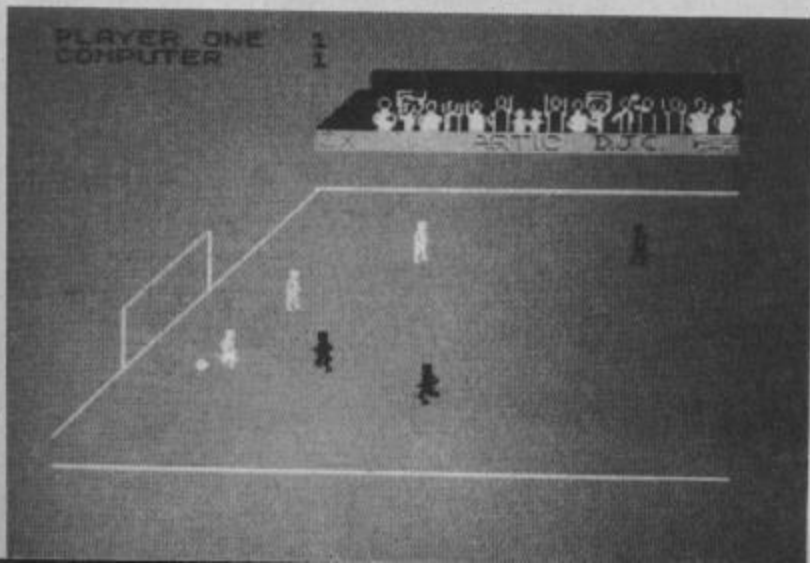

for indication

Sound: very good, continuous tunes with on/off facility, whistle effects

Skill levels: 1

Originality: as far as the Spectrum goes, very original

General rating: generally above average but good of its type.

| | |
|---------------------|-----|
| Use of computer | 68% |
| Graphics | 72% |
| Playability | 73% |
| Getting started | 70% |
| Addictive qualities | 77% |
| Value for money | 68% |
| Overall | 71% |

Virus

Producer: **Orange Software**
 Memory required: **48K**
 Retail price: **£5.95**
 Language: **machine code**
 Author: **Simon Johnson**

Orange Software is very new and this is their first program, accompanied by a letter betting we couldn't even get off the third level. Well we did – so there!

The setting for *Virus* is New York. New York in this case is a purple coloured maze and it has been struck by a dreadful virus which is not only killing everyone off, but mutating the bugs the city is famous for into horrific man-eating things. Your job is to save the place by collecting Culture Moulds and taking them to the laboratory. The levels of the game are split into 'suburbs' of New York – New York, of course, looks the same whichever neighbourhood you're in. On each level you have to collect five moulds. The mould, a white object, dashes around the maze with a life of its own. Once collected, the lab in the centre of the screen flashes and you can dash to it. Once five moulds have been thus deposited you move to the next level. To make life difficult there are several types of bug. The green ones drain your energy and eventually kill you off, red and yellow ones kill on contact. As the game progresses on each level, blue axes and red food appears. Axes save you from the bugs and banish them for a few moments, the food replaces lost energy. Finally, the centre track contains a speeding centipede like a subway express, which moves from left to right at random but frequent intervals.

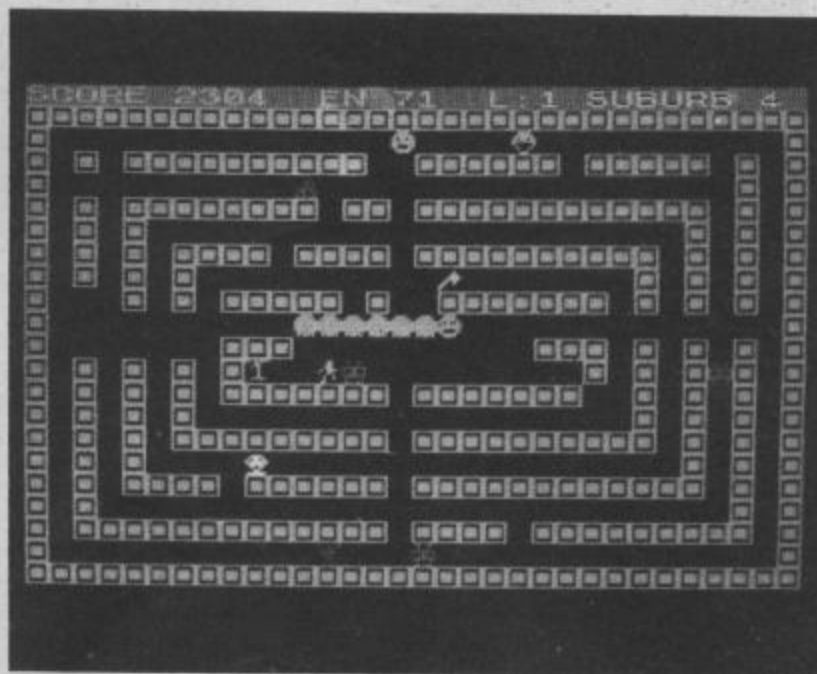

Axes, monsters, centipedes and moulds make for an unusual game. The culture mould is the brighter diamond shaped thing lower left.

CRITICISM

● 'If you want a super-smooth graphics game, don't buy this one. On the other hand if you want a fast, zippy and colourful game which is above average, then read on. *Virus* is not super enough but it is a nice variation on the pac/centipede theme. It's fairly playable and fairly addictive and gets better with each game. On the whole not bad at all.'

● 'It's surprising to find maze games like this still being developed, because the concept is so old-fashioned. But this one does have many original features. Graphics are one block and don't move very smoothly, but then again, who cares with a game like this – it's fun in itself. There is a certain amount of simple animation in these very fast moving graphics. The objects are easily recognisable, which is a must in these types of game where the collecting of objects is the point. Colour is used well and all the characters are shown up very brightly. Sound is continuous with good squelches and various other good sound effects. I think this game is quite playable, but after a while it tends to get repetitive, as do most maze games.'

● 'I suspect the proprietors of Orange Software are quite young, judging by the letter which accompanied this tape. Their bet about the third screen was soon undone, at least on the two slower levels (there are 4). But the game gets progressively more difficult, with more bugs being added, and what

starts off as a relatively ordinary looking maze game does develop into a pretty fast and interesting one. Colours are bright and the graphics, although jerky, are fast moving. There is an unusual but sensible keyboard layout. I found it playable and reasonably addictive, but eventually lacking long playing appeal.'



COMMENTS

Control keys: Q/A up/down, B/N left/right

Joystick: Kempston

Keyboard play: responsive

Use of colour: well used and bright

Graphics: small, reasonably detailed and fast

Sound: good, continuous

Skill levels: 4 speeds

Lives: 3

Originality: a very novel series of ideas based on several older themes

General rating: above average.

| | |
|---------------------|-----|
| Use of computer | 69% |
| Graphics | 59% |
| Playability | 66% |
| Getting started | 65% |
| Addictive qualities | 56% |
| Value for money | 57% |
| Overall | 62% |

3D Tank Duel

Producer: **Real Time**
 Memory required: **48K**
 Retail price: **£5.50**
 Language: **machine code**
 Author: **Ian Oliver, Andrew Onions, Graeme Baird**

We first reported on *3D Tank Duel* two issues back as a news item, of interest to us at CRASH because **Andrew Onions** is a local Ludlow person (although **Real Time** operate from Leeds), and then again in the last issue's 3D article. Now we have a real production copy in its glossy black and silver cover (no hype here!) which incorporates a few improvements on the preview copy first seen.

Tank Duel is in the tradition of 'Battle Zone' type games which use 'wire frame' or 'hollow' 3D, and on the Spectrum follows in the footsteps of Artic's *3D Combat Zone* and *Rommel's Revenge*. A person representing both Artic and Crystal was heard to remark to the people who produced this version that it was good but old hat. When you consider how many pac-men, asteroids and berserks have been released with all the hype and flurry of the biggies, arguing that a third version of something is old hat seems rather premature. But in the end it is down to our reviewers.

First off, our report that the game includes bikers drew snorts of amused horror from the programmers – they're supposed to be missiles – sorry!

The screen display is split into two areas, a black one at the top containing score, hi-score and radar screen with sweep arm, and the larger, lower area which shows a yellow desert landscape with black background, and on which the enemy materialises. A large squared gun sight dominates the centre of the screen. The game is played against four different types of tank, flying saucers and missiles (which look like bikes if you don't look properly). In addition to the enemy, the desert is littered with various shaped obstacles which impede progress if they are run into.

Two points incidentally: firstly only one reviewer was aware that one of the programmers is local (so no Ludlow chauvinism should creep in!); and secondly, the programmers' hi-score to beat at present is already 31,700!

CRITICISM

● '3D Tank Duel is the closest version yet to the real thing (Battle Zone). It contains the various tanks, missiles and saucers which explode into chunks and fragments when hit. The movement is very good. Generally this is a very good version of a good arcade game – it even includes new features like a more varied landscape, revolving radar dishes etc. This type of game is still very addictive even if it is one of the oldest arcade games about, and this is one of the best versions. The tanks are intelligent – they will dodge behind obstacles; also, watch out for the missiles that leap over obstacles making them hard to hit. Great graphics – as close to the original as the Spectrum could ever manage.'

● 'I thought that this was another Battle Zone rip-off type game – but no, it is the real thing but with more colour. There are six enemies of varying intelligence although the easiest tank is quite intelligent. Colour and a detailed city in the background has cheered the game up no end. All graphics are detailed in their own particular way, and the sound is the best I have ever heard for this type of game. If you like 'Battle Zone' then you will love this excellent copy of it.'

● 'If anyone thought 'Battle Zone' was played out on the Spectrum, think again. This is a highly playable, addictive and intelligent piece of software. This type of game usually plays quite slowly, but Tank Duel is fast – enemy tanks reappear on screen after shooting one much

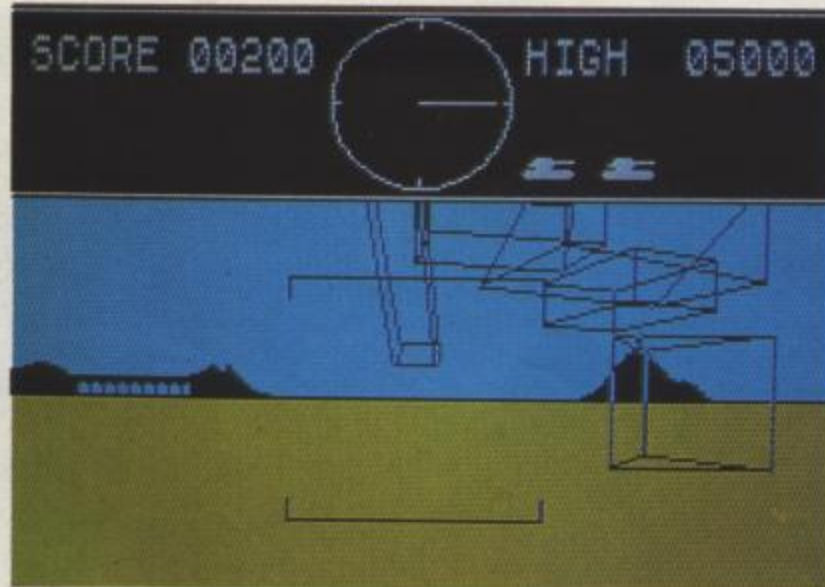

Good, blocky, realistic explosions

faster than any other game I have seen, and they move quickly on the screen too. The 3D effect works excellently. For instance, if you destroy a tank and the chunks fly up into the air, they will pass over your head if you drive forward, and retreat into the distance if you back off. Also, each tank explodes into its component parts in an individual way. Sound is well used, with a realistic grumbling noise of your engine ticking over, revving when on the move and idling again when stationary. The missiles are devilish to avoid, weaving as they approach at high speed and leaping over any obstacles in the way. They underline that the speed of these graphics are the fastest yet in this type of game. Very addictive.'

COMMENTS

Control keys: Tank Duel uses an unusual combination of keys to simulate the movement of a real tank, ie. left track forward and backwards, right track forwards and backwards.

Reviewers comment that although difficult at first to get used to, the effect is good

Joystick: Kempston, ZX 2, Protek, AGF

Keyboard play: responsive

Use of colour: limited by nature of game, but more varied than usual

Graphics: wire frame 3D with complex use, fast and smooth

Sound: well used and varied

Skill levels: 1

Lives: 3

Screens: continuously scrolling over infinite area

Originality: obviously not all that original, but the best version yet, and scores on trying to outdo the others in look

General rating: playable, addictive and very good value.

| | |
|---------------------|-----|
| Use of computer | 80% |
| Graphics | 86% |
| Playability | 83% |
| Getting started | 83% |
| Addictive qualities | 82% |
| Value for money | 81% |
| Overall | 83% |

An entire army of tanks to face..

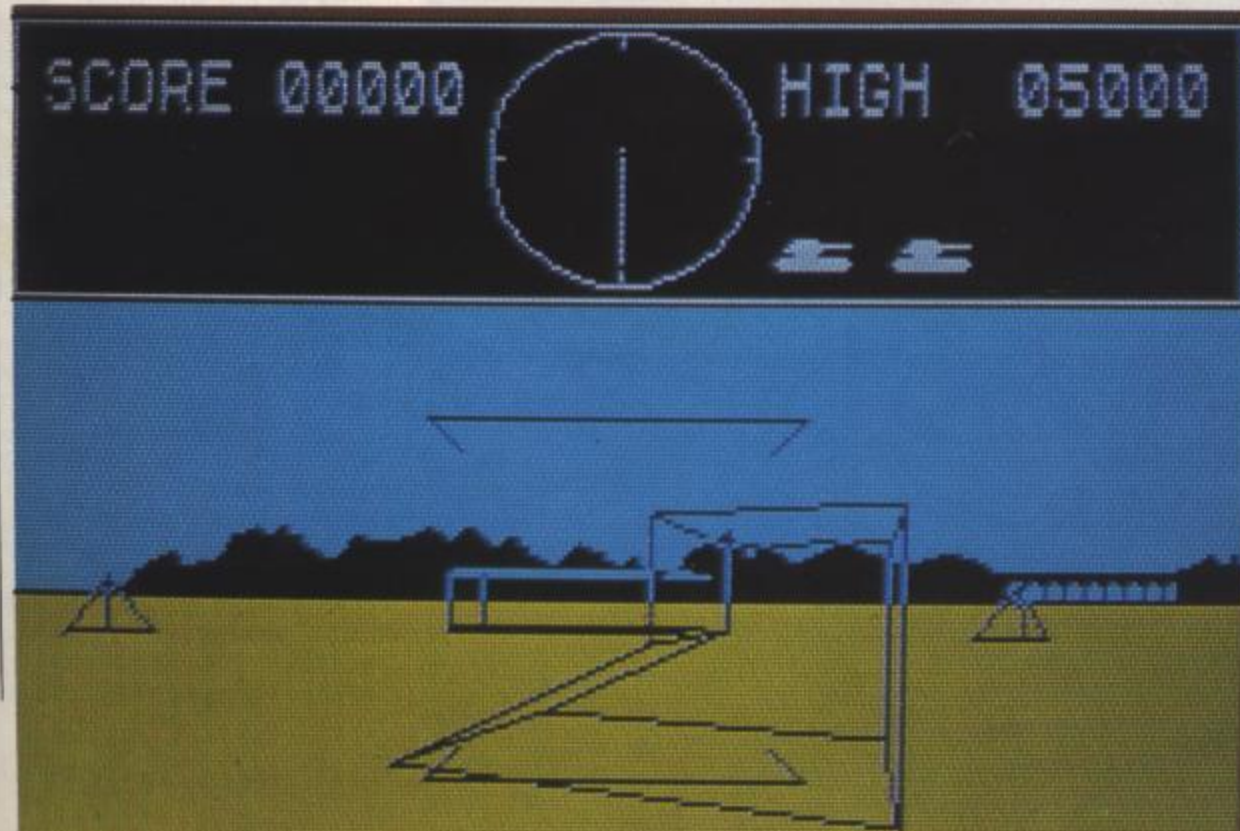

Cavelon

Producer: Ocean

Memory required: 48K

Retail price: £5.90

Language: machine code

Author: Christian Urquhart

Ocean have done rather well at taking British arcade machine games and translating them (officially) to the smaller screen. Cavelon is another 'official' version for the Spectrum and Commodore 64. The Spectrum version has been done by **Chris Urquhart** (Transversion and Hunchback) and sports an excellent title screen designed by **D. Thorpe**. Basically it is a large maze game, one screen high and several in width, scrolling as your man moves across.

Medieval themes are uncommon on the computer. Here you play the part of a gallant knight out to rescue Guinivere who has been imprisoned on the top floor of a tower. There are six levels to ascend and the only way to get from floor to floor is to collect all the pieces of the door which have been dotted around the maze. Knights and archers will try to stop you. They march around randomly all over the place. Your only defence is the sword Excalibur which renders you immune for a short time, and arrows. Where possible, Excaliburs should be saved up for later levels where they are really needed!

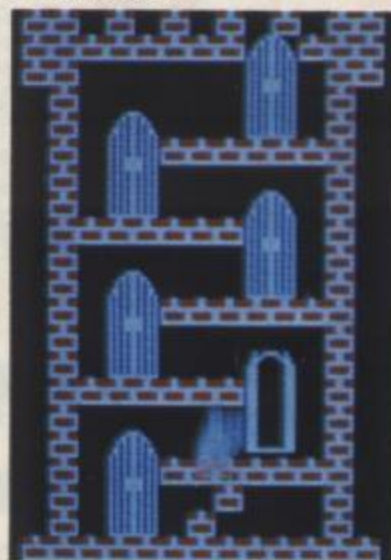

At the start you see your knight ride up to the castle, squeal to a halt and dismount from his steed and enter the castle. Between each level there is a screen showing your knight mounting the tower stairs to the next level. The playing screen is a square with a status panel to its right showing score, hi-score, bonus points

(achieved by collecting objects other than door pieces on the way), a red graphic of the door itself which fills in white with each piece collected, your lives, and Excaliburs available to you.

CRITICISM

● 'Cavelon is a difficult game to form an opinion on. I feel that it is one that you will either like or dislike (with no indifference). I enjoyed it and thought it was very good. The graphics are good, as is the sound (only a handful of Spectrum games have a tune running throughout, as this one does). On the whole, very good, but not quite in the Spectrum super league.'

● 'This must be one of the new generation of maze type games - it's a very simple idea but with plenty of playing appeal, content and action. The game is so simple an idea it just leads to compulsive playing. The whole structure of the game is most enjoyable. The graphics are quite colourful, they move quickly and smoothly. Sound is continuous with no on/off switch - this could drive you crazy. A good game and well worth buying even if it's only to see what's on the top floor!'

● 'I saw Cavelon first on the C64, by about a few days, and was impressed. So it was a pleasure to see it on the Spec-



Greensleeves and a hey nonny ho as you dash to the rescue.

trum, and an even bigger pleasure to find that this is one game which actually looks better on the Spectrum as well as playing better. The Spectrum version is a much tougher game and so more addictive. Although you are armed with arrows, I like the way archers when hit turn to knights and only a second arrow hit will get rid of them. A good looking game and an addictive one.'

COMMENTS

Control keys: S/X up/down, N/M left/right, A fire arrow, SYM SHIFT for Excalibur zap button
Joystick: Kempston, ZX 2 Protek, AGF
Keyboard play: good positions and very responsive
Use of colour: good
Graphics: good, smooth and well animated
Sound: effects with continuous medieval theme tune
Skill levels: each screen progressively harder
Lives: 3

Screens: 6 playing screens, 2 intergame screens
Originality: very good
General rating: addictive, playable and very good generally.

| | |
|----------------------------|-----|
| Use of computer | 78% |
| Graphics | 86% |
| Playability | 88% |
| Getting started | 87% |
| Addictive qualities | 88% |
| Value for money | 88% |
| Overall | 86% |

Beaky & The Egg Snatchers

Producer: Fantasy
 Memory required: 48K
 Retail price: £6.50
 Language: machine code
 Author: Bob Hamilton

As we reported a month or two back, Fantasy have given their super hero Ziggy a holiday, and in this, their new game, a new hero emerges - Beaky. Beaky lives on the planet Crackit, and the place is of the type that would give David Attenborough shivers of ecological pleasure. This is survival of the fittest. As Beaky your task stretches across three screens of furious activity and the aim is to raise more Beakys like yourself. Don't worry - this is no sex



Above; the first screen. Below; the Froogle attacks



education game - Beaky's broody habits are restricted to saving eggs, hatching them and feeding the resultant chicks.

In effect there are 12 different screens, consisting of three distinct phases. The object is to rear four generations of Beakys to complete the game. Beaky is an Andromedan Condor and possessed of magical powers, he also spits magic seeds which kill off his aggressors. In the first screen the Eggsnatchers have robbed the nest of its eggs. These can be seen dotted about on the five platforms above the nest. Eggsnatchers keep materialising and then picking up the eggs. After a second or two they dematerialise with the egg. Beaky must fly around rescuing the eggs. Because they are too heavy to pick up, he must wait for an Eggsnatcher to get one, then shoot the beast before it dematerialises. The egg is dropped and falls, Beaky must zoom down and catch it before it drops and smashes, eventually landing on the nest to

deposit it. Contact with an Eggsnatcher will cause it to dematerialise with a resultant loss of some of Beaky's magical power. When all power is lost the game is over. On subsequent levels poison green eggs will fall into the nest. These are best shot out of the air as they destroy the already collected eggs one at a time. Leaving the first phase is up to the player and is a strategic decision. Too soon and you won't have enough eggs - too late and there won't be enough magical power to sustain you through the next two phases.

Having collected some eggs they must now be hatched out. For this they need warmth. Fortunately they only take two minutes to hatch. However life is made difficult by the snowflakes which keep dropping on the nest lowering the eggs' temperature. These may be shot at, in which case they turn to water, which has less effect. Another shot when the drop turns blue will vapourise altogether. If the temperature drops to zero an egg will be lost. On top of this is the Froogle (claimed to be a distant relative of Googly Bird from *Doomsday Castle*), which hops slowly along and flicks liquid nitrogen into the nest causing a drop in its temperature. Froogles are dissuaded from this unsavoury habit by shooting the spheres which float around and causing their central nuclei to fall on the Froogle's head. Contact with a Froogle causes severe depletion of magic power.

Successfully hatching out an egg takes you onto phase three - feeding the chick. This is accomplished by catching large quantities of a green flying worm and taking it back to the chick. The worms are not easy to catch, being naturally shy of vicious Andromedan Condors. More Eggsnatchers will appear in this phase (they also like green flying worms) and will drop missiles into the nest, further depleting any food you have already collected. Rearing a chick through this phase returns you to the first at a higher, more difficult level. Completing all four levels will result in a hi-score code appearing for Fantasy's Hall of Fame (as well as Lloyd Mangram's Hall of Slime).

CRITICISM

● 'This is one of those games which starts off fairly difficult and boring but gradually grows on you. I thought the graphics were

a bit of a come down after *Doomsday Castle* although the animation is quite good. Beaky has a mind of his own and is hard to control, especially when landing. The game becomes progressively more interesting. Colour and sound are well above average. It gets to be very addictive although I still think *DDC* was a better game, but certainly worth buying.'

● 'Fantasy certainly go in for games with a lot going on, and Beaky is no exception. There's a very long and amusing set of instructions with the game objectives and methods of play very clearly laid out. It's just as well, because Beaky is hard to get used to at first. The controls are simple and good, left, right, flap and fire, but he has an inbuilt instrument landing system which means he operates quite erratically (it seems at first). Once mastered, the game stops being unfortunately hard and becomes plain hard! The Eggsnatchers, particularly, are well designed and animated, and the graphics throughout are very good indeed. There isn't quite as much going on as in *DDC* but saving eggs is sweaty work. At first I thought the fact that you can exit phase one on your own decision lowered the playability and point of the game, but in fact its very much a case of too many or too few eggs. You have to be careful in deciding when to go on to the next screen. In the end I think Beaky lacks all the excitement and addictivity that *Doomsday Castle* had, but it's certainly a good game and very original and very playable.'

● 'After really enjoying Fantasy's last two productions I was really looking forward to this one. But I was somewhat disappointed with it. The game has great graphics (perhaps not quite as varied as usual) and it is highly original. It just didn't seem very playable or addictive to me. The bird is difficult to control so that you can get in good shots at your enemies. Perhaps Fantasy are trying to be too adventurous. Still it is above average to the point of being good.'

COMMENTS

Control keys: preset - O/P left/right, Q flap, M fire, E quit (to next level), but keys may be user-defined
Joystick: Kempston, ZX2, AGF, Protek
Keyboard play: very

responsive

Use of colour: very good

Graphics: smooth, large, detailed and very good

Sound: good noises, not too much of it

Skill levels: progressive difficulty

Lives: the magic you're given

Screens: 3

Originality: very original

General rating: quite mixed feelings between the reviewers

- we felt everyone was trying too hard to compare it to *Doomsday Castle* - which ranged from above average, to good, to very good. Generally recommended.

| | |
|---------------------|-----|
| Use of computer | 66% |
| Graphics | 83% |
| Playability | 70% |
| Getting started | 83% |
| Addictive qualities | 71% |
| Value for money | 75% |
| Overall | 75% |

Dotty

Producer: Dollar Soft

Memory required: 48K

Retail price: £5.95

Language: machine code

Author: R. Stevenson & P. Durbidge

Dotty is a pacman variant with three different mazes drawn in a 3D perspective. There is a dot gobbling orange, four multi-coloured ghosts and four power pills in the shape of the dollar sign. What makes this game different is that the mazes are not drawn with single dot-wide corridors, many areas are two, three even four dots wide. There are also 'rooms' which are dangerous to enter as there

is only one exit, also very long corridors with the attendant risk that you may get trapped.

The object of the game is quite traditional, eat up all the dots and avoid being eaten by the ghosts. After eating a power pill the ghosts turn blue and may be eaten in turn. Each maze is faster than the one before.

CRITICISM

● 'This is a 3D pacman variant. The 3D effect is quite good on the maze and does catch you out when the game speeds up into an impossible level. Graphics are small but colourful, and move quite smoothly. The large maze makes the game quite playable - as far as Spectrum pacmen go.'

● 'There are a few problems with this game, but I would have to say that I found it strangely addictive to play and one of the most enjoyable pacman type game on the Spectrum that I have played. The large mazes, each with a warp tunnel somewhere, are cleverly designed to make life quite difficult, especially, at the higher speeds. Added to this, the graphics are very good sprite animation, move smoothly and very fast. Colour has also been well used, especially on the 3D maze. This 3D does have a minimal effect, making it hard to get some of the dots. There are two very neat touches. When you start, your orange is nowhere in sight, but moving him up or down, causes him to appear from a wall as though materialising. And when he is hit by a ghost the effect is very good, about the closest to the original I have seen. The problems are control which is very sluggish on a joystick, better on the keyboard. Also the ghosts give no warning

First of three mazes with multi-dots in Dotty.

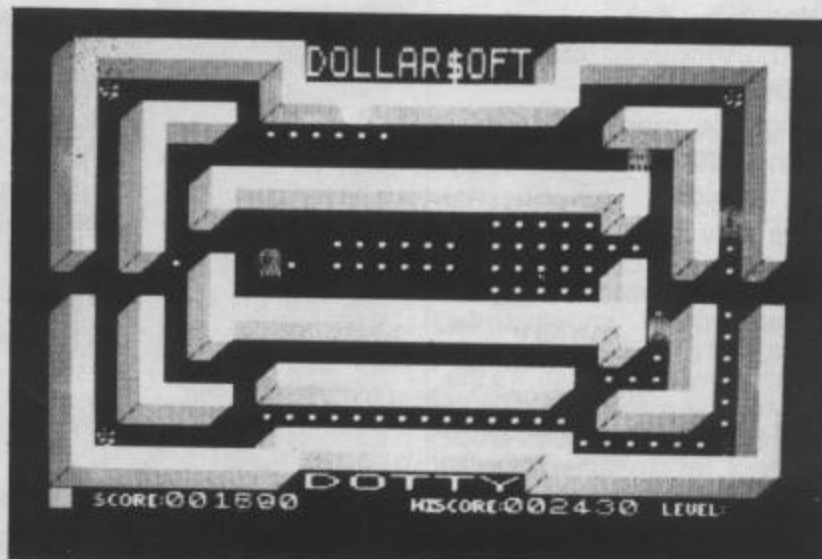

when about to change colour from edible blue to dangerous full colour again. If you eat a ghost it effectively reappears instantly somewhere else in the maze. There are no bonus fruit. Despite the control, I thought this was a pretty good version and well worth adding to the collection.'

● 'This version of the pill-popping arcader has very bright colours and is a close copy of the original - well quite close anyway. The orange being squeezed to death is the best copy of the original I have seen. But there are so many pacman versions around, I wonder whether this can compete.'

COMMENTS

Control keys: good positions, Q/A up/down, O/P left/right
Joystick: Kempston
Keyboard play: very responsive
Use of colour: very good
Graphics: small, one-character size, but smooth moving
Sound: average
Skill levels: progressive speed
Lives: 3
Screens: 3
Originality: the game type isn't original, but the variations are
General rating: a well paced, addictive pacman type, above average to good.

| | |
|---------------------|-----|
| Use of computer | 68% |
| Graphics | 70% |
| Playability | 69% |
| Getting started | 65% |
| Addictive qualities | 72% |
| Value for money | 65% |
| Overall | 68% |

Jack and the Beanstalk

Producer: Thor
 Memory required: 48K
 Retail price: £5.95
 Language: machine code
 Author: Steve & Chris Kerry

As a fairy tale, *Jack and the Beanstalk* is a celebration of a country-bred idiot making good through never knowing the limitations of his own idiocy - or perhaps, more fairly tale, it's the story of how mankind prefers to believe in the magical properties of things rather than in good solid common sense. Jack, of course, is the lad who



took his poor family's cow to market and on the way met a man who offered to buy it from him for a bag of magic beans. Though ostracised by his understandingly distraught old mother, Jack plants the beans and a giant stalk grows up to the sky which Jack climbs in search of fame and fortune. As luck would have it there is a giant's castle up there and after several adventures, Jack steals the giant's treasure, escapes and plunges the evil monster to his death by axing the beanstalk as the giant chases down it after him. If you ask me, my sympathies are with the giant, Fee Fi Fo Fum.

So much for the intro, by the time the game has loaded all the agricultural drama is over and the beanstalk is in full bloom. There are several screens, the first being the base of the beanstalk. On each screen there is an object to be collected, without which you cannot get off the screen. On the first it is an axe. The problem facing the player is (a) discover the route up the screen - any other than the correct one will result in death, and (b) avoid the various lethal creatures flapping, slithering and jumping around.

Each screen has different graphics, which means learning each one as you go, and the overall object, of course, is to collect the money, the golden goose and escape before the giant gets you.

CRITICISM

● '*Jack and the Beanstalk* is one of the most frustrating games I have ever played. The graphics and movement are very good, so too is the sound and colour. Unfortunately the instructions don't make the point that it is impossible to get off the screen without having collected an object first. On discovering this, life isn't made any easier because of the finickiness of the program in only allowing the minutest deviation from a pre-planned route through each screen.'

● '*Read the instructions carefully - I didn't and got stuck on the first screen for almost two days. Graphics are very nicely drawn and are very colourful. The colours of some moving items have been poorly chosen, eg. a green background with yellow ink. Most of the game is frustrating due to the laws, don'ts and cannots. The sound is good but tends to drag on. This game has plenty of playability potential if you overcome the frustrating parts.'*

● '*Jack and the Beanstalk* has Currah Microspeech facility, but I found a lot of what's said is indecipherable and it slows the game down enormously. Another irritation is the between-lives routine which is prolonged and very soon drives you mad with frustration. The game would have improved

several points in my estimation if I had been able to cut it out and get on with the next life. Graphics are very colourful, well drawn and lively and the 3D effect has been used well on the second screen - almost too well, since jumping has to be calculated to the millimetre - not easy in 3D. In the end this is an excellent looking game which is almost totally spoiled by the over-cleverness of the content and which expects a lot of patience from the player.'



COMMENTS

Control keys: W/E left/right, O/K up/down, Q = jump, P = fire
Joystick: Kempston, AGF, Protek
Keyboard play: responsive
Use of colour: very good generally with only a few attribute problems
Graphics: very good
Sound: good, Microspeech slows game down
Skill levels: 1
Lives: 4
Screens: multiple
Originality: undoubtedly a very original game
General rating: perhaps too frustrating to be completely playable and addictive.

| | |
|---------------------|-----|
| Use of computer | 74% |
| Graphics | 76% |
| Playability | 60% |
| Getting started | 68% |
| Addictive qualities | 62% |
| Value for money | 68% |
| Overall | 68% |

HOW THE RATINGS WORK

| | |
|-----------|--|
| Under 30% | a waste of time |
| 31-40% | generally poor, but may appeal to some |
| 41-50% | average |
| 51-55% | reasonable if type of game enjoyed |
| 56-60% | good on most counts |
| 61-70% | generally recommended |
| 71-80% | highly recommended |
| 81-90% | knight of the British Empire |
| Above 90% | words fail... |

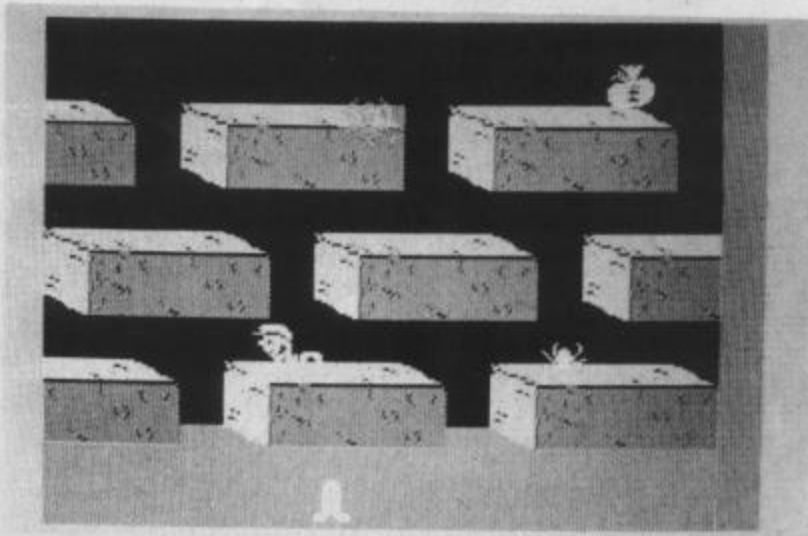

Rapscallion

Producer: **Bug-Byte**
 Memory required: **48K**
 Retail price: **£6.95**
 Language: **machine code**
 Author: **Albert Ball**

You are in low spirits – no, really you are, because your arch-enemy the dreaded and ugly Rapscallion the Rogue has seized your crown and castle and thrown you in the dungeon to rot. Aren't you feeling low?

So starts Bug-Byte's new arcade adventure. Fortunately, there are a lot of friends around to help including the fairy princess who comes to you in the dungeon and turns you into a bird so that you can escape and begin your counter-attack. From here on in you are into a large maze type game which requires nimble fingers, quick thinking and has overtones of an adventure.

Rapscallion isn't just a maze game. It certainly contains small mazes, many of them, but each of the many screens is inter-linked to form a larger maze. In each screen something different happens. There's the dining room with two gigantic faces, their mouths opening and closing, ready to catch the unwary entrant from the door of another room, there's the fiery furnace, the snake pit, the danger maze, arsenal and so on. Basically the labyrinth is split into three 'domains', the **Wilderness**, the **Magic Labyrinth** and finally the **Castle**. In the wilderness your quest is to find the key to the magic labyrinth. To do this you will need the power to see it and the magic shield to protect you from the sleepy guard. In the labyrinth you must find the pixie with magic eye which will enable you to see the three wizards who guard the castle entrance. You get into the castle when the drawbridge is lowered, but that will alert Rapscallion who knows you have escaped and is on the rampage.

Throughout the quest you make take the form of a bird or a fly. Each has its own advantages and drawbacks. Flies have little trouble with cats but are in danger of spiders and frogs, whereas birds are in trouble with cats and falling spikes but aren't too worried about frogs and spiders. Changing from one to another costs you a life. On your route you will encounter pixies who may be helpful if they're in a good mood,

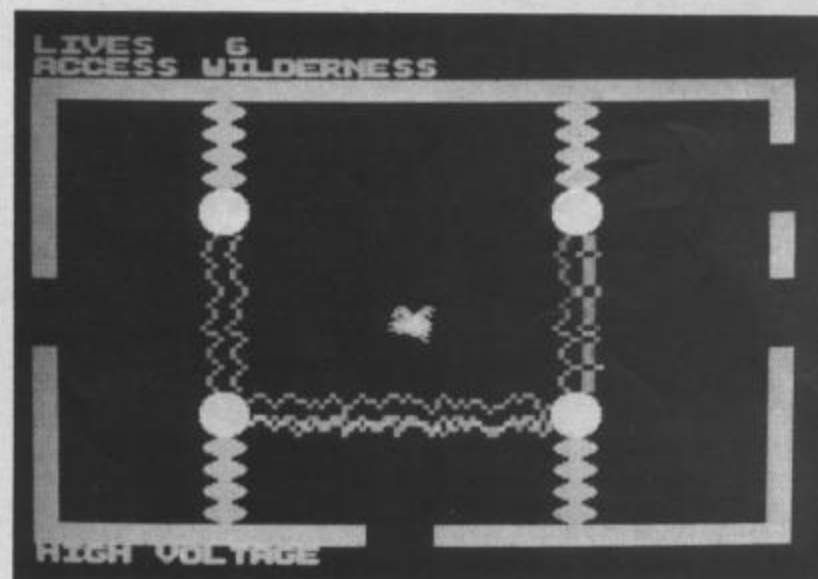
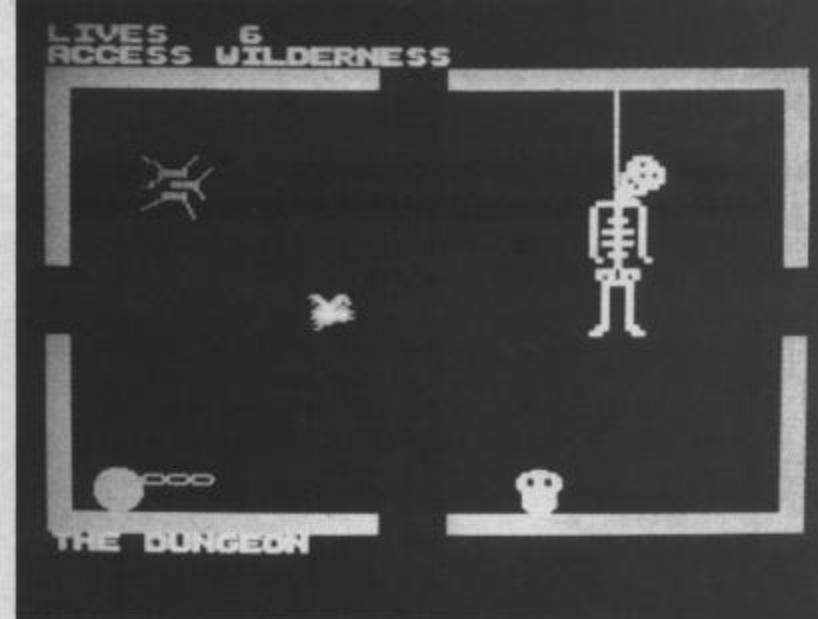

and give you valuable information. Here and there you will see gems, which when touched may also offer up information or an extra life.

Rapscallion is hard to explain adequately, because it contains many inter-linked complications, which is what adds the adventure element. But the tape contains an insert with quite comprehensive instructions as to what to expect and how to play *Rapscallion*.

CRITICISM

● 'This is an exploring/adventure game. It has many locations which are very varied, which means the game has enough changes in it to make it exciting. The graphics are of a 'teletext' type, ie. chunky. This

seems to work rather well. They call it an animated cartoon adventure. It's definitely a great animated explore but not a true adventure. I enjoyed it, think it will be a hit, and want to come back for more.'

● 'What surprised me at first with this game was the use of 'teletext' type graphics, which move in blocks! Despite this you have the advantage of moving smoothly. Several things in the game impressed me and surprised me – running into an electric force field allows you to move around the rooms at a much faster rate for a considerable time. Pixies seem to be very happy and informative and these add a nice touch to the otherwise aggressive game. I think that this game has many adventure qualities where

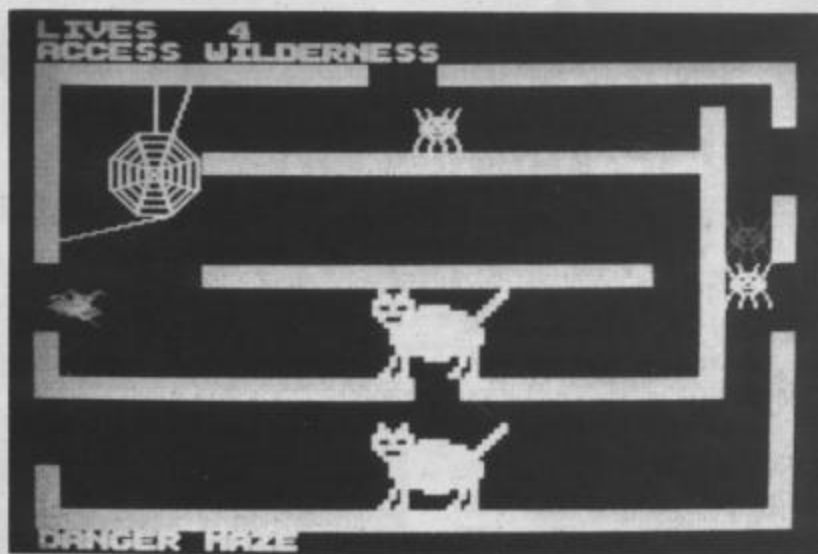

several items must be found before finding your way into the next stage. Sound and colour have been well used. A game that is enjoyable with long lasting appeal.'

● 'A neat touch occurs when you lose a life. You turn into a ghost. No you're not exactly dead, in fact you carry on wandering around the place without getting harmed by anything. On the other hand you can't do anything towards finishing the game either, so it's back to your body, press the change key, and hey presto, you're back again, bird, fly whichever. The graphics look more like the blown up drawings of Spectrum graphics you see on a designer's pad than the ones we are used to – a bit like those used on Oracle or Cefax on TV. Very clever, but all quite well animated and detailed. *Rapscallion* has a lot going for it with all the locations and does require a bit of forward thinking to make best use of your lives/changes to get through. Original and playable with quite a lot of addictivity. I would recommend it as a good game, although overall I wasn't sure whether to be impressed by the graphics or disappointed – not that they spoil the game anyway.'

COMMENTS

Control keys: Q or P/A or ENTER up/down, CAPS or SYM/SPACE or Z left/right, 1 or 0 to change
Joystick: ZX 2, Kempston, Fuller, Protek, AGF
Keyboard play: good positions, very responsive
Use of colour: very good and varied
Graphics: large, chunky, varied and smooth moving
Sound: excellent
Skill levels: 1
Lives: 6 at outset
Originality: very original
General rating: playable, addictive and very good.



| | |
|---------------------|-----|
| Use of computer | 85% |
| Graphics | 86% |
| Playability | 86% |
| Getting started | 80% |
| Addictive qualities | 87% |
| Value for money | 86% |
| Overall | 85% |

Can you break out of the factory?
We didn't!

£100 and 110
games to be
won



Factory Breakout

In last month's issue of CRASH Poppy Soft's latest game **FACTORY BREAKOUT** was rated at 90% and a CRASH Smash. In the review we said there were three different screens and showed their pictures. The thing is – we weren't quite right – **THERE'S A FOURTH SCREEN** in there somewhere.

So together with Poppy Soft, we're offering good arcade players the chance to win some more Poppy Soft games. All you need is a copy of *Factory Breakout* (in the shops now, or available direct from Poppy Soft or CRASH Mail Order Department) and a set of nimble fingers and good eyes!

The question is very simple (getting the right answer may be a bit harder!):

Identify in detail what happens on the fourth screen of Factory Breakout.

The first hundred correct entries out of the bag will each receive a free game (not *Factory Breakout* of course) from Poppy Soft. **The first ten** correct entries drawn will receive, in addition, an advance copy of Poppy Soft's next game (due around December). **And the first drawn from the bag will also receive £100 on top!**

The next Poppy Soft game is provisionally titled *Wizard's Lair*, although this may be altered before its release, and it is a 3D arcade adventure game set in 250 locations.

The **FACTORY BREAKOUT COMPETITION** will run for two months and there will be a reminder in next month's issue. So the closing date for this competition is **September 27.**

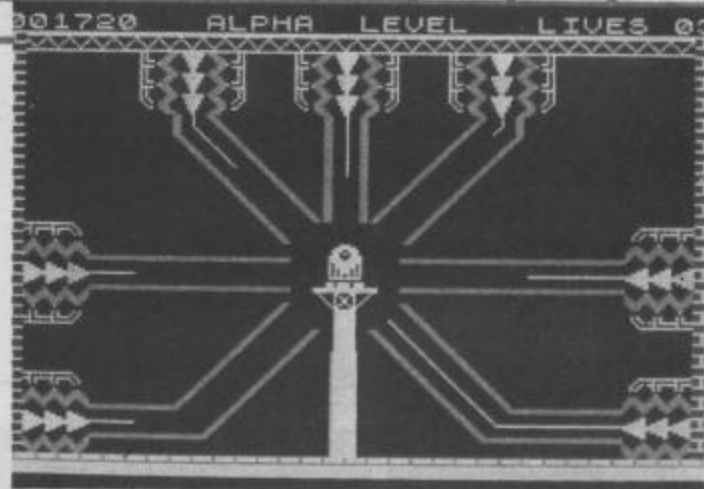

1

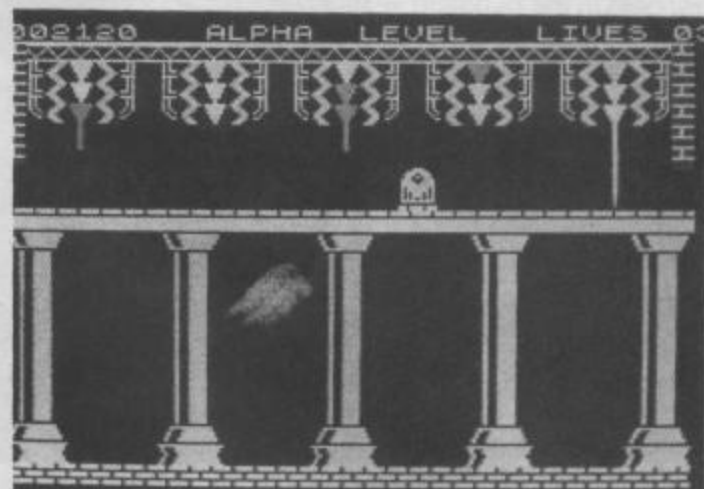

2

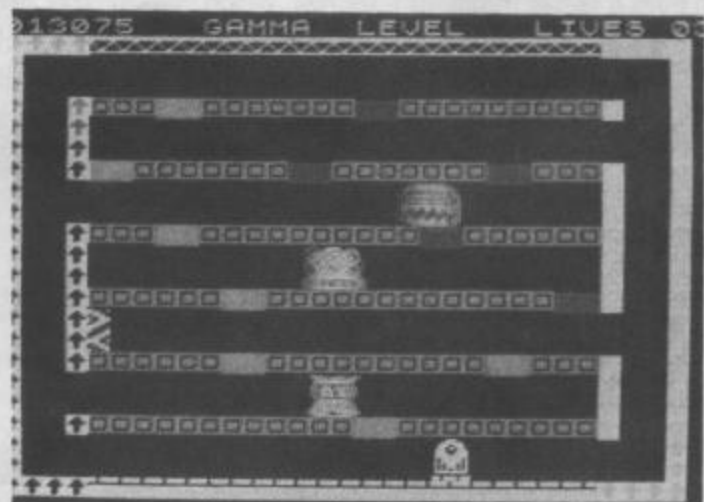

3



4

Answers on a postcard (or outside of a sealed envelope) please, sent to **FACTORY BREAKOUT COMPETITION, CRASH MAGAZINE, PO BOX 10, LUDLOW, SHROPSHIRE SY8 1DB.**



T-shirts & Binders Offer

Great T-shirts in high-quality 100% cotton with double stitching on neck and shoulder seams for lasting wear. Three sizes, in black with a brilliant CRASH design in three colours.

£4.50 incl p&p

Fab Sweatshirts are long-sleeved, heavy quality and fleecy lined with double stitching on neck and shoulder seams for durability. Colourfast, machine washable navy blue with CRASH design in three colours. Three sizes.

£8.95 incl p&p

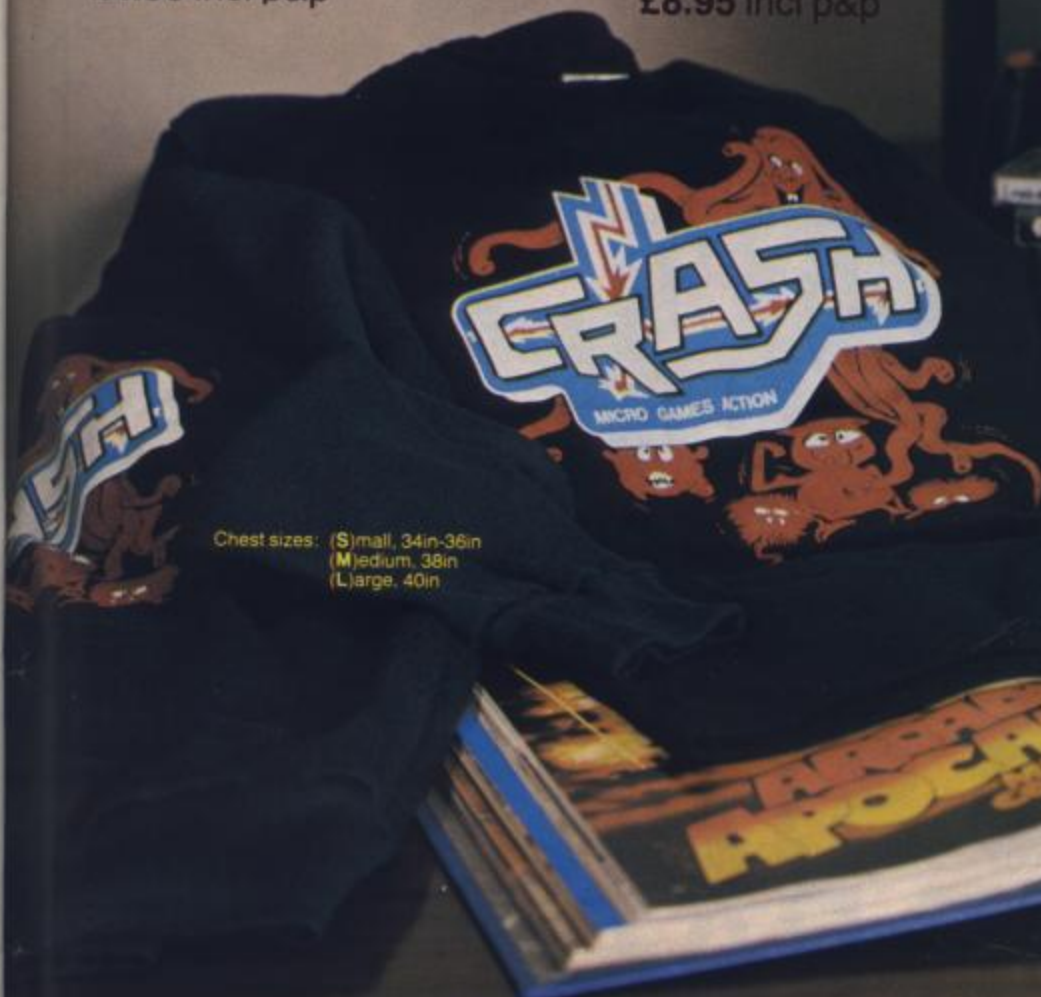

Chest sizes: (S) small, 34in-36in
(M) medium, 38in
(L) large, 40in



Build yourself the most comprehensive manual on Spectrum software ever seen! Save your issues of CRASH month by month, and turn them into the hard cover with the fattening soft centre!

Our fat binder doesn't just look impressive with its silver blocked CRASH logo and dark blue finish, it's also strong enough to hold a year's supply of CRASH away from your friends! And it's only £4.50 including postage and VAT!

FREE IN-DEPTH INDEX!

As Lloyd Mangram mentioned in his letters page, he's been told to get it together (we've generously provided him with a second tiny desk) and organise an Index for the 12 issues your binder will hold. The index is **absolutely FREE** to anyone who orders the binder and will be sent automatically in January.

So make sure you turn your issues into the **CRASH Spectrum Software Encyclopaedia!**

Be a Superior Alien with your very own CRASH T-shirt and sweatshirt!

Please send meCRASH T-shirts Name:.....
@ £4.50 S M L Address:.....

.....Sweatshirt @ £8.95 S M L

Please send.....CRASH Binder(s) at £4.50 I enclose Cheque/PO payable to CRASH MICRO £.....
(overseas orders please add 40p). Please allow 28 days for delivery

CRASH MICRO, Freepost, Ludlow, Shropshire SY8 1BR

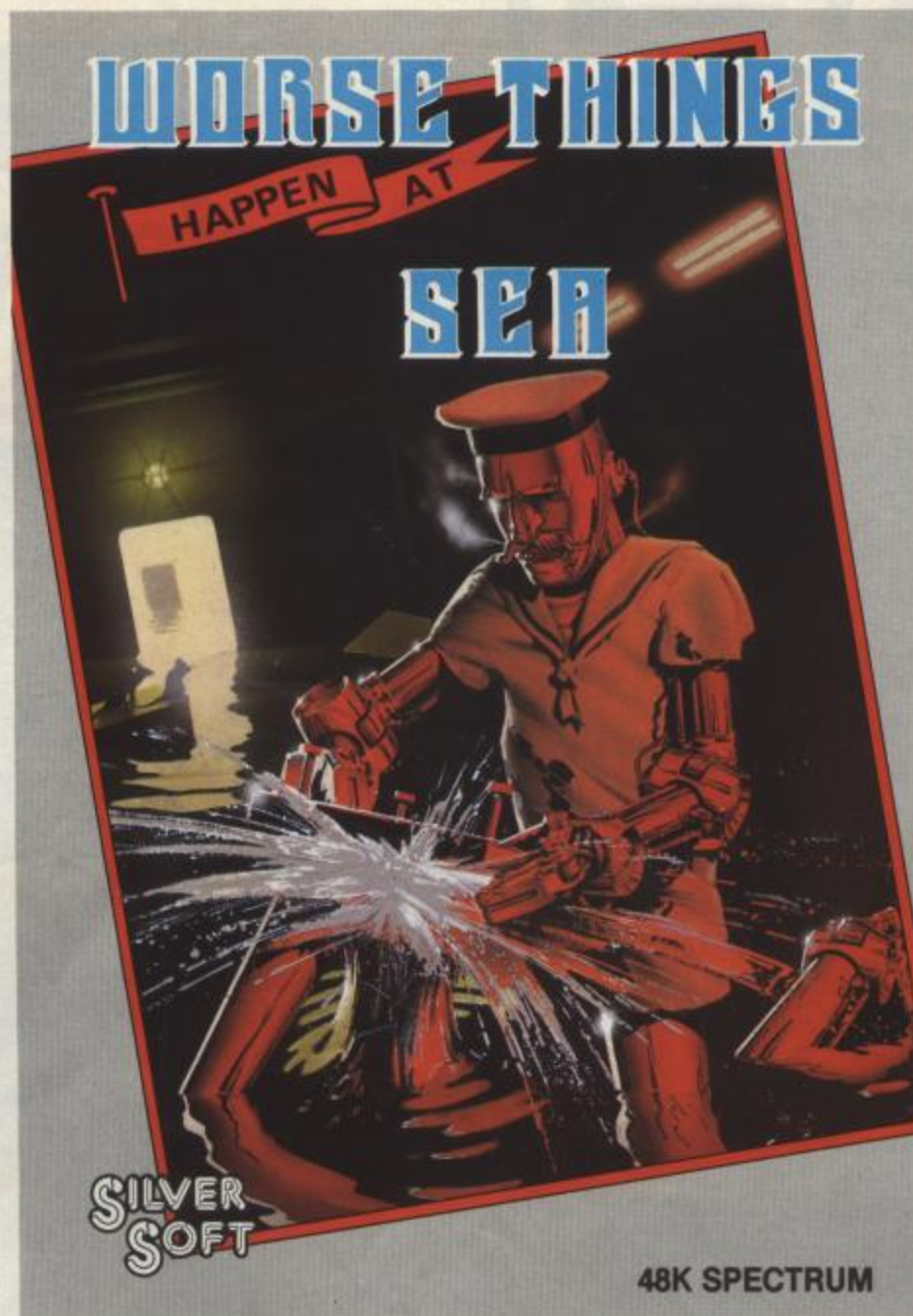

FOR ADDED REALISM PLAY THIS STANDING IN THE BATH

You'll probably stay there till
someone pulls the plug!

Controlling this nautical nightmare is
stormy stuff, especially with only first
officer C-Droid to help you. Is the old
sailor worth his salt? Or is he just a
Jonah?

Dive down to your dealer now for
the answer — but be warned — this
game will send you overboard!

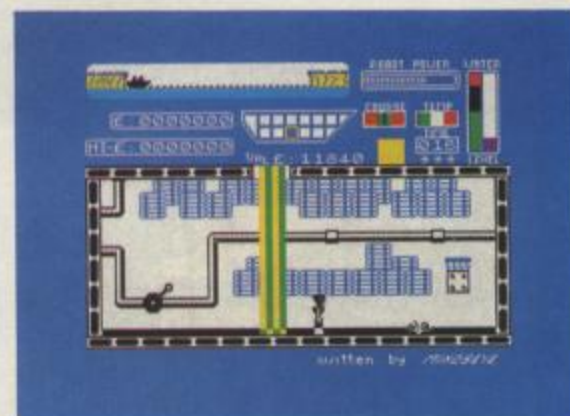

**SILVER
SOFT**



For the 48K ZX Spectrum
**BRINGS YOU INTO
 THE ACTION WITH**



FACTORY BREAKOUT – For the 48K ZX Spectrum. Help Zirky escape from the factory that's gone haywire. Three screens of thrilling arcade action. 100% machine code, super smooth animated graphics and amazing sound.

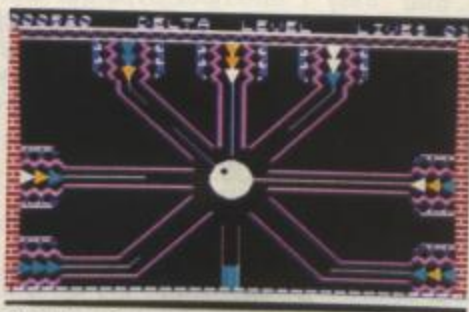

Zap the micron rays to hatch out of the egg capsule.

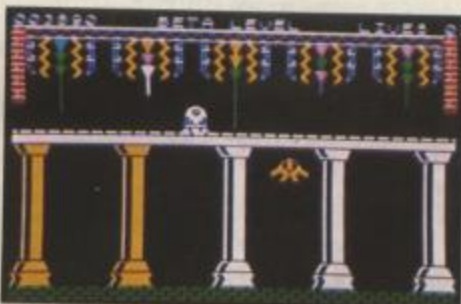

Dash across the conveyor belts on the reject line – don't let the killer canary catch you!

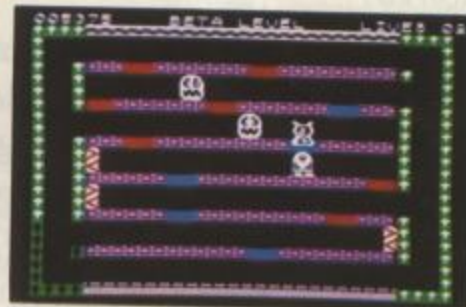

Battle against the many weird monsters in the lift room.



LASER SNAKER
 for the 48K ZX Spectrum
 Gobble the eggs in the plantation. Zap the aggranoids and vicious viproids to fight your way to the centre of the four mazes.

HANGMAN and BOUNCE PANIC
 for the 48K ZX Spectrum
 Two great games for the price of one! Graphical hangman is excellent for young children plus Bounce Panic – a great arcade game.



£5.50 each including VAT and Postage

**SPECIAL OFFER ANY 2 FOR £7.95
 OR ALL 3 FOR ONLY £9.95!**

AVAILABLE AT LEADING SOFTWARE STORES
 DISTRIBUTED BY LIGHTNING RECORDS

POPPY SOFT The Close, Common Road,
 Headley, Newbury, Berkshire.

**POST NOW TO: POPPY SOFT, The Close, Common Road,
 Headley, Newbury, Berkshire.**

Please send me

- FACTORY BREAKOUT** **LASER SNAKER**
 HANGMAN and BOUNCE PANIC @ £5.50 each

I enclose a cheque/P.O. payable to: POPPY SOFT

for £..... Signature

or debit my Access No.

Name

Address

.....

..... Post Code.....

Crash back

As summer poises, ready for the onslaught of fab new games around Christmas, CRASH takes a look back at some of the major games we have reviewed in the past to see if they (and the reviews) stand the test of time. MATTHEW UFFINDELL and LLOYD MANGRAM take keyboard and reputation in hand...

Games this month:
Bugaboo (The Flea) **Push Off**
3D Ant Attack **Maziacs**
Transversion **Lunar Jetman**
Splat!

All games reviewed in
 CRASH issue 1 (February)

Bugaboo (Quicksilva)

Of Both *Bugaboo* and *3D Ant Attack*, we predicted 'great things' and went out on a limb after a few glasses of Quicksilva's champagne to say that both games were in the top class. Evidently sales and popularity in the CRASH HOTLINE have borne this out, less perhaps in the case of *Bugaboo*.

No one has ever bettered the loading screen sequence on *Bugaboo*, with its totally cinematic titles. It's not necessarily a point in the game's favour, but it surely does get you in the right frame of mind to play it.

As the months go by and software improves, past hits seem to disappear out of memory, *Bugaboo* is still one of my favourite games on the market. The graphics are among the best, and I rate it around the *Jet Set Willy*, *Atic Atac* class. After seeing so much great software over the last several months, this game still has a fantastic addictive quality and is still one of the best games produced for the Spectrum.

MU

The thing that still strikes about *Bugaboo* is the unusual and attractive screen layout. But it's not only good to look at, it's also cleverly designed to make life difficult. Everything about the game, as far as I'm concerned still stands up well to later software. Any game loses much of its addictivity once conquered and I know a number of letter

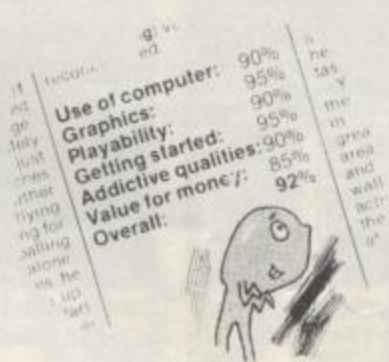

writers have said that they don't want to play it again. But to me, it seems that *Bugaboo* always demands skill in timing and forward planning to beat it.

LM

(Matthew) I wouldn't quarrel with any of the ratings in the original review, and if anyone asks me what should be their first game for the Spectrum I tell them, *Bugaboo*.

(Lloyd) I wouldn't argue with the graphics rating or playability, perhaps the addictive rating was a trifle high - it has something to do with the dragon! He's a nuisance!



Still one of the best, *Bugaboo* casually awaits the end...

3D Ant Attack (Quicksilva)

Ant Attack has remained high in the HOTLINE charts since we started them, proof of the game's popularity with players.

There have been many failing attempts over the last several months to get fab 3D effect graphics like *Ant Attack* - it's still one of the leading 3D games. Playing it now shows that much more colour could have been added. Content and addictive qualities have dropped dramatically. Also a major point on the graphics is that if 100% (which it received in the original review) is given then nothing can beat it. I would now rate them at 74%, the reason being that they are unimaginative and uncolourful. Not such a good game itself but still worth buying just to see the 3D effect.

MU



Oddly, *Ant Attack* came out with a much lower overall rating than *Bugaboo* (85%) but of course scored on the graphics, still to be beaten in their particular 3D effect. I think we were all a bit overcome by them at first and failed to note that the game itself isn't so great. With the graphics, it isn't only the city which works so well, but the animation of you, your rescuee and the ants is excellent. Incidentally, although it appears to be of no use, there is an ammo dump out

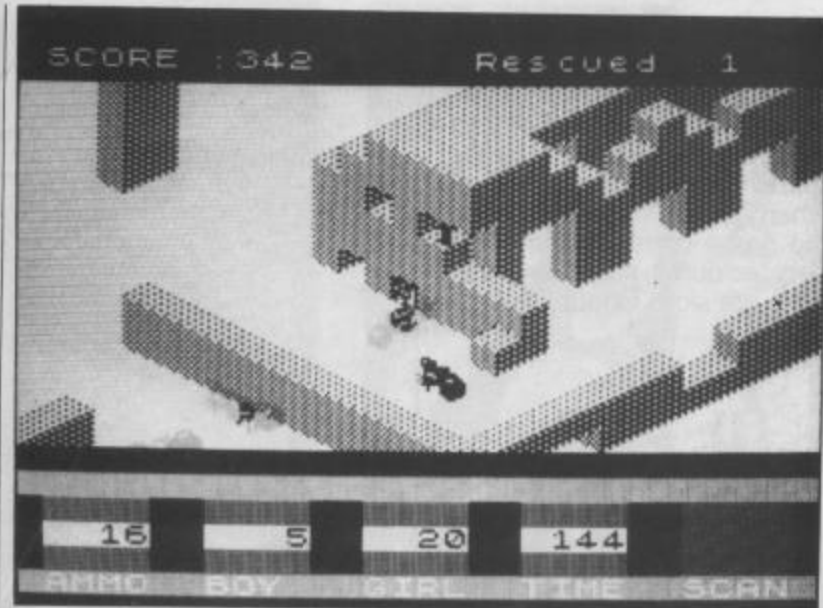

in the desert, but it seems to be nothing more than a visual gag put in for those players who inevitably were going to go off exploring.

LM

(Matthew) I think I would want to knock about 5% off the playabil-

ity rating and some 10% off the addictive qualities given originally as the only real objective is to continually rescue your girl/boyfriend and they are always in the same locations each game.

(Lloyd) I agree.

Transversion (Ocean)

Transversion was a surprise rave in the first issue of CRASH and the first of a series of Ocean hits by Chris Urquhart with his friend, Nick Pierpoint. In the original review we said, 'A game that will not be tired of easily.'

Transversion is still the best, most playable and slightly less addictive game that it ever was - nobody's improved on it - and since there have been quite a few attempts, it looks as though no one can! The graphics are small by today's standards but perfectly adequate with good

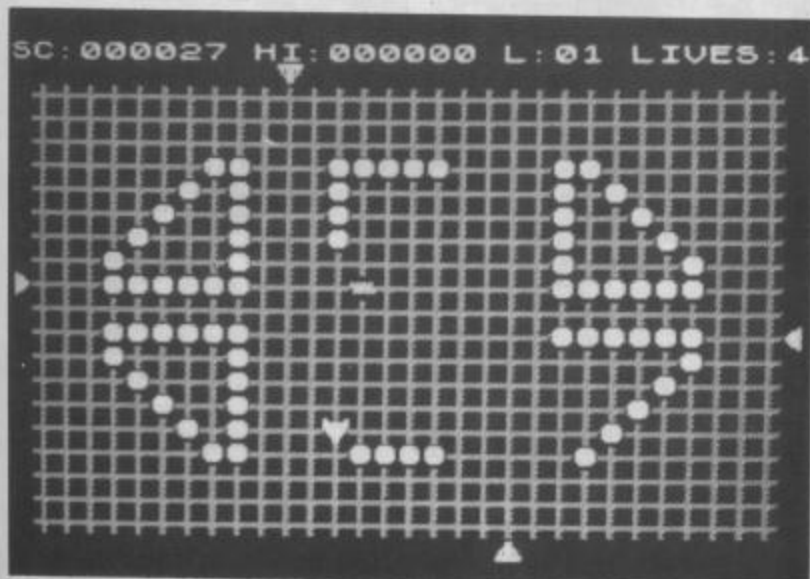

It hasn't been out-transversed yet.

colour and sound. If you want a grid game, this one is still the best.

MU

There have been faster and more complex versions of this game but I don't think any of them has bettered *Transversion*. The success of the game then was its simplicity, and it still shines out. It's one of those mind-boggling games at which you will eventually fail because your reflexes will not stand up to it. That makes it addictive. I really enjoyed getting this one out again.

(Matthew) Use of computer (95%) looks very over the top by our reviewing standards today. The keys are good and responsive, but the joystick options aren't so extensive. And I think if I was reviewing it now, I would drop the addictive qualities to around 70%, but it's still great value for money.

(Lloyd) I don't think I would quibble with the review much, although the ratings for use of computer and addictivity do seem rather high but I would certainly keep the playability figure intact (83%).

Crashback

| | |
|------------------------------------|-----|
| General rating: highly recommended | |
| Use of computer: | 95% |
| Graphics: | 70% |
| Playability: | 74% |
| Getting started: | 85% |
| Addictive qualities: | 75% |
| Value for money: | 90% |
| Overall: | 81% |

scrolling maze quite like this, so it does have a skill factor all of its own. The time has gone when a character like Zippy is not animated to some extent although most graphics (for this type of game) cannot be altered as playing the game becomes too complex. The game is still very playable in itself although I can only play it in short doses. I thought that the majority of its charm had worn off due to more attractive and playable games.

MU

Perhaps the fact that the computer yelled 'Yippee!' at me when I completed a level had a lot to do with liking *Splat!*. It was almost unique at the time. *Splat!*'s originality hasn't really been challenged in the sense that the screen edge is your worst enemy in this game and the scrolling maze idea was certainly novel and gave the game its playability.

LM

(Matthew) I wouldn't give use of computer 95% - not with cursor keys for control, and I think the value for money (90%) was an over-rating.

(Lloyd) I always thought *Splat!*

Splat! (Incentive)

As a hero figure, Zippy is lacking in charisma by today's heroic figures, people like Willy, Wally and Ziggy, but *Splat!* got a good review because of the game itself, not for the sprite animation. We said, 'This is a game with growing appeal and a thoroughly mean, ornery streak which guarantees its addictivity.' Were we right?

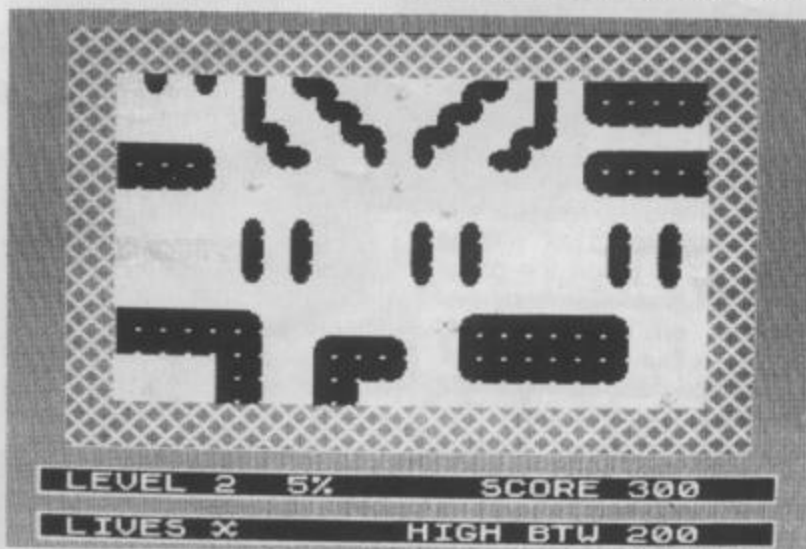

I still find *Splat!* an unmasterable game due to the fact that no set route can be taken. Most maze games do have a set route, but with *Splat!* you never know which way the maze is going to scroll, or what all of it looks like. Oddly enough, nobody else has brought out a

was fun, so I wouldn't change my mind now, having just re-played it, but perhaps the ratings were over-generous in some respects like use of computer, but I might be tempted to bump the addictive rating (75%) up a little bit.

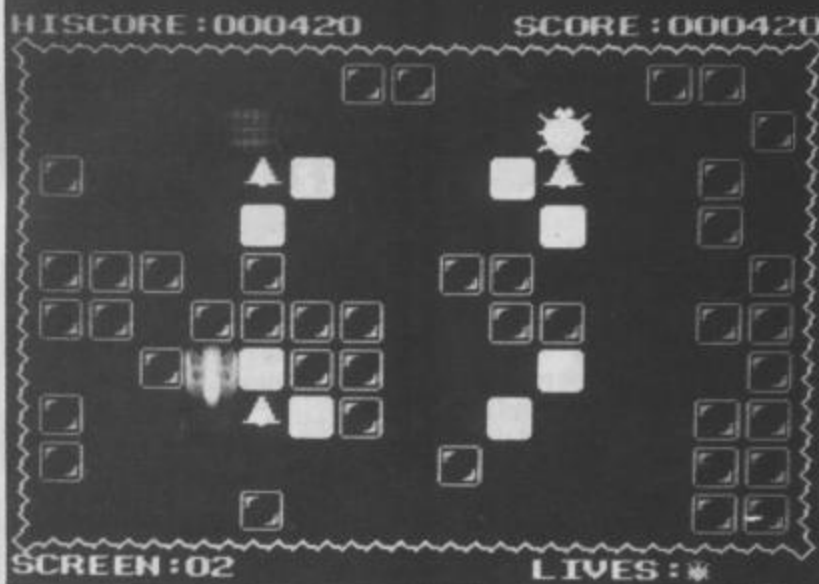

Fresh, attractive graphics make Push Off a still playable game.

Push Off (Software Projects)

Push Off was among the first releases from the newly formed Software Projects, formed by Alan Manton after leaving Imagine, and the second Pengo type game from the Spectrum.

With many of these types of game on the market now, Push Off has stood the test of time and I still think that it's highly playable. Content in Pengo games is never very good, this is one of the better versions. The addictive qualities have worn off as there are many more content-high games available (in a general sense). The graphics are good but with none of the latest great animation.

MU

| | |
|---------------------|-----|
| Use of computer | 78% |
| Graphics | 89% |
| Playability | 90% |
| Getting started | 80% |
| Addictive qualities | 85% |
| Value for money | 87% |
| Overall | 85% |

Pengo games were never my strength, so Push Off was always a favourite because of its little frills. The bells to be rung (making the bugs dizzy so you can run them over) seemed a better answer than the electrified walls, and the fact that you can create blocks as well as destroy them made the game easier to control. Perhaps that indicates an arcade playing weakness, but I liked Push Off. Its graphics stand up well, bright and exceptionally smooth. The control keys were a bit awkward and, of course, they still are!

LM

(Matthew) I would drop the playability (90%) and the addictive qualities (85%) down to about 70% now, otherwise I would think the review still stands.

(Lloyd) I would drop use of computer (78%) and playability if reviewing it today. The addictive qualities are a little over the top as well.

Maziacs (DK Tronics)

Maziacs was one of those vast mazes which began to be popular about this time (excepting the 3D types). CRASH said it had 'plenty of appeal with lots to do and good animation. Overall 82%.

This large maze/adventure game still has plenty of appealing qualities although perhaps the action seems a little on the

slow side - fights become long and boring instead of exciting. Moving graphics are detailed but the maze is very uninteresting. This does seem to detract from the game although it didn't when I saw it first. In retrospect the game doesn't seem to be very colourful now. Key reactions are slow. Unaddictive and boring.

MU

| | |
|---------------------|-----|
| Use of computer | 80% |
| Graphics | 78% |
| Playability | 84% |
| Getting started | 80% |
| Addictive qualities | 88% |
| Value for money | 82% |
| Overall | 82% |

Maziacs stands up now because with the exception of Chuckman (I'm sure Chuckman borrowed the graphics) there hasn't been another game quite like Maziacs. Everything is large and bright, if somewhat unimaginatively coloured, and the animation we raved about then, still looks amusing and good today. For its originality and playability, I would still stick

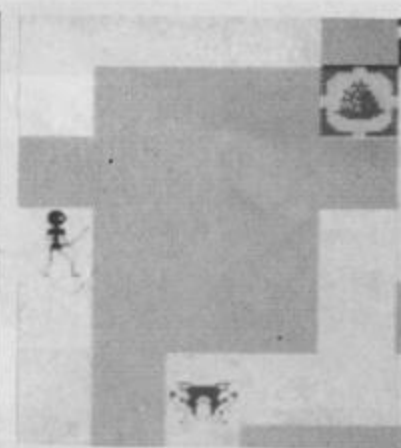

with the review even if a few of the ratings may have paled a little in comparison with later games.

LM

(Matthew) I would agree with the use of computer rating (80%) because the keys are not very responsive. I would also drop playability (84%) and addictive qualities (88%) - say down to the higher seventies.

(Lloyd) That seems fair - I know the use of computer was rated high because this was among the first games to have user-definable keys, but it's true that responsiveness to input has been improved a lot since.

Lunar Jetman (Ultimate)

This game was eagerly awaited after the thrills of Ultimate's first game Jetpac. Would it be an improvement? Everyone thought so because Ultimate had insisted on being 16K before - this was the first 48K game.

| | |
|---------------------|------|
| Use of computer | 90% |
| Graphics | 99% |
| Playability | 95% |
| Getting started | 90% |
| Addictive qualities | 95% |
| Value for money | 100% |
| Overall | 95% |

When Atic Atac appeared about a month after Jetman's release, Jetman seems to have been forgotten. I don't know why - it still greatly appeals to me; but has lost some of its addictive qualities, which is odd considering it still has fantastic playability. It's the same frantic, impossible game that it ever was and is worth buying if you love fast, detailed shoot em up graphics.

MU

My first reaction initially to Jetman was all the keys - what a handful! Our review then said, 'Marvellous seems an inadequate word.' A statement I would

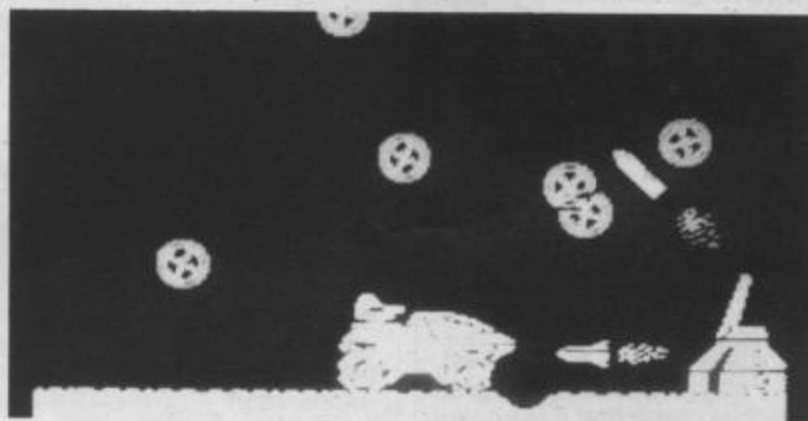

still agree with now. Ultimate had managed in a short space of time and with very few games to establish themselves as a leading software house with 'state of the art' programs. Jetman was certainly ace. Today it is still playable, as witness its popularity among hi-score freaks (who did not forget it when Atic Atac came out) and because of the massive nature of the game, remains as addictive as ever. Incidentally, recent rumours that trailers have been spotted in the game are purely

imaginative, as Ultimate could not fit the trailer in the width of the screen.

LM

(Matthew) On use of computer, I would still argue that the many keys make it hard to play, but that responsiveness makes up for it. In general I would say that all the ratings were just a little bit over the top.

(Lloyd) Well I'm afraid I wouldn't change a thing, not even that extravagant 100% for money value.

It would be rather sad as a statement on the software business if games that looked absolutely wonderful a year ago, didn't look a little less so now. On the other hand something which is described as 'classical' is so because it stands the test of time. The real point, perhaps, is how many allowances you feel you have to make for an older game in order to allow it to remain a 'classic'. Of the seven looked at here, we feel that Bugaboo (The Flea) and Lunar Jetman have stood the test of time best of all.

PROFILE ON A KEYWINES!

We look at Advanced Memory Systems LO PROFILE keyboard.

It is surprising to see that over 1 year after the introduction of the first add-on keyboard for the Spectrum, a flood of new keyboards are suddenly appearing on the market. Although an expensive extra, the keyboards enable many owners to use their Spectrum for business applications. Certainly the major deficiency of the Spectrum is its moving keyboard, which is quite an improvement over the ZX81 but still miles away from the full travel typewriter style keyboard of its competitors. Added to this the multi-role, single stroke per function keys have been a constant source of argument as to whether they are a merit of deficiency. The aftermarket keyboard should correct all these deficiencies and upgrade the Spectrum to a more serious home computer.

THE HARDWARE

At first glance the size of the keyboard enclosure suggests a lot of hidden extras, but it soon becomes apparent that the only reason for the Cadillac proportions is the restricted choice of low cost standard keyboard enclosures on the market. The enclosure size tends to dwarf the actual key cluster. The white and grey keytops are certainly the best seen on any Spectrum keyboard with excellent legends using the original colours for extended, symbol and caps shift mode functions. The key cluster has a moulded shape with the front row tilted and slightly projected which allows easier reading of the front row extended mode functions such as Beep, Ink, Paper etc.

The key action usually generates a lot of controversy amongst users, but from my own personal experience I found the action fairly light and giving a good feedback,

although just a little bit soggy. Probably a very fast touch typist would find this effect would slow down his or her typing speed, but I should think for the average user the action is perfectly alright. The slightly soggy feel is in fact the only give away clue, that the owner hasn't escaped the membrane type keyswitch however refined it may be. The switching action is generated by the collapse of a rubber membrane cup with a graphite contact which bridges two interleaved tracks on the printed circuit board. This gives, in combination with the keytop plunger, a nicely balanced and smooth travel. It may be worth pointing out that nearly all low cost home computers feature similar membrane type keyswitch mechanisms (including the QL), as this allows a tremendous cost saving compared to the orthodox keyswitches.

Another interesting feature

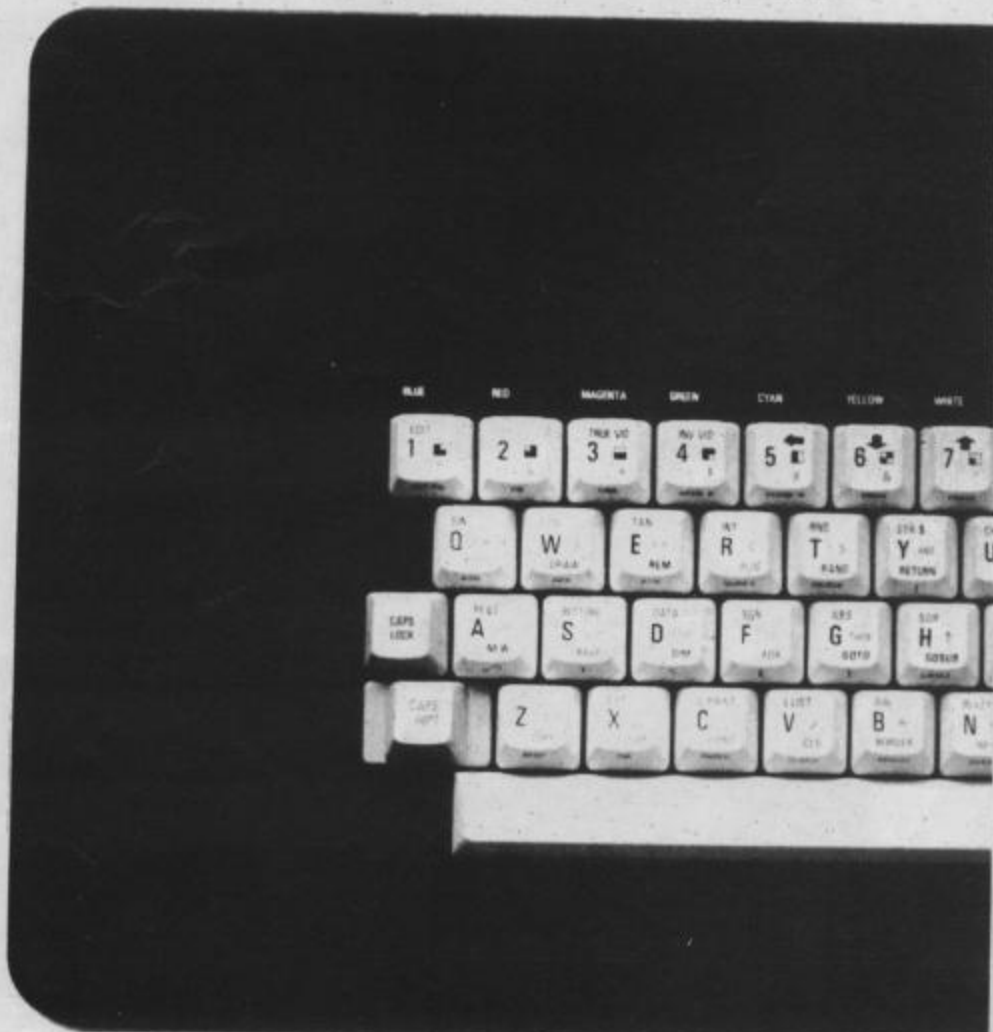

not apparent to the user is the technology of the printed circuit board, which is not through hole plated as usual, but boasts similar techniques as used with thick film hybrids with silk-screened conductive ink tracks running over the copper tracks of the printed circuit board.

KEY LAYOUT

The keyboard features a full length spacebar, a fake caps lock (cap shift and caps lock have to be pressed combined) and a separate numeric keypad with a further cap shift key for the oddly positioned cursor keys in the numeric pad. The layout proves to be a bit of a disappointment as the only benefits are the full-length spacebar and the numeric keypad. It would have been nice to include an extension mode key, stop and comma keys and a cursor cluster all accessible with a single stroke. Nevertheless the layout is practicable and because it is equivalent to the original, the Spectrum owner will instantly feel at home with it.

INSTALLATION

The installation represents no problems. The Spectrum printed circuit board is fixed via 4 screws, nuts, nylon washers and counternuts onto the plastic vacuum-formed base of the keyboard, which is very flimsy



and bows and twists in all directions until fixed to the solid enclosure main body. The ribbon cables of the keyboard plug into the usual sockets of the **pcb** and that concludes the easy set-up procedure. There is no provision to fit any other add-on inside the case, but the ZX Interface 1 may be connected from the outside and will come to rest underneath the keyboard case giving it an improved tilt which provides a better typing position. An extension cable is however required for connecting up the microdrive unit to the Interface 1 due to the extended dimensions of the keyboard enclosure.

CONCLUSION

The **LO PROFILE** provides the Spectrum with a good low

profile, full travel keyboard. The keys have a very legible annotation and provide a good feel when typing. It fails however to provide extra benefits such as single stroke extended mode, punctuation and sensible cursor keys. Here the **Fuller, Transform and Saga 2 Crusader** keyboards definitely score points.

Add-ons may be connected as usual to the extension bus, but no provision is made to fit them inside the keyboard case such as with the **DK'Tronics** unit, where the ZX Interface 1 and power supply all fit inside the cavernous case. But where the **DK'Tronics** keyboard is enormously bulky and unhandy to use because of its very high profile, the Advance Memory Products **LO PROFILE** is exactly what it says, low profile,

even if somewhat expensive in respect of required desk top surface.

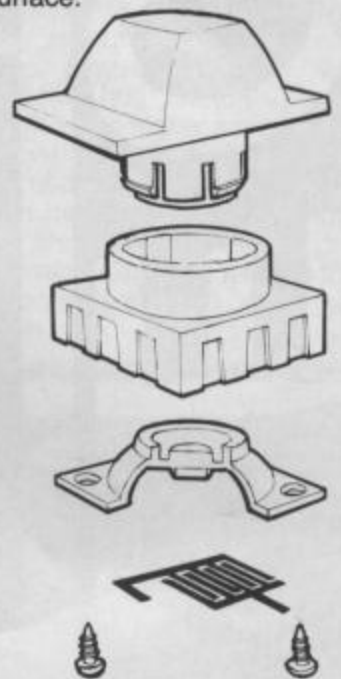

PROFILE ON A KEY WITNESS

FRANCO FREY

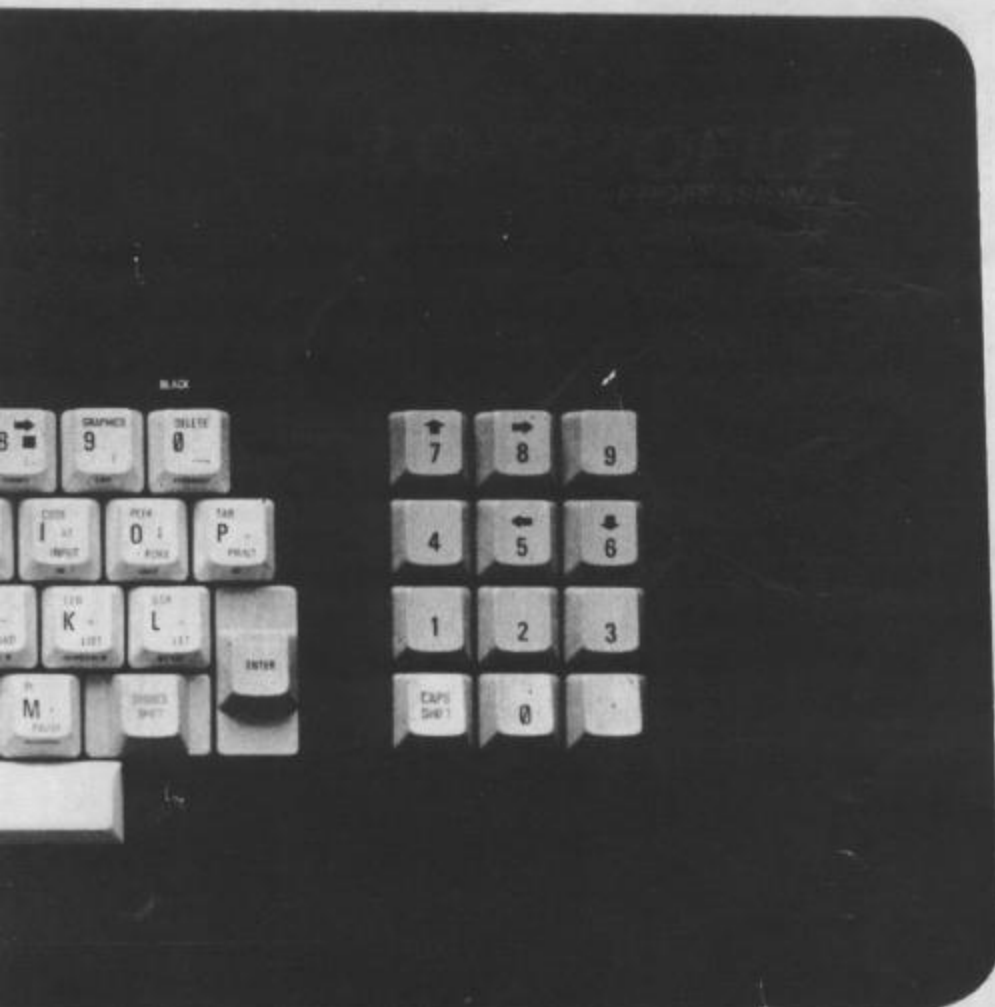

UPDATE:

Marooned on an unknown world, the passengers of the wrecked liner "Arcadia" are about to perish in a ritual religious sacrifice. Since their capture they have seen nothing of Cross, the man pledged to saving them, but as the ceremony approaches its hideous climax...

THE TERMINAL MAN



SPEAK, VILGARRE! CALL OFF THIS BARBARIC RITUAL!

END THIS OUTRAGE, MY LORD!

— STRIKE DOWN THE BLASPHEMER — GIVE THE ORDER TO CONTINUE!!!

THE HARSH WARLORD SEEMED MORE INTRIGUED THAN OUTRAGED!!!

NO! DELAY THE CEREMONY—

— I WANT TO SEE THIS STRANGER DEAL WITH THE ALTAR GUARDS!!!

CROSS' COMPANIONS, JIN KIMAS AND MANDRELL EASED THEMSELVES FROM THE CROWD!!!

COME ON, THEY'LL SLAUGHTER HIM! WE MUST BACK HIM UP!



BUT, AS THE BLADE SCYTHED TOWARDS HIM, CROSS REACHED OUT - AND!!!



CROSS' METABOLISM WAS A STRANGE MIXTURE OF HUMAN, VIRUS AND COMPUTER - MANGLED INTO ONE AT THE CRASH -

- HIS BIZARRE HYBRID CELLS COULD REPAIR DAMAGED TISSUE MANY TIMES FASTER THAN NORMAL -

- BY THE TIME HE REACHED THE SWORD, THERE WAS LITTLE TRACE OF THE TERRIBLE WOUND!



STORY BY KELVIN GOSNELL ©

DRAWN BY OLIVER FREY ©



YOU HAVE SOMETHING THAT BELONGS TO ME, VILGARRE—

I WANT THESE PEOPLE BACK.

—AND YOU HAVE SOMETHING THAT I WANT, I THINK IT IS TIME TO BARGAIN !!!

CANCEL THIS CEREMONY AND SPARE THE PRISONERS—FOR NOW— I MUST TALK WITH CROSS !!!

BUT MY LORD! YOU CANNOT STOP THE CEREMONY! THE WRATH OF THE GODS WILL BE VISITED UPON US AND —

THE WRATH OF VILGARRE IS MUCH CLOSER THAN THE WRATH OF THE GODS, PRIEST— IT ALSO HURTS A GREAT DEAL MORE— THE CEREMONY IS CANCELLED— SEE TO IT!

SOON, ON THE BALCONY OF VILGARRE'S PALACE...

SO YOU SAY THAT THESE GREAT GLOBES IN THE SKY ARE OTHER WORLDS LIKE THIS ONE— AND I COULD TRAVEL TO THEM !!!

YES— IN A SPECIAL SHIP, WE CAME IN ONE— BUT IT IS DESTROYED,

ARE THERE ANY MORE SOURCES OF WHAT YOU CALL 'RELICS' AS WELL AS THE SITE TO THE SOUTH?

YES, AWAY TO THE NORTH, BUT IT IS IN THE 'BURNING LAND'— FEW MEN RETURN ALIVE— ONLY THOSE WITH THE BURNING FEVER SURVIVE— IT IS A LIVING DEATH!

YOU WILL FIND ME ANOTHER SHIP— YOU WILL FIND IT WITHIN 30 DAYS OR YOUR PASSENGERS START TO DIE!

IMPOSSIBLE! WE FOUND SOME OLD SHIPS, BUT THEY CANNOT FLY!

THEN THAT IS WHERE WE START OUR SEARCH !!!

BUT, CROSS— EVEN IF WE SURVIVE— WHAT OF THE OTHERS— HOW CAN WE KNOW HE WILL NOT KILL THEM THE MOMENT WE LEAVE?



-AND WIPE HIS CITY INTO NOTHINGNESS -

BECAUSE HE KNOWS THAT IF HE HARMS ANY OF THEM I WILL RETURN -

AND SO, AS CROSS LED JIN AND MANDRELL INTO THE WILDERNESS ///

VILGARRE ENTERED A DARK FORBIDDEN DUNGEON IN THE BLACK HEART OF HIS PALACE ///

WAKE HIM!

BUT MY LORD - IT IS ONLY THREE YEARS SINCE LAST TIME!

- HE WILL BE ANGRY!

WAKE HIM - OR I'LL DO IT MYSELF AND FEED YOU TO HIM!

Y-YES, MY LORD,

KARRIAN - KARRIAN CAN YOU HEAR ME? IT IS VILGARRE! I NEED YOU, KARRIAN -

WHY!? WHY DO YOU WAKE ME, YOU MORTAL DOG? WHY BRING ME BACK TO YOUR HELL!?

IT IS OUR BARGAIN, KARRIAN! - THERE IS ONE WHO MUST BE FOLLOWED - AND THEN KILLED WHEN HE FINDS SOMETHING -

- THEN YOU CAN REST AGAIN - FOR YEARS ///

- THE BURNING LAND ///

WHERE MUST I GO?

IT IS GOOD - I WILL GO, THERE IS MUCH DEATH THERE -

- I WILL BRING MORE!

Next: The Burning Land...

ARCADE

GAMES THAT FIGHT BACK!

NEW RELEASE

THE PRIZE



Selected titles available from:
 W H Smith, Boots, Menzies,
 and All Good Computer Stores

UP TO £5000 FIRST PRIZE



A Fast-furious racing in this Arcade game for the Spectrum. 'Pontoon' on side B free!



B Funny goes-on deep in a mine. Can you escape the evil in its depths? "Original and fun . . . dexterity needed . . . strategy is also involved" — Games Computing.



C Defuse a bomb hidden on the complex planet, Lattica, before it blows!! "... action packed game... addictive" — Sinclair user.



D The mobs out to get ya' in this no-holds-barred 25 screen, action-packed game. "Tricky and highly entertaining" — Personal Computing News.



E 50 different screens of mayhem. "A fun game for all ages . . . which I thoroughly enjoyed." — Home Computing Weekly.

F The Prize Your mission to discover the innermost chamber of Midas in a huge planetary maze. If successful you could be in with a chance of winning up to £5000! Only the strongest will survive the devious traps set by the guardians, but just imagine what you could do with the prize. . . .

Cassette carries a special £2 discount voucher off your next purchase!

Dealers, please contact us for very special discounts on our games. Phone Orpington 35639.

Programmers. We are looking for high quality m/c games for the Spectrum and Commodore 64 home computers, send them in for evaluation. You have nothing to lose!

All games are for the ZX Spectrum 48K and cost just £5.50 each inc. p.p. VAT etc.

Arcade Software Ltd, Technology House,
 32 Chislehurst Road, Orpington, Kent BR6 0DG
 Tel: Orpington 35639

A I enclose a cheque for £ _____ or
 B debit my Barclaycard/Access Account★
 C Name _____
 D Address _____
 E _____
 F _____ SU/8/84
 _____★

NOT JUST A PRETTY ^{Inter}FACE!

This superb new interface is one of our very latest developments for your Spectrum. Offering even more features, as it's programmable from the keyboard or with the cassette supplied you can now use it with any software. Programmable for up to 17 directional movements i.e. diagonal and fire.

Features include:

- 17 directional movements
- Keyboard remains fully functional
- Works with quick shot to rapid fire actions
- Rear connector for other add-ons
- Microdrive compatible

Quickshot Joystick I £9.95

- Super positive response
- 2 fire buttons
- Stabilising suction caps
- 4ft lead

Quickshot Joystick II £12.95

- Incorporating all the features of 'Quickshot 1' plus
- Improved control grip
 - Trigger fire button
 - Rapid fire option



ONLY
£22.95

NEW!

It's Available NOW!

Please rush me the following

| | | |
|---------------------------------------|---------|-------|
| Programmable Joystick Interface | £ | _____ |
| Quickshot Joystick I | £ | _____ |
| Quickshot Joystick II | £ | _____ |
| Please add post and packing | £1.25 | |
| I enclose cheque/PO/Cash for | Total £ | _____ |
| or debit my Access/Barclaycard No. | | |

Signature _____ Name _____

Address _____

Or send S.A.E. for the New D.K.Trronics Spectrum Catalogue C7

"Available direct or from good computer shops anywhere"

dk'tronics

DK Tronics Ltd., Unit 6, Shire Hill Industrial Estate, Saffron Walden, Essex CB11 3AQ. Telephone: (0799) 26350 (24 hrs) 5 lines

The Spectrum Connection

THE FINAL TOUCH

We've just added the final touch to our professional keyboard. This new Microdrive compatible keyboard offers more key functions than any other in its price range. And the stepped keys and space bar make it even easier to use. Our keyboard, constructed from high density black ABS, will take your Spectrum into the professional league. It has 52 "stepped" keys plus space bar. A separate numeric key pad consisting of 12 red keys including a single entry 'delete' plus single entry 'decimal point', facilitate fast

numeric data entry. The 15" x 9" x 3" case will accommodate your Spectrum and other addons like interface 1, power supply etc. and forms an attractive self-contained unit. All connections, power, Mic, Ear, T.V., network RS232 and expansion port are accessible at the rear. A few minutes, a screwdriver and the simple instructions supplied are all you need to fit your Spectrum. All **dktronics** products are covered by a comprehensive guarantee.

Constructed from high density black ABS

All connections accessible at rear

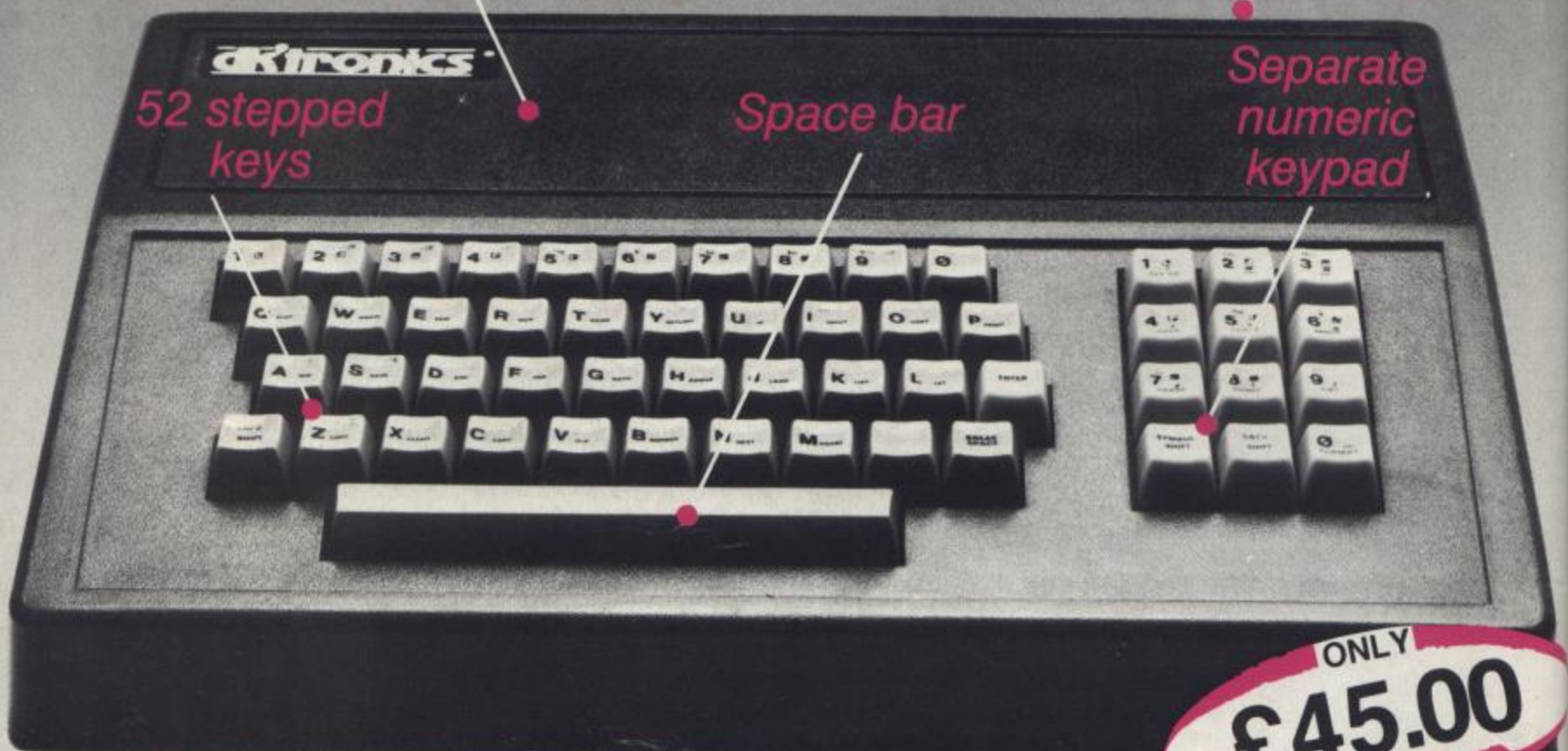

No Price Increases!

And it's Available NOW!

Please rush me the following

..... Microdrive compatible keyboard(s) £45.00

Please add post and packing £1.25

I enclose cheque/PO/Cash for Total £ _____

or debit my Access/Barclaycard No. _____

Signature _____ Name _____

Address _____

Or send S.A.E. direct for the new D.K.Trronics Spectrum Catalogue _____ C7

"Available direct or from good computer shops anywhere"

dktronics

DK Tronics Ltd., Unit 6, Shire Hill Industrial Estate, Saffron Walden, Essex CB11 3AQ. Telephone: (0799) 26350 (24 hrs) 5 lines

The Spectrum Connection

A STEP BEYOND.

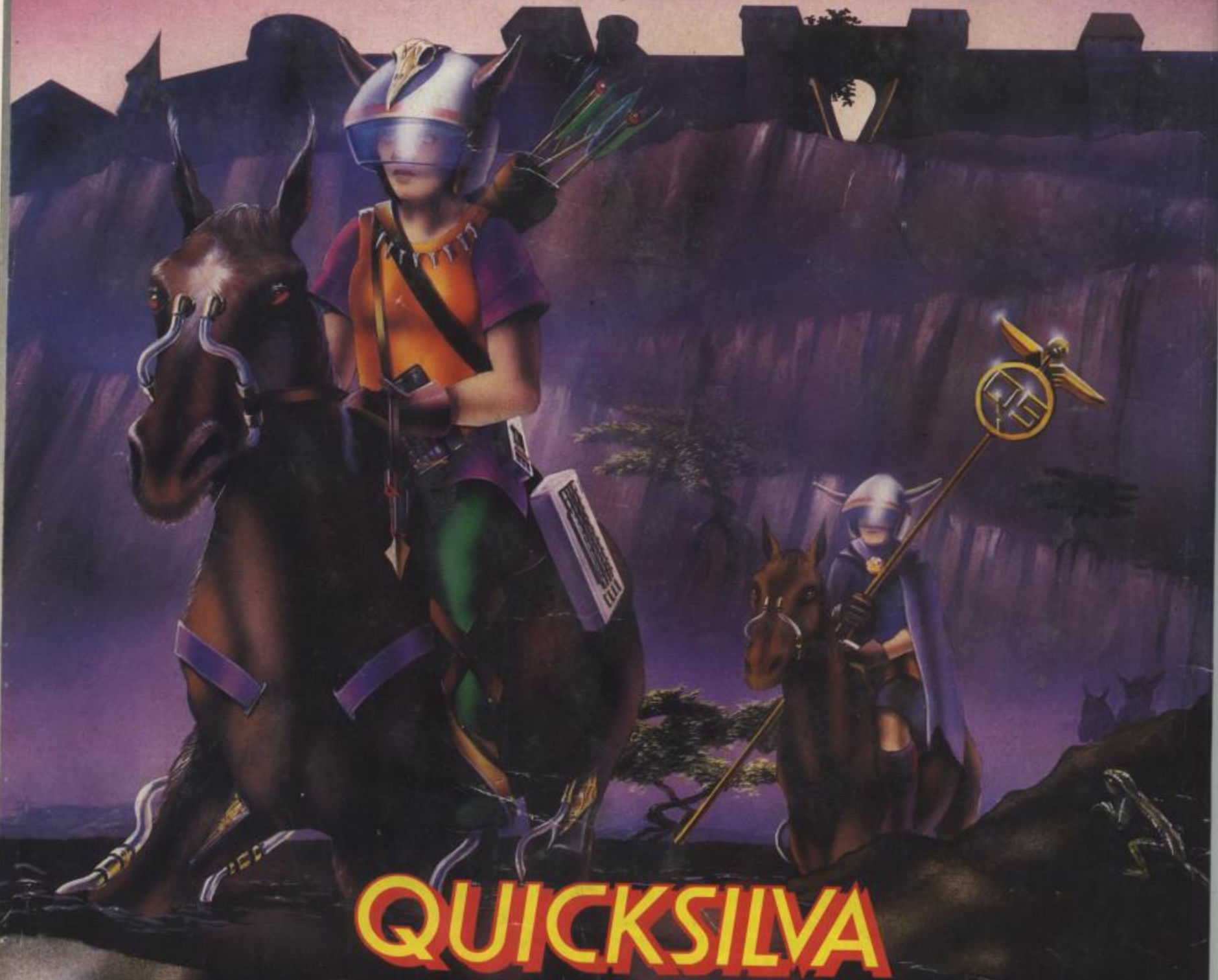

All Titles available mail order from:
 QUICKSILVA MAIL ORDER P.O. Box 6, Wimborne, Dorset BH21 7PY. Tel: (0202) 891744

FRED
 QUICKSILVA

 SPECTRUM 48K £6.95
 COMMODORE 64 £7.95

SNOWMAN
 The Snowman

 SPECTRUM 48K £6.95

BOOGABOO
 QUICKSILVA

 COMMODORE 64 £7.95
 SPECTRUM 48K £6.95

VELNOR'S LAIR
 QUICKSILVA

 ORIC/ATMOS £6.95
 SPECTRUM 48K £6.95

ANT ATTACK
 QUICKSILVA

 SPECTRUM 48K £6.95
 COMMODORE 64 £8.95

MINED OUT
 QUICKSILVA

 ELECTRON £6.95
 BBC £6.95
 LYNX £6.95
 SPECTRUM 48K £4.95
 ORIC/ATMOS £6.95

DRUMKIT

 BBC £9.95
 (IN A BOX + BOOKLET)

GATE CRASHER

 BBC/ELECTRON £6.95

NEW NEW GENERATION ON COMMODORE 64

TRASHMAN £7.95
 3D TUNNEL £7.95
 ESCAPE £7.95

NEW
 ELECTRO-ART
 ELECTRON £14.95

WARNING: These programs are sold according to QUICKSILVA Ltd's terms of trade and conditions of sale, copies of which are available on request.



Available at
WHSMITH



WOOLWORTH

John Menzies

and leading multiple retailers and specialist computer stores

NEW GAMES 48K SPECTRUM - AVAILABLE NOW
HAVE YOU JOINED THE GAME LORDS YET?
 and S.A.E. for details and